



FAN-SYSTEM INTERACTION AND BLOCKAGE EFFECTS FOR HVAC MULTI-FAN UNITS

F. Israel GUERRAS COLÓN, Sandra VELARDE-SUÁREZ, José GONZÁLEZ, Katia M. ARGÜELLES DÍAZ, Jesús M. FERNÁNDEZ ORO, Carlos SANTOLARIA MORROS

UNIVERSIDAD DE OVIEDO, Departamento de Energía, Edificio Departamental Este, Campus Universitario, 33203 Gijón, España

SUMMARY

A specific type of centrifugal fans named "squirrel-cage" is broadly used in parallel configurations within the evaporator unit of the HVAC systems for public transport. In these units, interaction effects arise, both between fans themselves and between fans and the structural elements. In this work, a study of different configurations allows to determine the minimum distances between the elements of the unit, in order to minimise these interaction effects and, as a consequence, the problems related to them. Furthermore, a study of the effect on the aerodynamic performance of a fan with different covering solutions is also carried out, confirming that any attempt to cover the engine area only intensifies this interaction effects and consequently the problems associated with it.

INTRODUCTION

Small fans, both axial and centrifugal, are often installed in the air conditioning systems for public transportation vehicles. In particular, small squirrel-cage fans are commonly used as part of the evaporator in air-conditioning systems. These fans are driven at relatively high speeds (around 4000 rpm might be reached), with extremely variable working conditions, probably far from the nominal ones. All these facts, together with the need to reduce fabrication costs, give rise to frequent instability problems, low performance, low efficiency and high levels of vibrations and noise.

In addition, when using multi-fan units, there are important geometrical restrictions which lead to interactions with the system. In the evaporator units of any of the aforementioned vehicles, it is common the use of parallel configurations of multi-fan units, which in modern designs, restrict the volume of air available around the fan. As a consequence of these closer locations, the units produce important interaction problems, detrimental of the overall efficiency of the system.

The main goal of this work is the optimization of a multi-fan unit, finding the minimum distance between fans to reduce the fan-system interaction effects up to reasonable limits. For such objective, an experimental set-up has been built and several experiments have been carried out. In particular, measurements to find the fan-wall interaction, the fan and two walls interaction and even

the interaction among three fans have been performed. The measurements were performed for two different flow rates, by regulating the opening valve in the conduct. While analysing the three fans working together, also the noise pressure levels were recorded using two microphones.

Through the analysis of the geometric characteristics for a wide range of fans used in HAVC systems, it was possible to find a significant trend in the industry to cover the engine located between the two fans in the machine for aesthetic reasons. A study of the effect on the aerodynamic performance of a fan with different covering solutions is also carried out.

NOMENCLATURE

b	=	impeller width (m)
BPF	=	blade passing frequency
\varnothing	=	Impeller outlet diameter (m)
d	=	distance (m)
f	=	frequency (Hz)
Lp	=	sound pressure level (dB)
P	=	pressure (Pa)
Q	=	flow rate (m ³ /h)

Greek Letters

Δ	=	increment
ω	=	angular velocity (rpm)
ρ	=	density (kg/m ³)
ψ	=	total pressure coefficient $\left(\frac{P_T}{\rho\omega^2\varnothing^2}\right)$
η	=	efficiency
Φ	=	flow rate coefficient $\left(\frac{Q}{\omega\varnothing^2b}\right)$
ζ	=	power consumption coefficient $\left(\frac{W}{\rho\omega^3\varnothing^4b}\right)$

Superscripts and Subscripts

eq	=	equivalent
T	=	total

MACHINE DESCRIPTION

The squirrel-cage fan studied in this article is a double impeller unit, arranged in a parallel configuration which is commonly used as part of the evaporator in air-conditioning systems for public transport (Figure 1). The fans in this unit blow the cooled air to the canalization which delivers the required flow rate to the passengers.

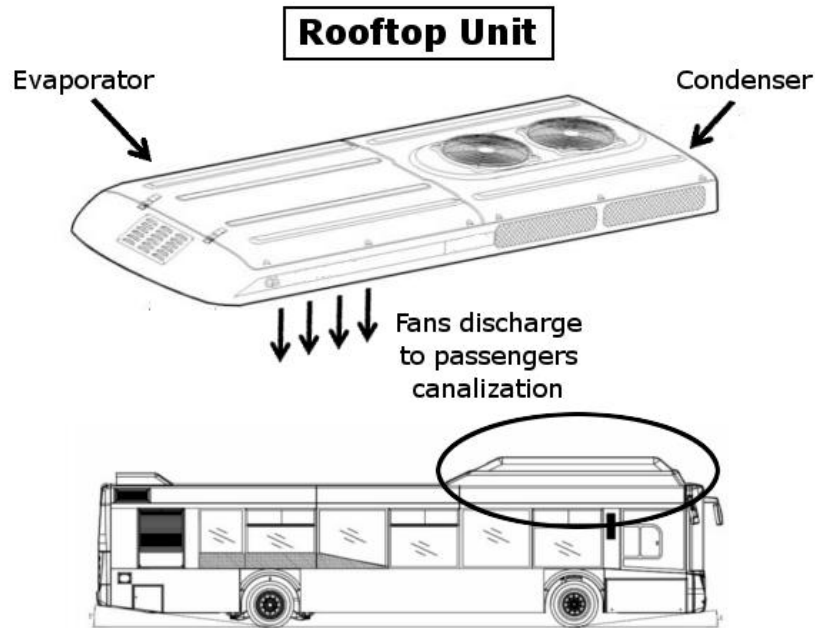

Figure 1: Rooftop unit of air-conditioning system

In Figure 2 a representation of the particular turbomachine can be seen. The two impellers are placed at both sides of the electrical motor and supported by the two sides of the shaft in cantilever. The shaft produces also the rotation of both impellers in a forward direction. Each impeller has two sets of short chord forward-curved blades separated by a central plate. Covering the whole unit, there is a volute or external casing, providing two rectangular outlet sections. The discharge sections are rectangular, while the aspirations are circular. Due to this configuration, these machines present two differenced inlets: two free inlets, one on each side of the fan, and two partially obstructed ones on the sides close to the electrical engine. All these facts lead to the appearance of non-symmetric inlet flow conditions.

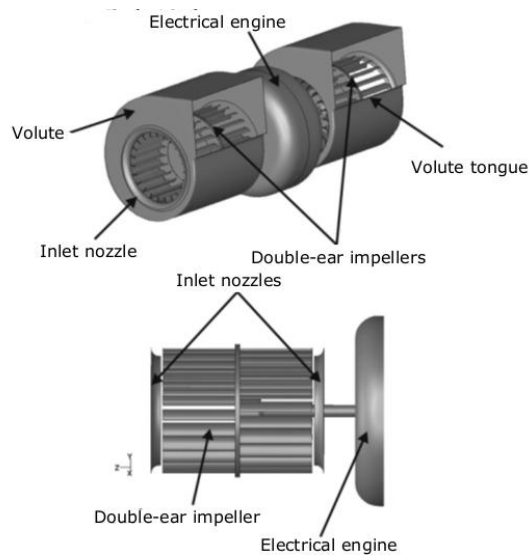

Figure 2: Squirrel-cage fan configuration

Note that the presence of the central plate is introduced to reduce the air recirculation at the inlet (Eck [1]). Moreover, it is a common practice to let the blades of each half lie half-way between those of its counterpart impeller, in order to minimize the noise component related to the tonal BPF.

METHODOLOGY

Two different studies are carried out. First, the interaction which takes place inside the evaporator unit is analysed. This means the interaction between the fans, as well as the one which occurs between the fan and the evaporator walls. The objective of these tests is to determine the minimum interaction distances between the different elements inside the evaporator unit. As a consequence, it could be possible to reduce the size of the unit by making better use of space, thus minimising production costs for the unit.

Second, the effects on the aerodynamic performance of the fan caused by different ways of covering the space between the two volutes, where the engine is located, is observed. Moreover, it is analysed how the evaporator gate affects the performance of the fan.

Fan-system interaction tests

For this study three configurations were tested. Two of them are shown in Figures 3 and 4. In these tests, a fan is running at maximum flow rate in a fixed structure. One or two wooden plates, depending on the tested configuration, are moved beside the free inlet perpendicularly to the rotation axis of the fan. In the test with two walls, they are moved simultaneously keeping the same distance between the wall and the free inlet at both sides. The tests were conducted at two different constant tensions for the electrical motor: 24 V and 26.5 V. These are typical values during the operation of the fans in the air-conditioning system. The rotational speed is chosen as an indicator. This is due to the linear relationship between the rotational speed and the flow rate when the fans are operated at constant tension (Figure 5), as in this case. For the fans used in this study, a 1% variation in the rotational speed implies a 5% decrease of the flow rate. During the tests, the rotational speed is constantly monitored, registering the variations that occur when the plate or plates get closer to the fan.

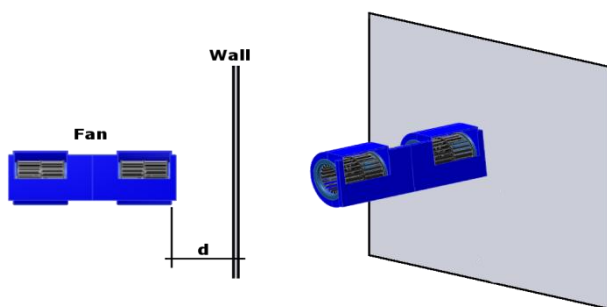

Figure 3: Fan – Wall testing sketch

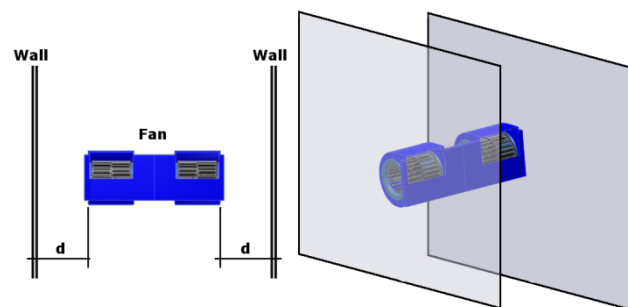

Figure 4: Wall – Fan – Wall testing sketch

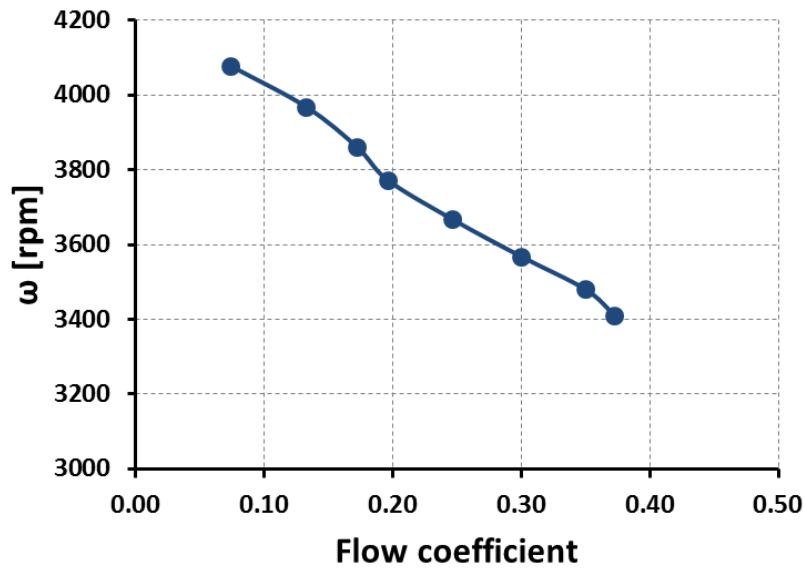

Figure 5: Rotation speed vs. Flow coefficient

In figure 6, the testing facility built to study of the interaction among three fans is shown. It consists of a wooden box with three inlets and an adjustable outlet. In the middle inlet there is a fixed fan, while mobile fans are placed in each of the side inlets. The output can be covered with a plate to simulate different operating conditions, including free inlet or obstructed cases. The use of a closed test bench in this case has two objectives. First, to simulate more accurately the real situation, including the system pressure losses. And secondly, to estimate the noise propagated to the ducts of the ventilation system. The tests are carried out with fans powered at 26.5 V. The “mobile” fans are moved to a new position, closer to the fixed fan, and the monitored rotational speed is recorded for each position.

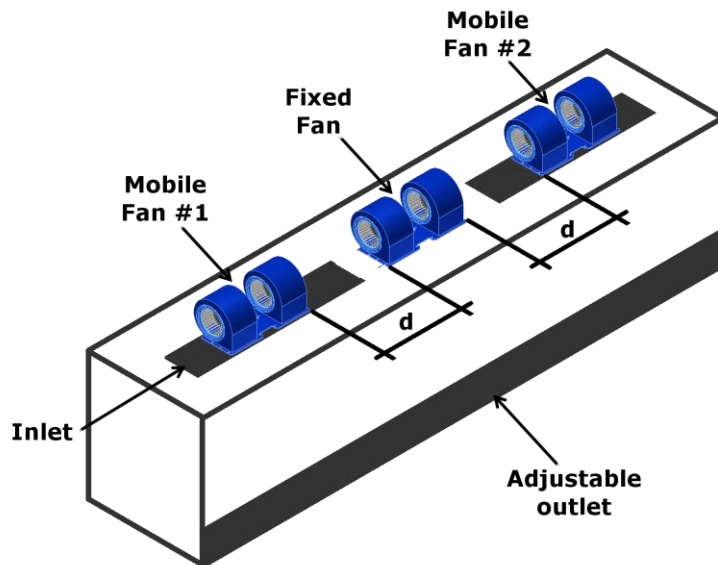

Figure 6: Fan – Fan – Fan testing facility sketch

At the same time the three fan interaction tests were carried out, the sound pressure levels were recorded using two 1/2” microphones. The signal from the microphone preamplifiers is introduced

in a 2-channel real-time acquisition unit, which software is afterwards employed to postprocess the measured signals. In the sketch of figure 7, the arrangement of the microphones inside the test bench is shown. One microphone is located at the symmetry plane, and the other is located 16 cm from the first one. The microphones are separated 15 cm from the projection of the rotational axis.

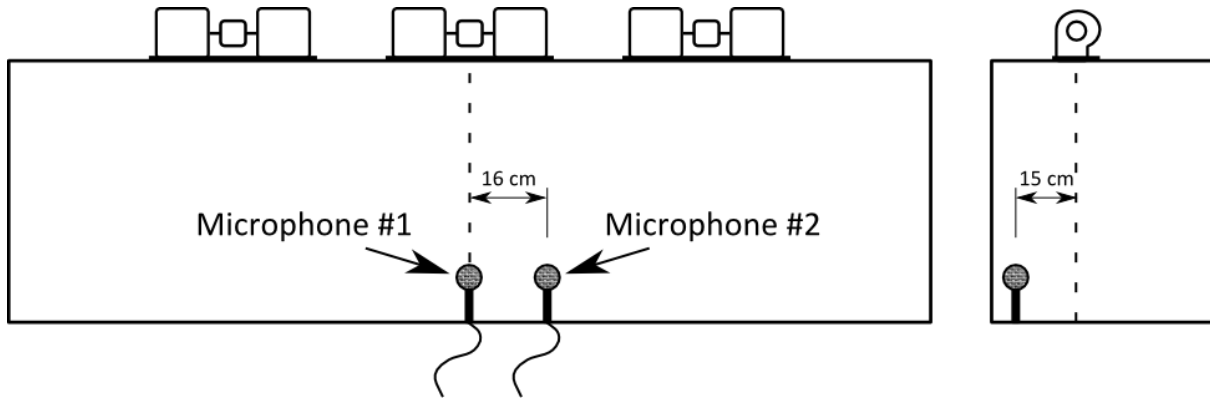

Figure 7: Microphones position in testing bench

Blockage effects tests

For the study of the blockage effects, an aerodynamic characterization of the fan and the different covering solutions have been made in a normalized ducted installation (type B according to ISO 5136 [2]). Figure 8 shows a drawing of this test installation. The flow leaving the two impellers is merged in a Y-shaped duct placed immediately downstream the outlet section. After leaving the fan, the air flows through a straightener in order to remove the swirl component generated by the fan. At the end of the facility, an anechoic termination removes undesired noise reflections and a regulation cone permits to modify the fan operating point.

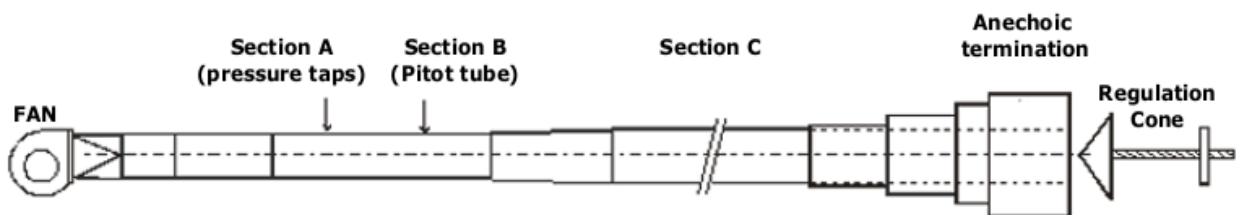

Figure 8: Sketch of the test installation

More details about the followed procedures can be found in Velarde-Suarez et al. [3]. The tests were conducted at a constant tension of 26.5 V for the electrical motor. The performance curves were obtained measuring between seven to eight points for the whole operating range of the fans, which was considered accurate to describe their overall characteristics. In each of these points, several data were collected: static pressure (Section A), dynamic pressure (Section B), electrical engine voltage and current intensity, rotation speed and acoustic pressure in the duct and in the aspirating region in the vicinity of the fan inlet. Air temperature and density in the laboratory were also recorded at the beginning of each fan characterization.

To recreate two different covering solutions (figures 9 and 10), the space between the volutes has been covered with a plastic sheet and some foam parts. Within each sheet, several slots and holes were made with different patterns.

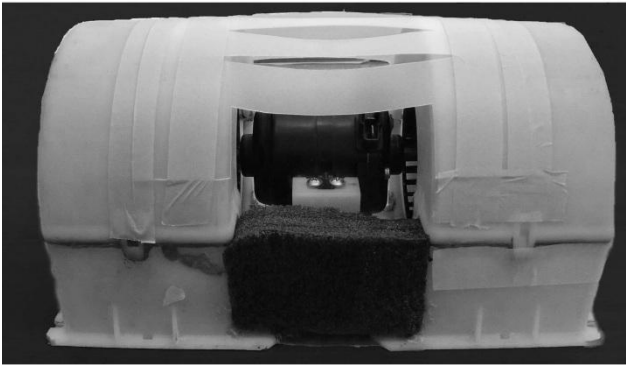

Figure 9: Fan covered with casing A

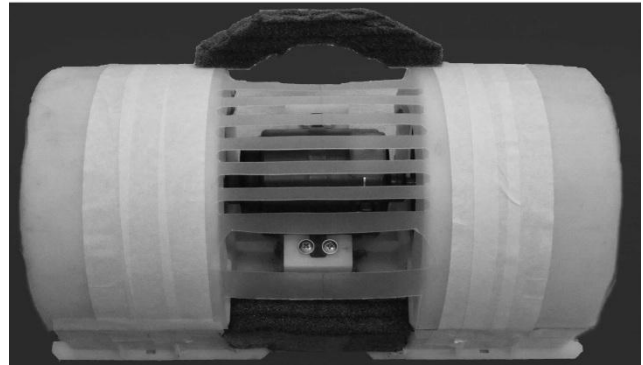

Figure 10: Fan covered with casing B

In order to study the effect of the evaporator gate, the fan was covered with a plastic sheet. Various foam blocks were used to maintain the distance between the plastic sheet and the fan. Figure 11 shows the fan connected to the test bench and the plastic sheet recreating the evaporator gate.



Figure 11: Evaporator gate simulation

RESULTS AND DISCUSSION

Fan-system interaction results

Figures 12 and 13 show the results obtained in the study of the interaction between the fan and a wall for the two tested operating conditions, 26.5 V and 24 V respectively. X-axis represents the distance between the wall and the free inlet (d) divided by the impeller outlet diameter (\varnothing). Y-axis shows the variation of the fan rotational speed. The speed variation is calculated respect to the first point, where no-interaction is assumed. As can be seen, the change in the trend of the curves occurs for values of d/\varnothing close to unity in both graphs.

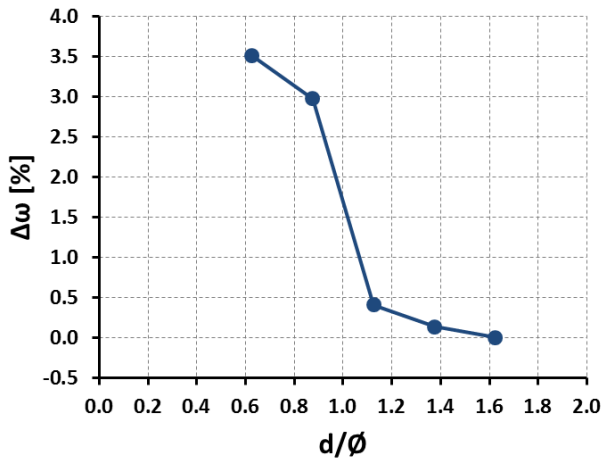

Figure 12: Interaction analysis of a Fan – Wall sketch.
 Tested at 26.5 V

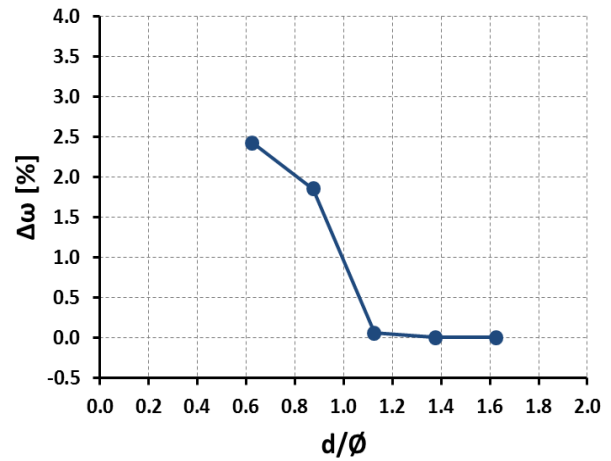

Figure 13: Interaction analysis of a Fan – Wall sketch.
 Tested at 24 V

For the interaction of the fan and two walls, the results are similar to the ones obtained in the previous case. As it is shown in figures 14 and 15, the variation in the rotational speed begins to be noticeable when the parameter d/\varnothing reaches values close to unity. Hence, for this value and lower ones, the flow rate loss due to interaction effects is considered significant.

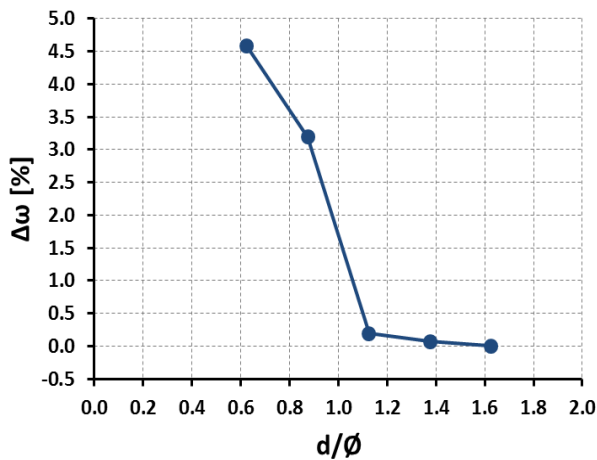

Figure 14: Interaction analysis of a Wall – Fan – Wall sketch.
 Tested at 26.5 V

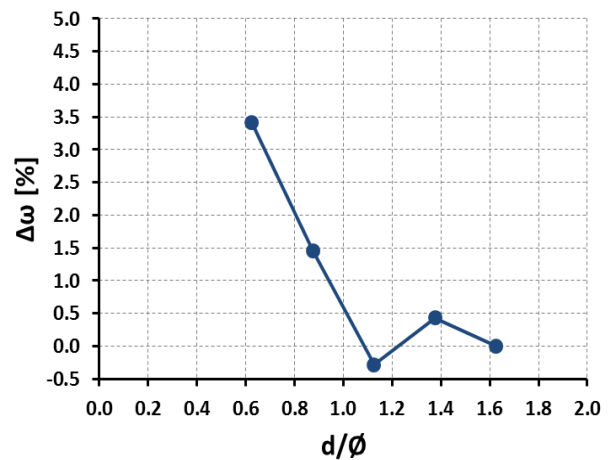

Figure 15: Interaction analysis of a Wall – Fan – Wall sketch.
 Tested at 24 V

The results obtained for the three fans interaction test are shown in figures 16 and 17. X-axis represents the distance between the free inlets of the fixed and mobile fans (d) divided by the impeller outlet diameter (\varnothing), while Y-axis represents the variation of the fan rotational speed measured respect to the first point of the series. Both for the free outlet test and for the one carried out with the partially obstructed outlet, the change in the rotation speed, and thus the flow rate fall, take place for values of d/\varnothing around 1.6.

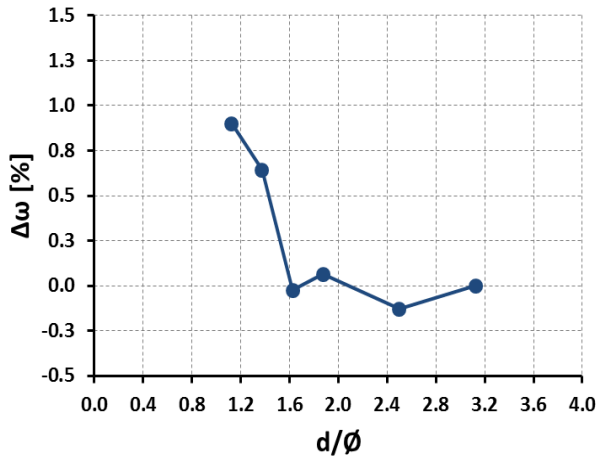

Figure 16: Interaction analysis of a Fan – Fan – Fan sketch. Tested with free outlet

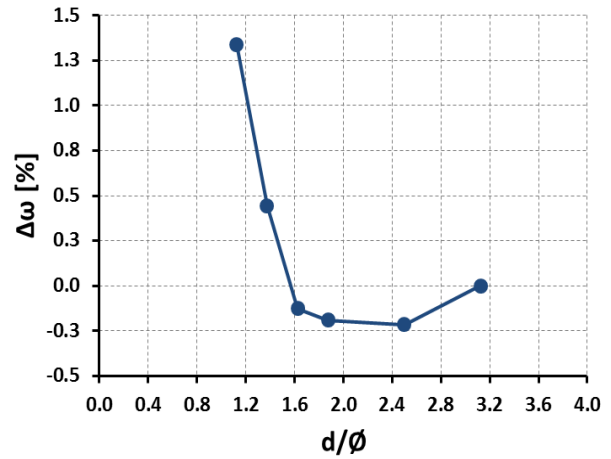

Figure 17: Interaction analysis of a Fan – Fan – Fan sketch. Tested with partially obstructed outlet

Additionally, in the course of the interaction test, the sound pressure spectrums as well as the equivalent continuous sound pressure levels ($L_{p_{eq}}$) were recorded by both microphones. This last parameter is plotted against the dimensionless distance (d/\varnothing) in figures 18 and 19. A quite constant trend can be seen for both microphones, independently of the conducted test. The $L_{p_{eq}}$ levels obtained during all the tests carried out values around 90-92 dBA. These values are slightly lower than those obtained in the aerodynamic and acoustic characterization of one of the fans used, which reach 92-95 dB for the entire operating range.

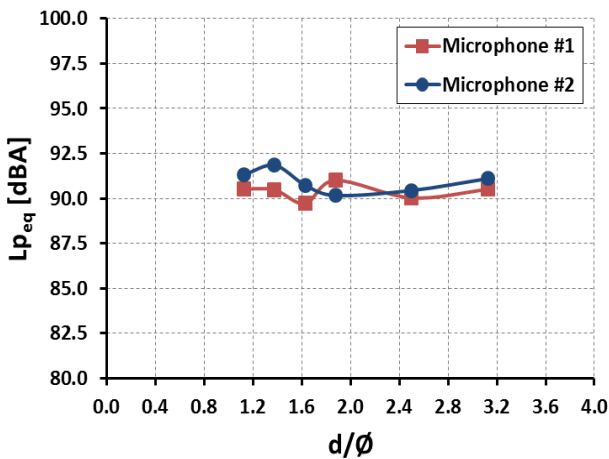

Figure 18: Noise analysis of a Fan – Fan – Fan sketch. Tested with free outlet

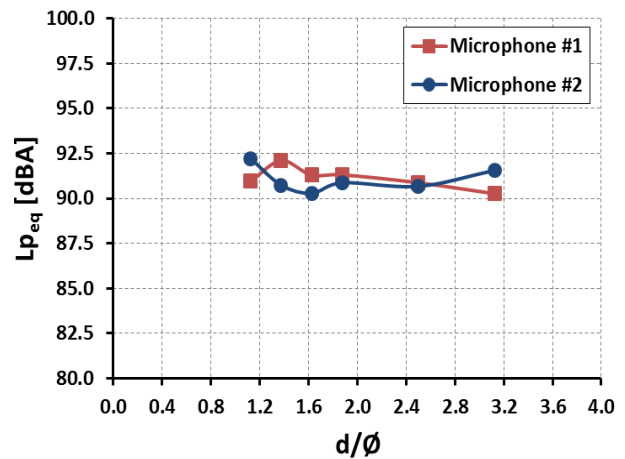

Figure 19: Noise analysis of a Fan – Fan – Fan sketch. Tested with partially obstructed outlet

Analysing the frequency response obtained, more information about the behaviour of the fans was retrieved. In an aeroacoustic study on a small squirrel-cage fan for public transport made by Velarde-Suárez et al. [4], it was found that the predominant tonal component in the noise generation of this fan is the blade passing frequency one. It was noticed that the relevant values of the blade passing levels in these cases could be explained by the high pressure fluctuation values found, not only close to the volute tongue, but also in the rest of the volute. This fact is probably due to the size restrictions commonly suffered by these devices, which constitute a clear limitation on the volute design. In figure 20, the L_p spectrum for the microphone #1 is plotted. Box A indicates the area corresponding to the frequency range where the BPF is located. This spectrum was obtained

during the free outlet test and a relative distance between fans d/\varnothing of 1.6. Several peaks can be clearly identified, three in total, each one belonging to each of the fans. Some of these peaks are not well defined, indicating the irregular or unstable behaviour of these fans. The peak value at the BPF lies between 73-78 dB in this test.

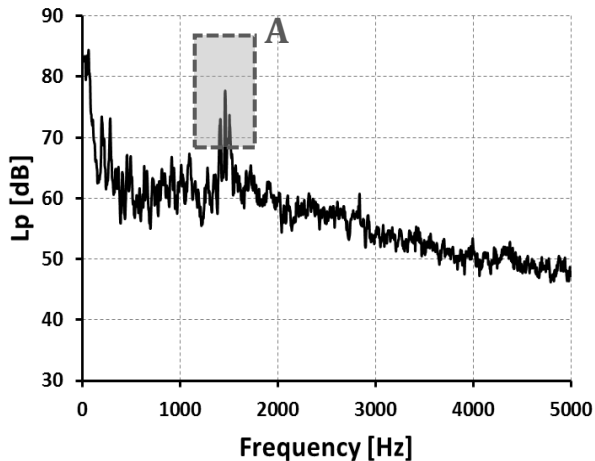

Figure 20: L_p spectrum of microphone #1.
Free outlet test with $d/\varnothing=1.6$

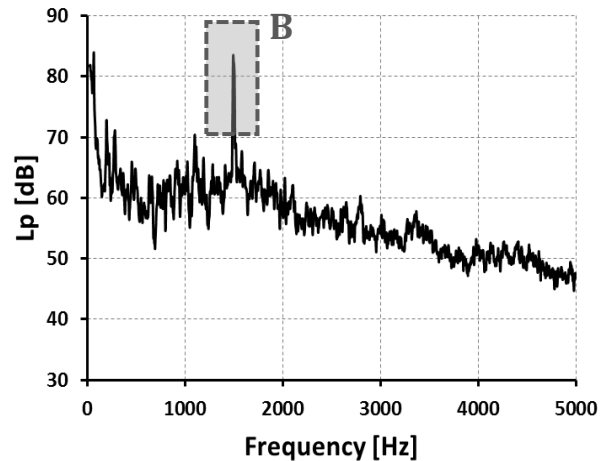

Figure 21: L_p spectrum of microphone #1.
Partially obstructed outlet test with $d/\varnothing=1.1$

In a different test, as shown in figure 21, instead of three peaks, a single peak with high sound pressure levels is noted (box B). In this case, the test in question corresponds with the one carried out with the partially obstructed outlet and a distance between fans (d/\varnothing) of 1.1. The L_p measured peak value is above 80 dB.

The sound frequency analysis shows the instability in the working conditions of the fan. Sometimes the fans in the unit are working at different operating conditions, and hence the appearance of three peaks at the blade passing frequency. However, it may happen that the three fans are rotating at the same speed, which causes the appearance of a single peak at the blade passing frequency. Furthermore, this single peak has a value much higher, about 6 dB, due to the sum of the noise levels of each of the fans.

Blockage effects results

In figures 22 and 23, performance curves for the three analysed covering solutions are shown. All the configurations studied, without “engine-casing” and both covering solutions, present the typical performance curves associated to forward-curved blades centrifugal fans, including instability zones. In the central flow zone, a loss of pressure followed by a recovery can be noticed in all these cases. This instability, denoted by a flat or positive slope in the performance curve, is inherent to the design of this type of forward-curved blade fans. The authors, in previous experiences, observed an increment of unstable effects with increasing rotational speed. Thus, this unstable behaviour seems to be intensified by the poor structural stiffness of the impeller blades. At first sight, the effects of the casing can be appreciated. There is a considerable loss of total pressure respect to the one shown by the fan without engine-casing. As pointed before, these fans work under varying operating conditions in the evaporator in air-conditioning systems. Hence, a total pressure reduction, which is accompanied by a reduction in flow, may influence the design of the unit. A lower flow rate means that more fans may be needed to fulfil the requirements of the facility. Another consequence is the accentuation of the flow asymmetry. As mentioned before, due to the specific machine configuration consisting in an engine between two volutes, the inlets close to the engine are partially obstructed. So, covering the engine will only intensify this effect.

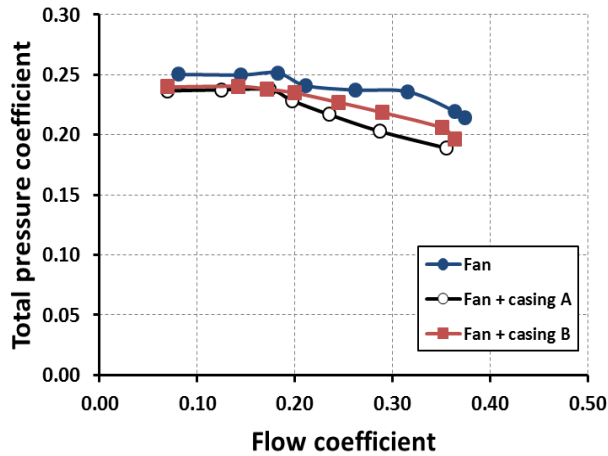

Figure 22: Total pressure coefficient vs. Flow coefficient. Covering solutions tests

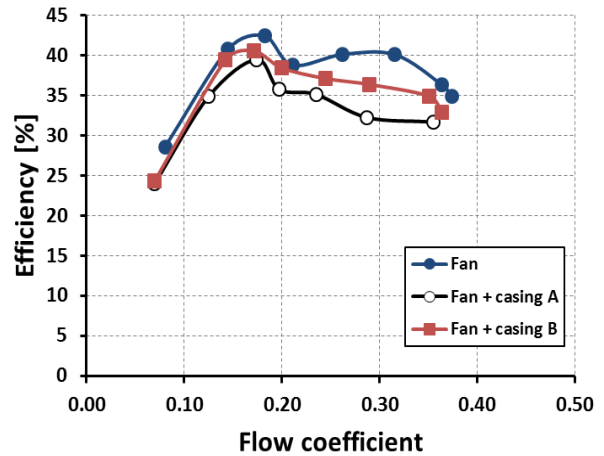

Figure 23: Efficiency vs. Flow coefficient. Covering solutions test

In the evaporator gate tests, something similar occurs. The performance curves obtained in these tests are shown in figures 24 and 25. As can be seen, the evaporator gate causes a loss of total pressure, which results in efficiency decrease of the fan.

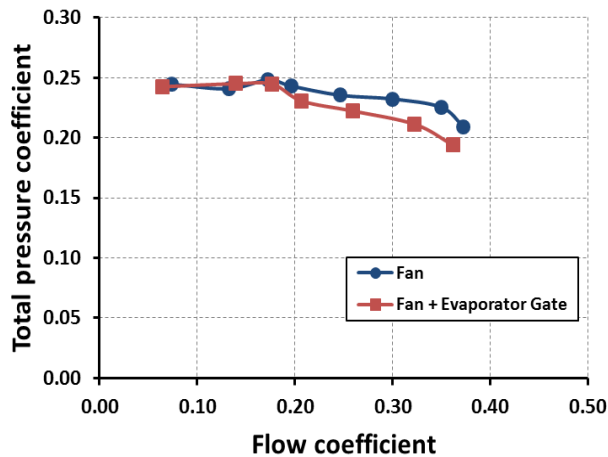

Figure 24: Total pressure coefficient vs. Flow coefficient. Evaporator gate test

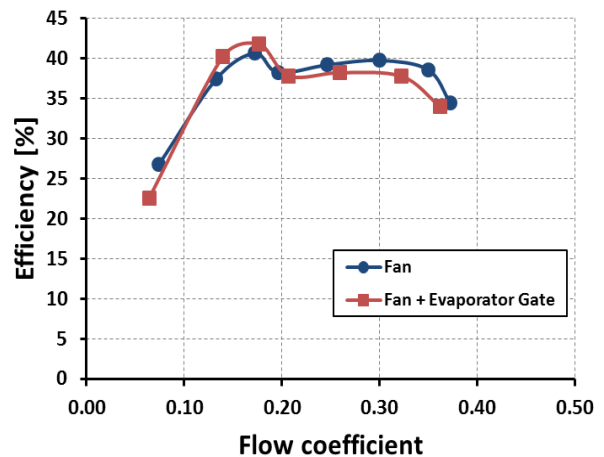

Figure 25: Efficiency vs. Flow coefficient. Evaporator gate test

Conclusions

In this paper, a study of the interaction effects of the fans within the evaporation system in HVAC applications in public transport was conducted. Different conclusions have been obtained in this study. Firstly, the minimum distance between any fan and a solid wall for a given rotational speed is one diameter. Secondly, for a multi-fan installation, the results show a limit around 1.6 diameters as minimum distance between two fans.

The recorded sound pressure levels were found almost independent of the fans distance. The sound frequency analysis shows the instability in the working conditions of the fan. Sometimes several peaks are observed for the blade passing frequency range, and sometimes a much higher peak appears with a relatively wide bandwidth and high noise levels. In real conditions, in the vehicle, there may appear situations where the inconveniences for the passengers increase without changing the system operating conditions.

Another analysed aspect is the blockage effects caused by covering the space occupied by the engine between the two volutes of the machine. It is well known that the engine causes a blocking effect in the aspirations closer to it, which implies asymmetric flow and other problems. The results show that any attempt to cover the engine area only intensifies this effect and consequently the problems associated with it.

Finally, the effect of the evaporator gate on the fan performance was studied. Due to the attempt to minimize the dimensions of the evaporator unit, when the door is closed, it leaves a very small gap between it and the fan. This causes in some way a blockage of the inlets, having a negative impact on the fan performance. An important consequence of the blockage effects is the total pressure loss. The flow rate also decreases, which can lead to the need of installing more fans to fulfil the requirements of the system. Although the dimensions of the HVAC units are determined by many factors: weight, vehicle aerodynamics, materials costs, etc., it is noted that the lack of space around the fan has a noticeable effect on the unit performance.

ACKNOWLEDGMENTS

The authors acknowledge the support from the “Ministerio de Ciencia e Innovación” under Project “Tecnologías ecológicas para el transporte Urbano, ecoTRANS” (CDTI).

The authors also gratefully acknowledge the collaboration and the kind permission for publication of Hispacold International S.A., with a special mention to D. Juan Bernal-Cantón, from the Department of Innovation.



BIBLIOGRAPHY

- [1] Eck, B., – *Fans, Design and operation of centrifugal, axial-flow and cross-flow fans*, Pergamon Press Ltd. **1973**
- [2] *International Organization for Standardization ISO 5136:1990 and Technical Corrigendum 1:1993. Determination of sound power radiated into a duct by fans. In-duct method.* **1990**
- [3] Velarde-Suárez S, Ballesteros-Tajadura R., Pereiras-García, B., Santolaria-Morros, C., – *Reduction of the aerodynamic tonal noise of a forward-curved centrifugal fan by modification of the volute tongue geometry*, Applied Acoustics, Vol. 69, pp. 225–232. **2008**
- [4] Velarde-Suárez S, Ballesteros-Tajadura R, González, J., Pereiras-García, B., – *Relationship between volute pressure fluctuation pattern and tonal noise generation in a squirrel-cage fan*, Applied Acoustics, Vol. 70, No. 11-12. , pp. 1384-1392. **2009**