

## Energy from closed mines: Underground energy storage and geothermal applications



Javier Menéndez<sup>a,\*</sup>, Almudena Ordóñez<sup>b</sup>, Rodrigo Álvarez<sup>b</sup>, Jorge Loredó<sup>b</sup>

<sup>a</sup> Hunaser Energy, Avda. Galicia, 44, 33005, Oviedo, Spain

<sup>b</sup> Dep. Mining Exploitation and Prospecting, University of Oviedo, Independencia 13, 33004, Oviedo, Spain

### ARTICLE INFO

#### Keywords:

Energy storage  
Underground pumped-storage  
Compressed air storage  
Geothermal use  
Mine water  
Mining reservoir  
Renewable energy

### ABSTRACT

In the current energy transition, there is a growing global market for innovative ways to generate clean energy. Storage technologies are potential and flexible solutions to deal with the intermittent nature of renewable resources. Closed mines can be used for the implementation of plants of energy generation with low environmental impact. This paper explores the use of abandoned mines for Underground Pumped Hydroelectric Energy Storage (UPHES), Compressed Air Energy Storage (CAES) plants and geothermal applications. A case study is presented in which the three uses are combined in just one mine. This preliminary study allows estimating an electrical energy generation of 153 and 197 GWh year<sup>-1</sup> at the UPHES and CAES systems, respectively, and a thermal energy generation of 0.41 GWh year<sup>-1</sup> at the geothermal system, with a total cost of 358 M€. An underground closed mine can be used to store energy for re-use and also for geothermal energy generation, providing competitive renewable energy with a low CO<sub>2</sub> footprint. These initiatives aid to ensure sustainable economic development of communities after mine closure.

### 1. Introduction

Global energy demand is set to grow by more than a quarter to 2040 and the share of generation from renewables will rise from 25% today to around 40% [1]. This is expected to be achieved by promoting the accelerated development of clean and low carbon renewable energy sources and improving energy efficiency, as it is stated in the recent Directive (EU) 2018/2002 on energy efficiency. The European Commission has pledged a 27% share of renewable energy production as a target for 2030 [2]. Around 17% of primary energy consumed in Spain comes from renewable sources, mainly hydroelectric and wind, by means of facilities of the past decade [3]. Large scale implementation of renewable capacity can result in irregularities in electricity supply produced by sudden changes in wind speed or solar irradiance, so flexible generating capacity technologies are demanded [4,5]. According to the Paris Climate Agreement, all electricity generation should be decarbonized by 2050; since investments in this sector are usually carried out with a 20–25 year planning, there is no time to lose.

The role of mining is significant in the current globalized economy, hungry of resources, so pioneering and sustainable post-mining technologies to reduce environmental impacts and generate new resources (clean energy and water) will be demanded. The extraction of mineral resources from underground deposits require shafts and extensive

galleries to access the mineralized areas. After mining, these voids (which were usually partially waste filled) are usually left to be flooded, but often perpetual costs related to pumping to keep a safe water level or water treatment have to be maintained, becoming long-term liabilities. The recharge water frequently needs to be pumped to the surface and treated at significant cost, constituting a large economic burden on current and future generations. Innovative technologies for sustainable post-mining solutions include the geothermal use of mine water and the pumped energy storage using the mine infrastructure, taking advantage of the deep mine shafts and voids, and the pumping installations.

Worldwide, the estimate of the number of abandoned mines exceeds one million [6]. Fig. 1 shows the main coal mining areas and salt deposits in Europe. Lignite is predominantly mined in open pits while hard coal mines include both surface and underground operations. Salt caverns are widely used for natural gas storage and currently in Europe there are over 141 storage facilities accounting for over 98,168 Mm<sup>3</sup> of natural gas storage [7]. Underground energy storage and geothermal applications are applicable to closed underground mines. Usually, UPHES and geothermal applications are proposed at closed coal mines, and CAES plants also are analyzed in abandoned salt mines. Geothermal power plants require flooded mines, which generally have closed more than 5 years ago. Conversely, UPHES and CAES plants should be

\* Corresponding author.

E-mail address: [jmenendezr@hunaser-energia.es](mailto:jmenendezr@hunaser-energia.es) (J. Menéndez).

<https://doi.org/10.1016/j.rser.2019.04.007>

Received 23 December 2018; Received in revised form 13 March 2019; Accepted 2 April 2019

Available online 10 April 2019

1364-0321/ © 2019 Elsevier Ltd. All rights reserved.

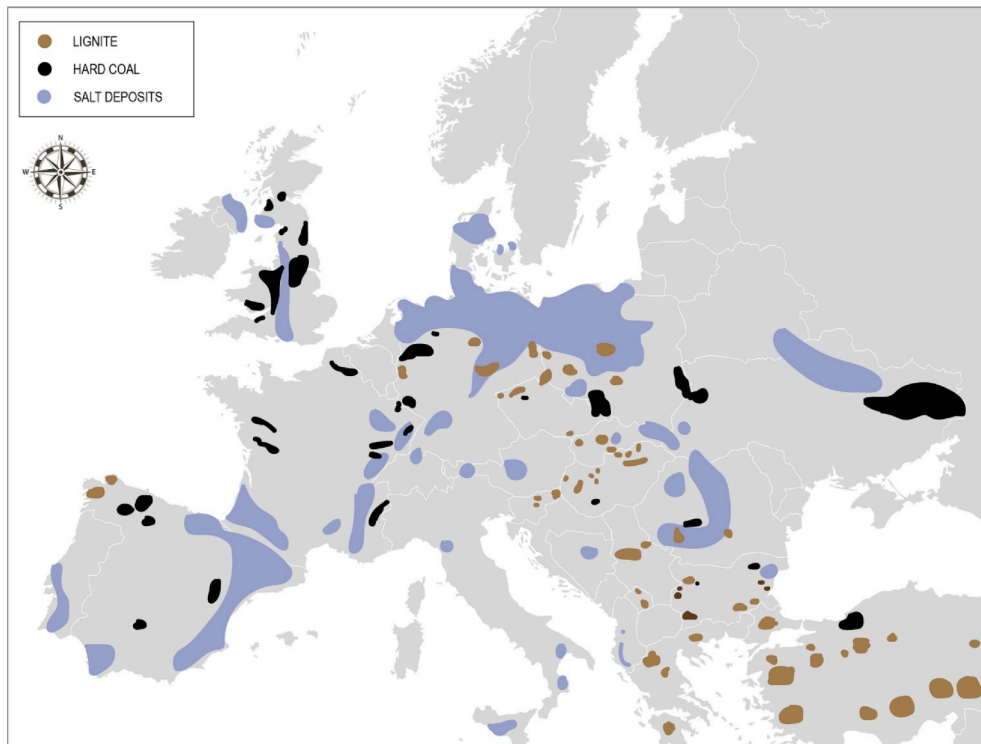

Fig. 1. Location of main coal mining areas and salt deposits in EU [13,30].

installed in mines which are not completely flooded. Mountain mines are not considered for these purposes. Besides, some mines are adapted to become museums and/or educational centers.

It has been estimated that 3000 MWt of heat energy is available in the waters of flooded coalfields of Europe [8]. In Germany, about 160 mines in the Ruhr area exploited more than 150 million tons of coal, but the last two mines in Bottrop (Prosper Haniel mine) and Ibbenbüren closed in 2018 [9]. The deepest coal pits in Germany reach depths of up to 1800 m [10]. Although depths above 1300 m are reached in the Ruhr area (e.g. in Zeche Prosper-Haniel [11]), the majority of the coal mines are 500–1000 m deep. Regarding other EU countries, in Poland there are several active underground coal mines, in Spain there is only one active underground coal mine and in France, the last coal mine closed in 2004. Table 1 shows the main potential underground mines in UE valid for energy storage and geothermal applications.

Pumped storage power plants and compressed air energy storage plants have been in use for more than a hundred and forty years, respectively, to balance fluctuating electricity loads and to cover peak loads helping to meet the growing demand for sustainable energy, with high flexibility. The system increases revenues by selling electricity during periods of higher demand, when electricity prices are highest, and they allow to store intermittently provided energy, such as solar or wind, which have a continuous growth. Those systems designed using

mine (infra)structures are particularly advantageous, provided that certain requirements, such as sufficient storage capacity and stability, are met. On the other hand, the use of abandoned mines for geothermal heat recovery by means of heat pumps constitute a versatile and practical alternative for the heating and cooling of buildings, having a low CO<sub>2</sub> footprint.

In this paper, the literature on underground energy storage using closed mines, as well as that for the geothermal use of mine water is reviewed. Finally, the theory is applied to a coal mine in NW Spain, as a case study.

## 2. Hydroelectric energy storage

### 2.1. Pumped Hydroelectric Energy Storage (PHES)

A classical pumped-storage plant is established between an upper reservoir and a lower reservoir (or e.g. a river) connected by a driving line and a pump-turbine unit. During off-peak times (at night) the water is pumped from the lower reservoir to the upper reservoir using electrical energy from the grid, and during peak demand times (at some hours during the day), the water flows back into the lower reservoir through turbines to produce electricity which is fed back into the grid [31]. The plant is a net consumer of energy, due to the losses of the

Table 1

Potential underground mines in EU for energy storage and geothermal applications, according to published data.

Country	Number of mines	State	Depth range (m)	Water outflow (Mm <sup>3</sup> year <sup>-1</sup> )	References
France	81	Flooded	500-1200	120	[12,14–19]
Germany	23	Flooded	200-1800	48-54 <sup>a</sup>	[12,13,20–22]
	4	Non-Flooded	200-1300		
Poland	28	Active	300–800	209	[12,13,23–25]
	26	Flooded	300–800		
Spain	36	Flooded	200–700	37	[12,13,57,82]
	12	Non-Flooded	300–600		
UK	64	Flooded	300-1200	N/A	[12,13,26–29]

<sup>a</sup> Ruhr Area.

pumping, friction, etc.; the energy storage efficiency (quotient between the energy supplied and the energy taken from the grid) is usually in the 70–80% range [31–35]. However, the profit of this scheme lies on the price difference between the consumed low-cost surplus off-peak electricity and the generated peak electricity, which is sold for a higher price, and this tariff difference is expected to last in the medium term. Leaving aside other costs, if the efficiency is e.g. 70%, the energy selling price must be 1.4 times higher than the off-peak price, for the system to be economical. Pumped storage power plants store electricity in the form of potential energy of the water, when it is pumped from a lower to a higher elevation and this potential energy can be converted back into electricity during demand peaks. The storage capacity is related to the height difference and the volume of stored water [36]. These systems complement net-energy producing systems, since they allow saving excess energy from continuous base-load sources, such as coal, gas, oil or nuclear and from fluctuating or intermittent sources, such as wind, tidal or solar power [34]. Pumped storage is the largest-capacity form of large-scale energy storage available, which is essential for ensuring grid stability and supply security when conventional fuel is replaced by renewable energy sources [32,37] and to cover peak load demand in an unstable energy environment [38]. In addition, the response time of the Pumped Hydroelectric Energy Storage (PHES) to deliver energy to the grid is very short compared to conventional power plants. Chen et al. [39] estimate that above 70% of the excess energy generated by conventional plants can be reused via PHES plants, and now they account for 99% of bulk storage capacity worldwide, around 180 GW [34,40]. Extensive energy storage technology reviews are provided in Refs. [41–46], in addition to other references already mentioned in this section.

## 2.2. Underground Pumped Hydroelectric Energy Storage (UPHES)

A further expansion of surface pumped storage power plants is limited by their topographic requirements (available elevation difference between the both reservoirs) and by their public acceptance in relation to the land use and the associated environmental impact [36]. In that sense, these systems can be designed so that the lower reservoir (and even the upper reservoir) are underground (UPHES). This concept was firstly proposed by Fessenden in 1910 [47]. The advantage is not economic but the installations are not visible and there is no need to construct dams occupying scenic mountain areas [38]. In addition, the lower reservoir can be placed directly under the upper one, so the horizontal distance between the reservoirs the length of the water conduits are minimized [48]. The head difference is usually higher than in PHES systems, so smaller reservoirs can generate the same amount of energy [49]. Interesting discussions about UPHES can be found at [50–52]. Although the lower reservoir can be drilled, underground or open pit mines can be used for that purpose [53–55], being proposed by Harza in 1960 for the first time [56].

The capacity  $P$  (W) of a pumped-storage plant can be obtained from the general equation:

$$P = \rho \cdot g \cdot Q \cdot H \cdot \eta \quad (1)$$

where  $\rho$  is the density of water ( $1000 \text{ kg m}^{-3}$ ),  $g$  is the acceleration due to gravity ( $9.81 \text{ m s}^{-2}$ ),  $Q$  is the discharge through the turbine ( $\text{m}^3 \text{ s}^{-1}$ ),  $H$  is the net hydraulic head, discounting the head loss ( $\text{mH}_2\text{O}$ ), and  $\eta$  is the efficiency of turbine and generator, which is usually around 90%. The size of the smallest reservoir controls the duration that the discharge can be maintained, and the energy delivered per cycle [48]. Since  $Q$  is the relation between the water volume (water storage capacity of the smallest reservoir) and the time (operational hours), the storable amount of energy, in MWh, depends only on the water storage capacity and the net hydraulic head,  $H$  (Fig. 2a). Fig. 2b shows the output power of the Francis turbine, considering a cycle time at full load of 4 h.

## 2.3. UPHES plants using mine structures

Hydroelectric energy can be produced and stored using inactive underground mines, so that the pumped storage is established between a reservoir set on the surface or in the upper levels of the mine and a lower reservoir in deeper parts of the mine by the use of the mine shaft equipped with turbines. The main components can be located underground (both reservoirs, the cavern containing the hydroelectric energy generator, the electric supply lines and the return lines connecting to the grid), but a hybrid system, whose upper reservoir is at the surface, is preferred. This variant is more effective, since it has a greater storage capacity, due to a higher height difference between reservoirs, and the cost associated to the underground work is reduced, too [36].

These UPHES systems provide additional advantages: the voids are already excavated, the mineshaft is ready to access the mine levels, where other tunnels can be excavated if necessary, and the mine has its own underground pumping infrastructure (pumps, pump chambers connected to the grid, pipes and dams that could be used by a UPHES). Also, if the continuous ingress of infiltrated water is balanced by corresponding discharges, the abandoned mine voids are kept dry and accessible, preventing them from being flooded with water that may end up being polluted and in need of treatment [38,57]. Even when the pumping has to be maintained, the associated costs can be compensated by the energy generation. Most UPHES are designed to be operated as closed water loops, but open systems are also possible: using an aquifer as lower reservoir or allowing that natural recharge feeds the system while surplus water is pumped back to the surface, so mine flooding is prevented, as well as water contamination [38]. Moreover, the proposed systems can be combined renewable energy storage, such as wind and solar power and with geothermal energy exploitation, taking advantage of the temperature of the deep mine water and also they can be combined with a system of mine water use as a water resource, for drinking supply, agricultural or industrial use.

Not every mine is suitable for this application. Exhausted mines are preferable to those that house still mineable deposits. Moreover, stability is a decisive factor, so that mines where dissolution processes can occur (such as evaporite deposits), or those where explosive gasses or toxic substances could be released, should be avoided [36,58]. Recently closed mines are preferable to the old ones, because in the former the morphology of the mine is better known. Even those mines that have been sealed can be retrofit, resuming the pumping and restoring the shaft, from which the necessary cavities are excavated. Furthermore, it is desirable that the selected mines are located in populated areas, so there are close energy end-users, which could benefit from the system. On the other side, old mine infrastructure is often preserved as industrial-historical heritage, and this might difficult its use for a UPHES.

The mine voids (galleries, porosity left after mineral extraction, etc.) could serve as lower reservoir of the UPHES, but the geological-geomechanical characteristics of the enclosing rocks, as well as the operating conditions (e.g. pressure variations) must be analyzed thoroughly, because they can compromise the stability of the underground openings [58]. This is particularly the case of the workings in the upper levels, where the oldest infrastructure in the mines is located. Thus, drilling a new network of tunnels postulates as the most technically feasible alternative for the lower reservoir [57,59]. Bodeux et al. [53] and Pujades et al. [49] model the influence of the UPHES to groundwater flow due to the oscillation of the water level. Menéndez et al. [60] model different designs of the tunnel network constituting the reservoir to analyze their behavior.

Although there are not many examples of UPHES using mine structures and there are still no full-scale systems in operation, some technical and feasibility studies have been published. The recently closed Prosper-Haniel hard coal mine in North-Rhine Westphalia (Germany) is set to turn into a 200 MW UPHES plant. In this project, 1 million  $\text{m}^3$  of water will be allowed to plunge 1200 m, turning turbines at the bottom of the colliery's mine shaft, meaning a storage capacity of

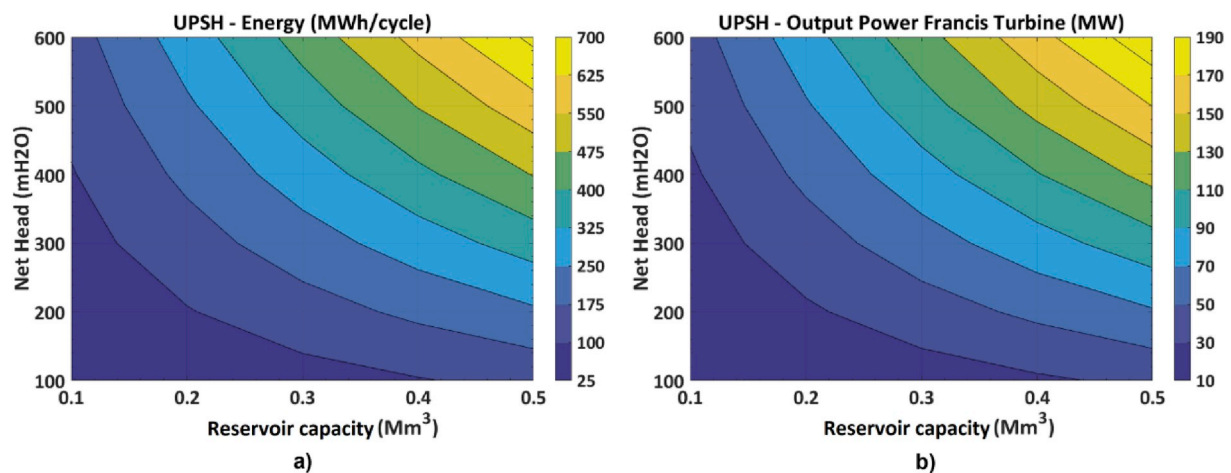

Fig. 2. a) Energy storage per cycle of an UPHEs as a function of water storage and net head, considering an efficiency of 90, 98.5 and 99% for the turbine, the alternator and the transformer, respectively; b) Power generated considering a cycle time at full load of 4 h.

3 GWh [61], although other sources give much conservative values for realistic scenarios of use [62]. In the case of Germany, a theoretical total output of 10 GW and a storage capacity of 40 GWh in the suitable mine structures, are estimated [36]. The additional advantages found when these systems are applied to the deep and stable South African gold mines, such as preventing mine water treatment, were studied by Winde et al. [38], who provide a comprehensive and interesting study about the applicability of mines for UPHEs. The same publication mentions previous encouraging surveys conducted by the main electricity provider company in South Africa to explore potential high head underground pumped storage in mines, which was ultimately not performed due to geological reasons. Previously, other authors had delved into this topic, such as Uddin [63] who designed an UPHEs in a limestone mine in the USA and Braat et al. [64] who proposed to install an UPHEs in the Netherlands, among others.

#### 2.4. Economic efficiency

While wind and solar technologies have become cheaper over time, energy storage costs have remained high. The UPHEs require a big initial investment difficult to assume for governments or energy companies; e.g. the estimated cost for the Prosper-Haniel project is a 500 M € [62]. Wong [48] estimates that the capital costs for a pumped storage plant are similar to those of an oil-fired plant of analogous size. The largest investment cost of a UPHEs in a mine is underground work, followed by engineering and grid connection. Meyer [36] estimates that underground work increases costs up to 1400€ per kW more than aboveground pumped storages, so hybrid systems, with the upper reservoir at the surface, are preferable –as long as they are publically accepted-. The specific investment costs of a potential UPHEs system planned for the Grund mine (Germany) are approx. 1800 € kW<sup>-1</sup> at a storage capacity of 400 MWh and a pilot plant would cost 180 million € [36]. The costs for the Ingula project (South Africa) are about 1080 € kW<sup>-1</sup> at a storage capacity of 21,000 MWh and the plant would cost almost 8 times more than the German one [38]. These values are in accordance with those stated by Madlener and Specht [54], who estimate that the specific capacity costs for UPHEs in coal mines vary between 1300 and 2000 € kW<sup>-1</sup>, being 2215 € kW<sup>-1</sup> a conservative value calculated in this work. The peak to off-peak price differences in the tariff for big consumers usually renders UPHEs economically viable over the entire year. According to the first study, the technical aspects will not determine the investment, but the uncertainty of the future evolution of the legal framework of the energy market. Notwithstanding, the current transition to clean energies, as well as other macroeconomic aspects, such as the eternal pumping costs in the closed

mines, the environmental benefits or the potential development of socially depressed mining areas, should be taken into account when studying the viability of a UPHEs system in a mine. These systems could aid to face both the long-term the temporal fluctuations of the electrical power supply systems, for which large energy storages are needed, and the short-term fluctuations, thanks to the flexibility and black-start capability of UPHEs.

### 3. Compressed air energy storage

#### 3.1. Underground compressed air energy storage (CAES)

In addition to UPHEs, compressed air energy storage (CAES) systems allow storing a great amount of energy underground, so power generation can be detached from consumption. In this case, the potential energy of a compressed gas (air) is stored in large storage tanks or underground voids. The air pressure is increased by means of electrically driven compressors, which convert the electric energy into potential energy [65,66]. Like PHEs, this technique has been known for a long time (it was seriously investigated in the 1970's [67]), but it is attracting much attention recently as a way to compensate for the intermittency and unpredictability of power generation from renewable energy sources [68]. Both types of energy storage are proven to be sustainable and they have a similar scale and cost (500–2000 € kW<sup>-1</sup>), high capacity and long duration of the storage (hours to months). CAES has low maintenance and it is less restricted by the availability of suitable locations, but PHEs technology is more mature and it has a longer lifetime (40–60 years, compared to 20–40 years for CAES) and usually a higher power rating [69,70].

A CAES system also take advantage of the difference between the peak and off-peak prices, so applications include: peak shaving, spinning reserve, reactive power compensation or VAR support and arbitrage. CAES plants can provide significant energy storage (in the thousands of MWh's) at relatively low costs; they are flexible for providing load management, capable of black start, have fast startup time (they can be brought to full load in less than 10 min) and work efficiently at part load [67,71]. When the energy demand is low, the compressor is typically driven by surplus electricity to produce compressed air, which is stored in a reservoir. When the demand is high, the compressed air is released to drive a turbine, which in turn drives a generator to provide supplement electricity to the grid (the potential energy of the pressurized air is converted to electrical energy). A gas gets warmer when it is compressed, and it gets cold when it expands. To improve the efficiency, the temperature of the air can be reduced during the compression process (the compressors have cooling fins), and preheated in a



combustion chamber before the turbine, since its outflow can be nearly cryogenic [65,70]. There are three types of CAES systems: i) Adiabatic or A-CAES: the heat generated through the compression is used to pre-heat the compressed air, and the cold energy generated by the expansion is used to pre-cool the compressor. ii) Diabatic or D-CAES: a simpler approach which does not include heat exchange, so the heat generated by the compression is released to the atmosphere and the compressed air is pre-heated in a combustion chamber, generally through the combustion of natural gas. iii) isothermal: a quasi-constant temperature is maintained by constant heat exchange to the environment, so the air is compressed to a higher pressure and the expansion does not require gas combustion to deliver energy, but they are only practical for low power rates [70]. Adiabatic systems are more efficient (70%) and less dependent on fossil fuels, so they are the preferred design, since the storage space can be compressed adiabatically with little temperature change and heat loss [67]. Notwithstanding, in adiabatic plants, the storage issue is more significant since larger amount of air is required for generating the same amount of energy of a diabatic CAES [72].

In a D-CAES, the compressed air from the reservoir is mixed with a fuel (natural gas) in the combustion chamber and drives the gas turbine. The power generated by the gas turbine and required by the compressor can be obtained from the following equations:

$$\dot{W}_T = (\dot{m}_a + \dot{m}_{NG}) \cdot (h_{e1} - h_{e2}) \tag{2}$$

$$\dot{W}_C = \dot{m}_a \cdot (h_{c2} - h_{c1}) \tag{3}$$

Where  $\dot{W}_T$  and  $\dot{W}_C$  are the power generated by the turbine and required by the compressor, respectively (kW),  $\dot{m}_a$  and  $\dot{m}_{NG}$  are the mass flow of air and natural gas, respectively ( $\text{kg s}^{-1}$ ),  $(h_{e1}-h_{e2})$  is the difference of the enthalpies in the process of expansion in the gas turbine, and finally  $(h_{c2}-h_{c1})$  is the difference of the enthalpies in the process of compression in the compressor, during charging operations.

The storable amount of energy depends mainly on the capacity of the underground reservoir and the design of the power plant. Considering natural gas with a High Calorific Value (HCV) of  $12,500 \text{ kcal kg}^{-1}$  as the fuel to reheat the compressed air, Fig. 3a shows the energy generated as a function of the volume of the underground reservoir and the temperature of the gas turbine influent. The power depends also on the discharge time of the compressed air stored in the reservoir. If the cycle time is low, the mass flow rate and the power of the gas turbine increase (eq. (2)). Considering a discharge time of 8 h per cycle, the output power of the gas turbine is shown in Fig. 3b.

A single 300 MW CAES plant requires about  $620,000 \text{ m}^3$  of storage space, yielding 8 h of electricity [67]. The storage of a CAES plant should be located in a stable geologic formation deep enough (to safely operate at the required pressure), which must be well sealed (to prevent the air from leaving the storage) and able to withstand the repeated

pressure cycles. The formations should provide the required storage volume at the operating pressure and be permeable to permit the desired flow rates. Compressed air is usually stored underground in salt caverns, hard rock caverns (more prevalent), voids or porous rock formations (saline aquifers) [71]. In Europe, the underground storage in abandoned limestone or coal mines, which have the potential to be outstanding storage sites, is considered [66,67]. These sites have a revisable history of operating conditions, with high storage capacity, available infrastructure and excellent permeability, but it should be relatively close to potential end-users [67]. The very low permeability and self-healing nature of rock salt guarantee its tightness, whereas it has to be ensured in rock caverns, which might require linings or hydrodynamic containment [73–77]. Storage inside coal mines is feasible if the drifts and shafts are correctly sealed, to prevent air leakages and separated from the remaining coal seams, to avoid combustion of coal, collapse or deformation. Overburden integrity and drift stability, as well as water inflow should be carefully controlled. To ensure stability, reduce the likelihood of air leakages, and avoid air contamination, e.g. with mine dust, the cavern surface exposed to rock can be covered with about 5 cm of reinforced shotcrete. Moreover, it can be lined with an impermeable high-strength membrane, such as glass-fiber [73] or airtight sheets of very low-permeability polymeric materials, such as butyl rubber [78]. An advantage of coal mines is that they are often located near power plants, so the energy transport lines are reduced. In addition, the underground geology is known in detail and the cost is reduced, since the voids have been already excavated and there is a large surface area available for the installations. In fact, abandoned coal mines have been efficiently used for natural gas and  $\text{CO}_2$  storage [66,67]. The environmental concerns of a CAES plant are reduced, since the system is underground, the combustion turbine emissions are diluted with the output of the air cycle, humid air injection lowers  $\text{NO}_x$  emissions, and limited water volume is required [67].

There are only a few CAES plants in operation. This probably due to the limitations for the site selection (presence of caverns and favorable geology), the energy losses, and the required additional heating in the expansion process [67]. The first utility-scale CAES system, the 290 MW Huntorf plant, was constructed in Germany in 1978; more than  $310,000 \text{ m}^3$  of compressed air is stored at pressures up to 70 bar in two salt caverns, located up to 790 m below surface. This plant needs 12 h of off-peak energy to fully recharge, and it is capable of providing full power output for up to 4 h and some extra energy for another 10 h. The second plant, the 110 MW McIntosh plant, was built in 1991 in USA. Almost  $540,000 \text{ m}^3$  is stored at pressures up to 75 bar in a salt cavern 760 m deep. This plant can deliver full output for 26 h and since waste heat is recovered, fuel consumption is reduced 25% compared to the Huntorf plant, which combusts natural gas prior to expansion. The availability and reliability is above 90% for both plants [65,67,71]. Other projects have been developed mainly in the USA and China

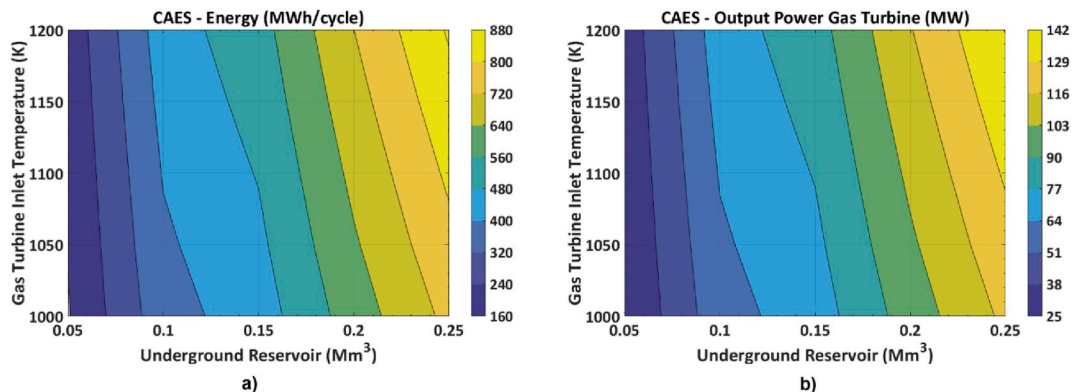

Fig. 3. a) Storable amount of energy per cycle of a CAES plant as a function of the capacity of the underground reservoir and the turbine inlet temperature, considering a turbine efficiency of 78%; b) Output power of the gas turbine considering a cycle time at full load of 8 h.

[70,79], highlighting the hybrid systems, such as the wind turbine-air compressor, which instead of generating electricity, pumps air into CAES, so technical and economic efficiency is improved by eliminating the intermediate electrical generation between the turbine and the air compressor. The Iowa Stored Energy Park was planned to integrate a wind farm with underground CAES, so the excess wind would drive a compressor and be stored underground in a sandstone aquifer for later use, but after years of study it was concluded that this aquifer is not suitable for CAES [65]. Some authors have modelled CAES systems in order to accurately estimate the storage capacity of a certain cavern volume [68] or the safety of the rock mass against uplift failure at high pressure [80].

### 3.2. Economic efficiency

The requirement of additional energy (usually natural gas) in the expansion process -to ensure that maximum energy is acquired from the compressed air-is the major drawback of CAES systems. It is estimated that 1 kWh worth of natural gas is required for every 3 kWh generated from a CAES plant. Thus, the economics of CAES could fail as natural gas prices increase. Notwithstanding, a CAES requires 67% less gas than a gas turbine generator for an equivalent amount of electricity [67] and investment in a diabatic CAES used for load-levelling purposes is the most economical option [70]. Conventional CAES systems have a higher profitability than UPHES plants in a market with low fuel price [72].

For plants with energy storage above 100 MWh or 5 h of capacity, underground storage is more cost-effective. Above ground storage (in gas pipes or pressure vessels) is practical for plants with less than 5–10 h of storage [67]. The project lead times for CAES plants range from one to three years, depending on the size. CAES plants start reliably more than 90% of the time and have 95% operating reliability, showing a good income effect and a good response to the expected risk [81]. A typical 100 MW CAES plant would have an 85% efficiency and cost about 1000 € per kW of storage, with a life of 30 years, and a pay-back period of less than 10 years, but the capacity reduces to 650€ per kW for a 300 MW plant [67,71,81]. In this work, a cost of 960 € kW<sup>-1</sup> has been considered. Though emerging battery technologies also provide wind-balancing services, their capacities and storage volumes are smaller than those of CAES and UPHES plants, with higher costs [71].

## 4. Geothermal heat recovery

### 4.1. Geothermal plants using mine water

Closed and flooded mines provide underground reservoirs of mine water that can be used as a geothermal energy source. Since mining induces fractures in the rock mass, the infiltration of rainwater from the recharge area is enabled, so an intense pumping had to be maintained when the mine was active [82]. This pumping is typically stopped when the mine is closed, leading to the gradual flooding of the mine voids or the so-called groundwater rebound [83]. In the course of the mine flooding, water level rising depends directly on the recharge flow and indirectly on the void volume [82,84,85]. Since uncontrolled discharges of mine water at the surface (through the lowest mine adit or any permeable material hydraulically connected with the flooded mine) are not desirable, pumping is usually resumed and adjusted so the discharge equals the recharge to keep a permanent flood level. This created underground reservoir can be regulated and can be given several uses: geothermal and hydraulic energy generation, industrial or drinking water supply, support of rivers' ecological flow, etc. [82,86]. Mine water is not simply to be perceived as a problem, since it can be regarded as an energy or water source.

The geothermal potential of mine water is widely recognized, and increasing research is being undertaken at mines around the world, especially in coal mines [86–93]. Although most of this research has not

crystallized in full-large scale operating systems, there are some relevant projects in operation in coal fields, such as the Minewater Project, at Heerlen, The Netherlands [94] and the complex geothermal application developed in Mieres, NW Spain [89], which is mentioned later. Hall et al. [86] and Peralta et al. [95] review geothermal projects using mine water around the world.

The temperature of mine water flooding underground mines is isolated from seasonal variations, so it is fairly stable and high enough to be used for geothermal applications. The underground network of galleries and other mine workings can be hundreds of meters deep and they act as an extensive heat exchange interface with the enclosing warm rocks [96]. The water that floods the mine is therefore warmer than the ambient air, and it is stored in the mining reservoir in great quantities. Since the hydraulic conductivity of the reservoir is elevated, due to the created voids and the increased porosity by fracturing, very high water yields can be achieved [96]. Hence, flooded mines have the potential to provide space heating and cooling, by means of heat pumps.

Heat pumps capture the heat from a cold source (mine water in this case) and transfer it to a hot source (e.g. water of the heating circuit, by means of a heat exchanger). The captured heat is used to evaporate a refrigerant, whose temperature is increased by compression; then, the heat is released in the exchanger, and the refrigerant's temperature is reduced again with an expansion valve, so the cycle closes. This cycle can be reversed to provide air-conditioning. The heat pump efficiency is expressed by the coefficient of performance (COP), which is the rate of heat produced by work supplied. A mine water geothermal installation by means of heat pumps will be more efficient the smaller the difference between the temperature of the mine water and the delivered temperature, and the higher the COP of the heat pump, since less energy will be needed to reach the heating or cooling requirements [95]. The success of the system is also influenced by the convenience of mine water in sufficient quantity (available and sustainable water flow, reservoir capacity) and quality, with a stable temperature, as well as heating/cooling demand near the mine [96].

The thermal potential of the cold source is [97]:

$$P_c = \Delta T \cdot F \cdot SH \cdot \rho \quad (4)$$

where  $\Delta T$  is the difference of temperatures of mine water going in and out of the evaporator,  $F$  is the pumped flow,  $SH$  is the specific heat of the water (4186.8 J kg<sup>-1</sup> (°C)<sup>-1</sup>) and  $\rho$  is the density of water (1000 kg m<sup>-3</sup>).

The thermal potential of the warm source is:

$$P_w = P_c \cdot COP \cdot (COP - 1)^{-1} \quad (5)$$

Thus, the work contributed to the compressor of the heat pump is:

$$W_e = P_w - P_c = P_w \cdot COP^{-1} \quad (6)$$

Heat transference from the mine water to the heat pumps can be achieved through different configurations [86]. The most common and simplest are the open-loop systems, in which the mine water is pumped out of the mine and discharged after capturing heat (heating mode) or releasing it (cooling mode). In some cases the spent mine water is re-injected back into the mine, in a separated location to avoid affecting the temperature of the abstracted water, and causing a decline of the efficiency of heat extraction [96]. In the closed-loop systems the heat exchanger is submerged in the mine and a working fluid is circulated to take the heat from the mine water, without contacting it [95]. In the open-loop systems water is usually pumped from the vertical mineshaft. Stratification breakdown due pumping allows for mixing of waters of different temperatures and can potentially lead to negative effects on the thermal resource [98,99]. Numerical models can be used to define the hydrogeological behavior of the mining reservoir and to predict the long-term temperature of the water under different scenarios of exploitation [98,100], in order to define the suitability of flooded mines as a sustainable thermal resource.

#### 4.2. Economic efficiency

The most efficient geothermal systems are those providing heating and cooling simultaneously, particularly those installed in large buildings with similar heating and cooling demands over an annual cycle, such as a hospital [89]. This balanced use allows reaching a high COP of the heat pump and avoids extreme temperatures and the long-term depletion of the geothermal reservoir. The distance of potential users to the mine is a critical efficiency factor, since the cost of pipelines and heat loss can negate the energetic and financial viability of the whole system [96]. A possible solution is to drill a well to reach a gallery to access the mine water, instead of pumping it from the mineshaft, as usual. For a district heating it is possible to install heat pumps in each single building to cover the specific heating requirements or to install a centralized heating plant, which is cheaper. Jardón et al. [89] studied the possibilities of district heating around a coal mineshaft in Asturias (NW Spain) and concludes that a low-temperature network could provide 20 GWh per year for hot water supply, and that all the mines in the region have an annual thermal supply capacity of 260 GWh. Annual energy savings up to 70% compared to conventional sources, reduction of CO<sub>2</sub> emissions of up to 40% per year, and monetary savings up to 20% were achieved in this site [95]. In this work, a cost of 1230 € kW<sup>-1</sup> has been considered. Floor heating is the most effective heat distribution method for low enthalpy sources [95]. New construction buildings are preferable to install adapted heating systems, but the investment in rehabilitation of old households to improve their efficiency and to be directly supplied from the mine water network, is returned in less than 14 years [89]. Another issue affecting efficiency is the fouling, clogging, corrosion or scaling damage that the mine water could cause to the heat exchanger. Mine water hydrochemistry should be taken into account to design the installation [101]. The closed-loop configuration is preferable for mines with poor water quality or when not enough water volume is available [86].

#### 5. Comparative analysis on cost and environmental impacts with conventional systems

The use of closed mines for the implementation of underground energy storage plants and geothermal energy plants has important environment benefits, but usually higher operation and maintenance costs (O&M) compared to conventional systems. PHES is constrained by topography and land availability because it requires a minimum elevation difference between the two reservoirs as well as large storage volumes [102]. In addition, PHES plants are controversial due to their impacts on landscape, land use, environment (vegetation and wildlife) and society [103]. As it was said, in the UPHES using closed mines at least one reservoir is underground and the pipeline and the penstock are installed in the existing shaft, so the impacts are lower than those of conventional PHES. Regarding cost analysis, the investment cost of an UPHES plant (2215 € kW<sup>-1</sup>) is higher than that of a conventional PHES plant (1080 € kW<sup>-1</sup>) [38]. The main difference lies in the construction of the underground reservoir. In the case study presented in this work, where a reservoir capacity of 450,000 m<sup>3</sup> is considered, the cost of the excavation of a surface reservoir is 7.4 M€, while if the reservoir is underground the cost is 127.5 M€. The construction of an underground reservoir also requires a new access tunnel to the powerhouse, which is estimated in 24.9 M€. In addition, UPHES plants require maintaining the ventilation system of the mine, to allow the evacuation of the existing air in the lower reservoir during the operation of the turbine-pump [60]. O&M costs are also slightly higher in UPHES plants compared to conventional PHES plants.

CAES systems work under similar principles as conventional gas turbines, but the compression and expansion phases are decoupled. The lag time between charge and discharge offers the advantage of having the entire power of the gas turbine available during periods of peak load demand. Like UPHES plants, CAES in existing mining voids

reduces environment impacts. In addition, mine water could be used for cooling, when wet cooling systems are employed. The creation of a cavern in hard rock exclusively for a CAES project increases the costs by as much as 80% [104]. The investment cost of a conventional CAES plant in a salt cavern amounts to 828 € kW<sup>-1</sup> [105], while if it is located in a closed coal mine the cost increases to 960 € kW<sup>-1</sup>. In a coal mine, the additional costs of measures to avoid air leakages, such as shotcrete and membranes, should be taken into account. Conventional systems such as Combined Cycle Gas Turbine (CCGT) can reach a capital cost of 952 € kW<sup>-1</sup> [106].

The geothermal use of mine water by means of high efficiency heat pumps offers a low carbon alternative to heat and cool buildings located near closed mines. Submersible pumps located in the mine shafts, circulation pumps and heat pumps (compressor) require electrical energy to operate. Depending on the COP, the emission factor of a geothermal plant using mine water could reach 0.048 kg CO<sub>2</sub> kWh<sup>-1</sup>, much less than conventional plants using fossil fuels: natural gas (0.204 kg CO<sub>2</sub> kWh<sup>-1</sup>), diesel oil (0.287 kg CO<sub>2</sub> kWh<sup>-1</sup>) or electrical energy (0.246 kg CO<sub>2</sub> kWh<sup>-1</sup>) [107]. However, the investment cost of these systems is higher than that of the conventional systems. The economic feasibility of a geothermal plant depends on the distance from the mine to potential users. When the distance increases, the investment cost (a pipeline network must be installed) and the energy consumption by the circulation pumps increase, decreasing the overall efficiency. Investment cost of a geothermal plant with a distance to potential users of 2 km amounts to 1230 € kW<sup>-1</sup>, much more than conventional systems such as natural gas condensing boilers, which can be installed in the center of thermal energy consumption, without pipe network, having an investment cost of about 120 € kW<sup>-1</sup>.

#### 5.1. Uncertainties and risk of using closed mines for energy applications

The use of closed mines for underground energy storage and geothermal applications implies a number of uncertainties and risks which should be considered in a detailed feasibility study. The main risks are related to the use of mine water and underground voids [38]:

- UPHES plants require the construction of large underground reservoirs. Seismic activity in the project area and geotechnical impacts of daily shifting of water mass during the operation stage (turbine and pump mode) should be analyzed. Regarding mine water, water quality (operation of the Francis turbine and corrosion issues) and possible impact of droughts should be studied. Closed mines will continue to be dewatered to maintain the water level below the powerhouse, implying a significant O&M cost. For transporting and housing of large equipment (mainly Francis pump-turbine and motor-generator) new access from surface to powerhouse should be built. O&M costs for maintaining deep infrastructure, including the ventilation system and the underground structures (shafts, tunnel of access, reservoir) make UPHES less profitable.
- CAES technology is relatively slow in discharging the stored power capacity. Due to the high compressed air pressures in the abandoned mines (45–75 bar), geotechnical studies must be carried out. In the case of coal mines, an impermeable high-strength membrane should be installed to prevent air leakages. Like UPHES, for safety reasons, water level should be maintained below the reservoir. CAES design involves fossil fuel combustion in the turbine chambers to provide heat during the expansion phase, with the drawback of CO<sub>2</sub> emissions. Thus, the profitability of the CAES plant depends on natural gas price.
- Geothermal applications are limited to the volume of mine water available. Geochemical parameters of mine water should be analyzed, to prevent corrosion and fouling problems in heat exchanger or heat pumps. The overall efficiency depends on the water temperature. The most significant drawback of using mine water to

heat/cool buildings is the influence of the distance from the mines to the potential users. In many cases, the mines are located far from the urban centers and the projects are not economically feasible.

## 6. Case study: application to Lieres mine (Asturias, Spain)

### 6.1. Study area

For more than two centuries, up to 70% of Spanish coal production came from the Asturian Central Coal Basin (CCB). From late 1980s, mining has resulted in the closure of most coal mines and the extraction is bound to end definitely (only one mine is currently open). In the CCB, mountain mining was first undertaken in general, from the valley level to the highest coal outcrops. It was followed by underground mining, by means of vertical shafts and galleries to access and extract coal several hundreds of m below the valley. The voids generated during decades of coal extraction have created underground reservoirs, whose hydrogeological behavior is similar to a karst aquifer. Some of the abandoned coal mines in the CCB allow the development of different types of projects for the generation of renewable energy.

This study focusses on the Lieres coal mine, located in the Asturian CCB (Fig. 4). Mountain mining was developed in the area from the 18th century, but in 1916 started the underground mining, which lasted up to 2001. The mine has 2 connected vertical shafts, separated a distance of 50 m, reaching a total depth of 780 m, with 16 levels. This is the deepest Asturian mine. This mine was selected for its great depth, because it is very close to potential consumers and because it is classically considered as “dry”, so the pumping costs are reduced.

The geology of the CCB consists of a thick sequence of Upper Carboniferous (Westphalian) sedimentary rocks that includes both transitional and marine lithofacies (lutites, siltstones, coal seams and subordinated limestone levels). The Lieres mine is located in the NE border of the CCB, within the diagenetic domain (vitrinite reflectance 0.5–1% [108]). It is very close to the angular discordance that lays Cretaceous (Aptian) detrital sediments over the Westphalian coal-rich series (Fig. 2). Particularly, the bituminous coal layers exploited in this mine are located in the north flank of a tight anticline, dipping 75° to the north. From a hydrogeological point of view, CCB Westphalian series have low permeability [82].

When the Lieres mine was active, an average water flow of 60,000 m<sup>3</sup> per year was pumped out. It is popularly known as a “dry mine” at a basin scale, since the recharge received by infiltration is much lower than in other mines of the CCB, where it is usual to exceed one million m<sup>3</sup> of water per year. This relatively low recharge is mainly due to the presence of fine-grained impermeable Cretaceous sediments, which does not allow infiltration in the northern part of the mined area. Additionally, the scarce development of mining works up to a depth of almost 300 m below the surface avoids that abundant mining-induced fractures reach the surface and promote infiltration, unlike other mines in the CCB, which often receive infiltration from loser watercourses [82]. The mining voids are now being flooded, creating a hydrogeologically isolated reservoir, due to the low permeability of the enclosing rocks. In 2012 the water level was at a depth of 500 m and since then, it is rising very slowly, with an average rate of 19 m per year, so the mine is currently flooded up to a depth of 370 m from the surface. The rate of water rise was faster in the first flooding phases, due to a lower development of mining works at greater depth.

The average annual temperature in Lieres is 13 °C, and the average rainfall is 830 mm year<sup>-1</sup>. The Thornthwaite evapotranspiration is estimated in 71% of the precipitation, so the annual effective rainfall is 240 mm. The basin that represents the recharge area of the mining reservoir, considering the extent of the mine workings, which might allow water infiltration, extends 8.8 km<sup>2</sup> (Fig. 4). Thus, assuming that the pumped flow equals the recharge within that basin, only approx. 3% of the effective rainfall infiltrates in the mine. This value is much lower than the calculated for other mines in the CCB [82], since the

outcrop materials in the basin are much more impermeable (and less fractured) in this case, as already mentioned. According to the mining company HUNOSA, the galleries in the Lieres mine have a total length of 242 km. The volume of voids was calculated assuming a midsection of 10 m<sup>2</sup> for the galleries and estimating the void left by the extracted coal, obtaining a final volume of 2.5 million m<sup>3</sup>, which is the capacity of the created reservoir. This is the void volume that may be filled with water after complete flooding, if pumping is not resumed. As it was previously stated, the groundwater level in the reservoir is gradually ascending, at a higher rate when there is more precipitation and slower when the mine levels are reached.

In a deep mine such as Lieres, up to three types of systems (those already described) could be carried out. Fig. 5 shows a model of global energetic use inside a closed coal mine like Lieres. Since this mine has two shafts, the UPHES and the CAES can be combined. The largest project is the construction of the UPHES; the upper reservoir is located at the surface, within the mining site, while the lower reservoir is underground, making sure the turbine is above the water level. The pumped warm deep mine water can be used to provide geothermal energy for the heating of the households near the mines. Finally, a CAES plant could be established, using the upper mine galleries for underground air storage; the fact that Lieres is a “dry mine” is ideal for this type of system. Thus, the abandoned mine facilities are efficiently used to generate both electrical and thermal renewable energy.

### 6.2. UPHES system at Lieres mine

The proposed design for an UPHES at Lieres mine includes a rib-shaped lower storage system that has to be built new (Fig. 6). The mineshaft, which is not flooded and easily accessible, can be used to install the penstock, the connection to the electric grid and the ventilation system. A new access tunnel to the powerhouse cavern has to be built from the surface, for transportation of people and materials and as emergency route. A net of concrete-reinforced tunnels, located above the powerhouse, constitutes the lower reservoir, with a capacity of 450,000 m<sup>3</sup>. Transversal tunnels, with a mid-section of 30 m<sup>2</sup>, and a total length of 15 km, are arranged on both sides of a central tunnel. A surge tank can be built in prevention of rapid rises of pressure and to provide extra water if necessary.

The gross head is 450 mH<sub>2</sub>O, but a net head of 439 mH<sub>2</sub>O is considered (80 m below the current flood level in the reservoir). Below the lower reservoir, some mine voids are kept dry to create extra water storage capacity from a possible pipe burst, so any escaping water circulates down the shaft, preventing the damage of the powerhouse. Assuming that the systems operates 4 h per day at full-load, with a water flow of 30 m<sup>3</sup> s<sup>-1</sup>, and a turbine power of 116 MW (eq. (1)), whose efficiency is 90%, the power generation of the facility per cycle would be 464 MWh. This value is in accordance to other similar projects [59]. The power of the pump, whose efficiency is 80% is estimated in 92 MW. The generation of energy would be 153 GWh year<sup>-1</sup> and the electricity consumption would be 195 GWh year<sup>-1</sup>.

Underground hard-rock excavations are very costly, so the relatively inexpensive raise-bore technique is preferable, when possible. The total cost of the project is estimated in 257 million euros and the cost per kW is 2215 € (Table 3). The project is believed to be economically feasible. As it represents a sustainable post-mining solution, economic incentives in the form of tax breaks or subsidies that otherwise would have to be spent on legacy water issues, should be desirable [38].

This is only a preliminary assessment of the feasibility of using the existing coal mine infrastructure for the potential development of an UPHES in Asturias, and the Lieres mineshaft has been selected as one of the most convenient locations to develop such a project. Notwithstanding, the authors believe that the construction of a UPHES pilot plant at this site is in principle possible in technical, legal, environmental and economic terms. A future detailed plan and cost-benefit analysis would be the next phase.



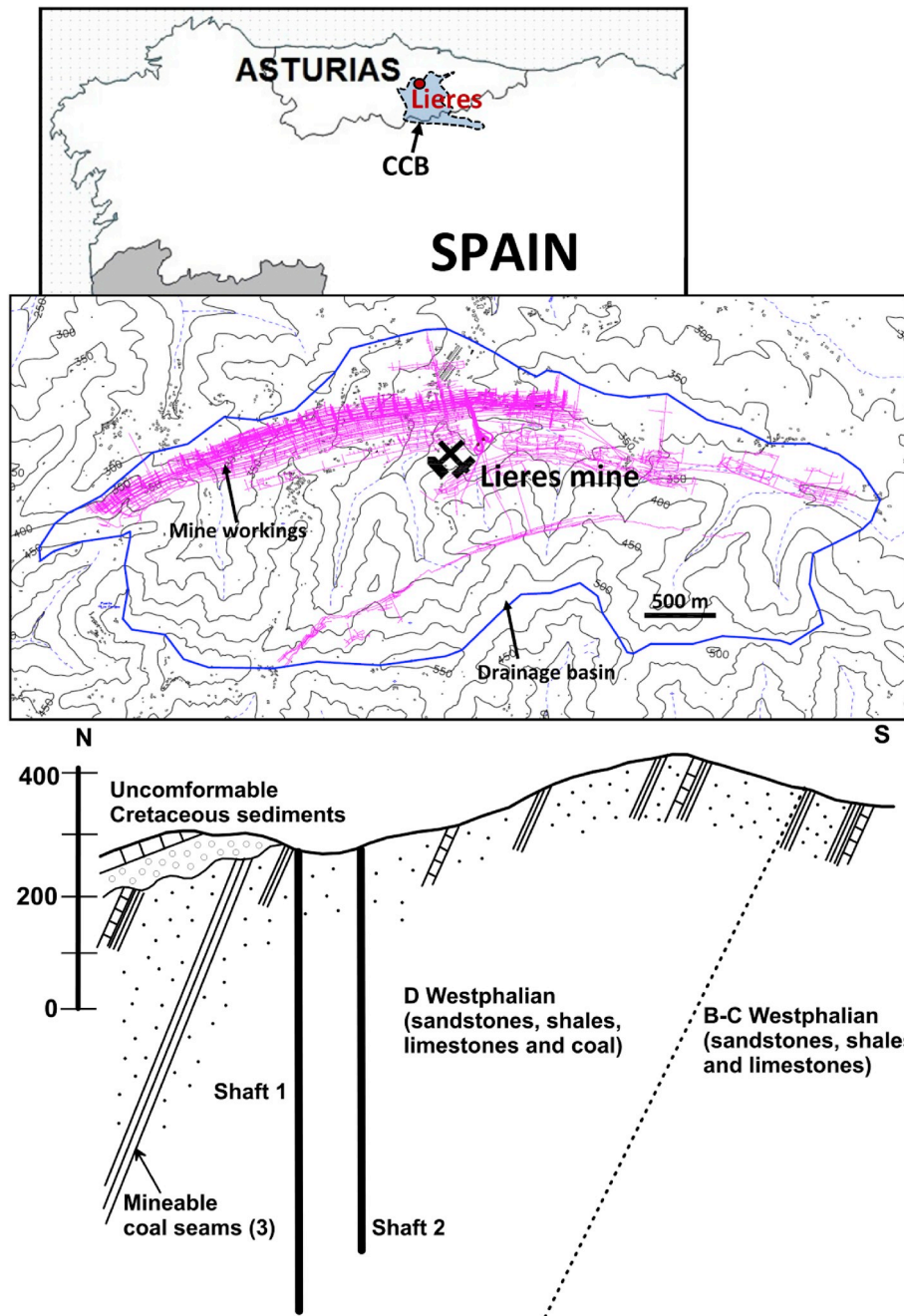

Fig. 4. Location of the study area. Horizontal projection of the workings and recharge basin of the Lieres mine. North-South geological section across the Lieres shafts.

### 6.3. CAES system at Lieres mine

In this case, a diabatic CAES system is proposed, so the stored air is preheated before the combustion with the help of the hot exhaust gas, which leads to an increase of process efficiency. Thermal cycling of compression heat and exhaust heat recuperation strongly influence the process efficiency [109]. During compression a high temperature is reached that could exceed the capability of the compressor and of the air storage. Thus, compression is usually subdivided in several stages, intermitted by intercooling and followed by an after cooler. The design considers 4 intercooled compressor stages and a heat recovery system that optimizes the efficiency of the plant and reduces the consumption of natural gas. Fig. 7 shows the proposed system design and the temperature-entropy (T-s) diagram of the plant. The upper part of the mine voids would be used for the storage. This include the galleries of four

mine levels, with an average cross section of 10 m<sup>2</sup>, and a total length above 15 km, together with the shaft volume, adding up a total volume of 182,000 m<sup>3</sup> (above the water level). The galleries should be sealed and reinforced with concrete, and isolated with materials able to withstand high storage pressures (45–75 bar), avoiding contact with coal. Uniaxial compression tests performed in the study area show a resistance values of 150 and 50 MPa for the sandstone and the shale, respectively, which are higher than the resistance measured at caverns considered stable for pressurized underground storage [110].

Table 2 shows the considered parameters of the air compression and expansion stages and other characteristics of the CAES. The power of the plant is 105 MW. The charge time of each cycle is 10 h while the discharge time of each cycle is 8 h. The energy per cycle, considering an efficiency of 78%, is 655 MWh and the annual energy production is 197 GWh.

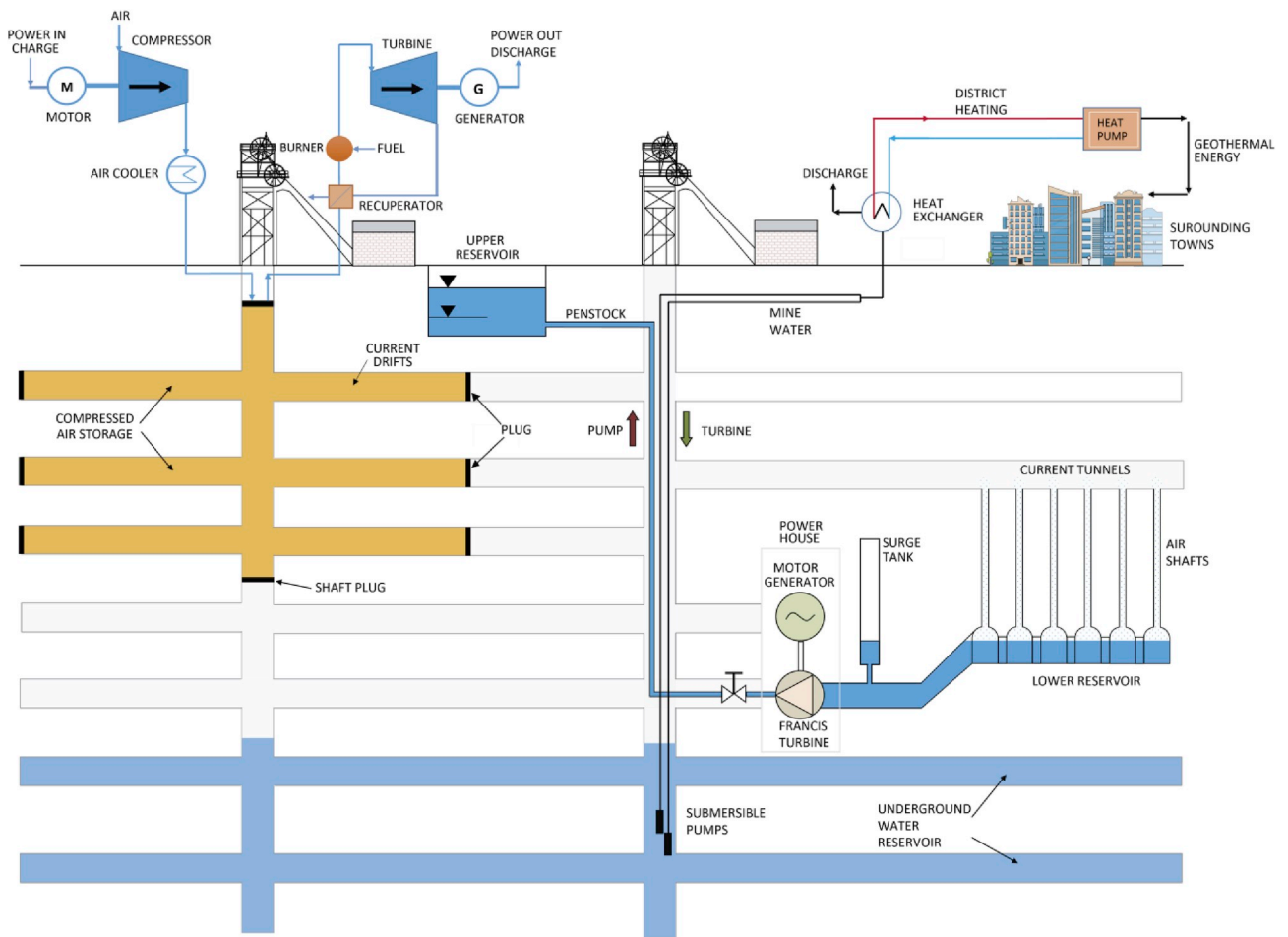

Fig. 5. Combined design of underground energy storage systems (UPHES and CAES) and geothermal utilization in an abandoned underground coal mine.

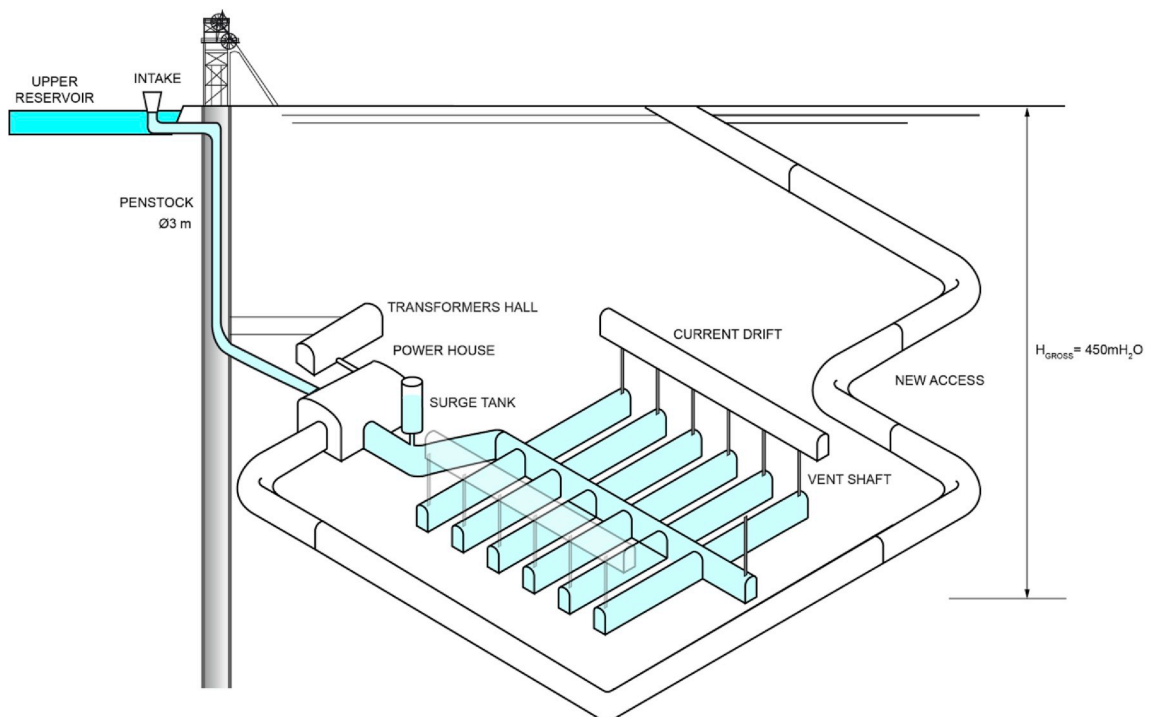

Fig. 6. Design of the UPHES plant in the studied underground coal mine.

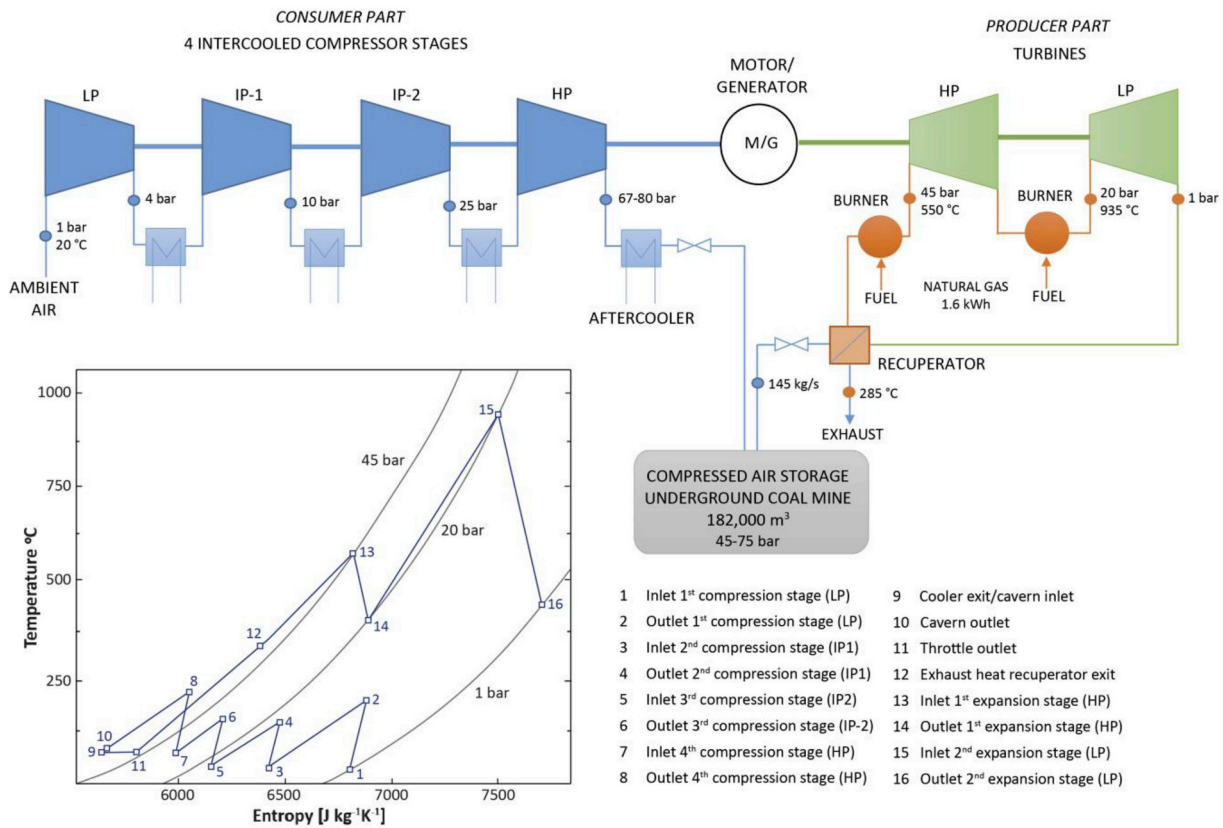

Fig. 7. Schematic layout for the CAES plant proposed for the studied underground coal mine and corresponding T-s diagram with the main points of the cycle.

**Table 2**  
Main characteristics of the CAES plant.

Cycle Efficiency	52%
Energy input for 1 kWh <sub>e</sub>	1.6 kWh <sub>gas</sub>
Energy content per cycle	655 MWh
<b>Compression</b>	
Max. Electricity input	55 MW
Max. Air mass flow rate	100 kg s <sup>-1</sup>
<b>Expansion</b>	
Max. Electricity output	105 MW
Control range	20–105 MW
Max. Mass flow rate	145 kg s <sup>-1</sup>
Control range	20–105 MW
Max. Mass flow rate	145 kg s <sup>-1</sup>

6.4. Geothermal use of Lieres mine water

Mine water in other mines of the CCB is usually at a temperature > 20 °C at a depth below 100 m. The upper sections of the mines display seasonal temperature variations, whereas the temperature is more stable in the lower parts of them. Water temperatures reported from other mines studied for geothermal purposes range from less to 12–21 °C [86], so the mining reservoirs in the CCB constitute an attractive resource. In particular, the water that could be eventually pumped from the Lieres mine, is expected to have a promising temperature, given the depth of this mine and its scarce recharge from rainfall. Water from other mining reservoir in the CCB (at Mieres) is currently used as a geothermal resource to supply heating and cooling to several public buildings (including a hospital), and district heating projects using this and other mining reservoir are ongoing [101]. The currently exploited mining reservoir has been extensively studied and modelled to define technical, economical and long-term feasibility [89,98]. Thus, there is a wide theoretical and practical experience in the region about this type of applications, which have public acceptance.

The water level is currently at a depth of 370 m inside the mine but, according to the groundwater rebound, it is ascending and eventually the water recharging the reservoir will have to be permanently pumped to maintain a safe flood level. In that case, this pumped water would be discharged to a local watercourse, but it could be used as a geothermal resource instead. In order to combine this use with the proposed UPHEs, the current water level should be depressed below 450 m of depth. The village of Lieres has 1500 inhabitants and their residential homes, as well as a projected industrial park, are located near the mine and could be potential end users.

The geothermal gradient in the studied area varies from 0.027 to 0.032 °C m<sup>-1</sup> [111], so if average value of 0.03 °C m<sup>-1</sup> is considered, the mine water would be around 26 °C at a depth of 450 m. According to eq. (4), if a heat pump that extracts 5 °C worth of heat from the mine water, considering a pumped annual flow of 60,000 m<sup>3</sup>, 1700 h year<sup>-1</sup> for heating [97], the heat available is: P<sub>c</sub> = 0.21 MW. To produce hot water at 35 °C, a COP = 6.73 can be considered [89]. Applying equations (3) and (4), the thermal potential of the warm source is P<sub>w</sub> = 0.24 MW and the work contributed to the compressor of the heat pump is W<sub>e</sub> = 0.04 MW. Thus, a heat pump available 1700 h per year would produce 410 thermal MWh, consuming 60.9 electrical MWh. Since the mine water has to be pumped anyway to keep a safe flood level, the economic feasibility of the system is patent.

Fig. 8 shows a scheme of a possible geothermal installation, where a heat pump is fed from a tank of mine water (for example, at a conservative temperature of 19 °C), providing cold water for cooling at 7 °C and hot water for heating at 50 °C [89].

6.5. Energy balance and investment costs

Table 3 shows a comparative analysis between the generation plants that have been proposed in the case study: the power generation (UPHEs and CAES) plants, applied for the adjustment of the electrical system, and

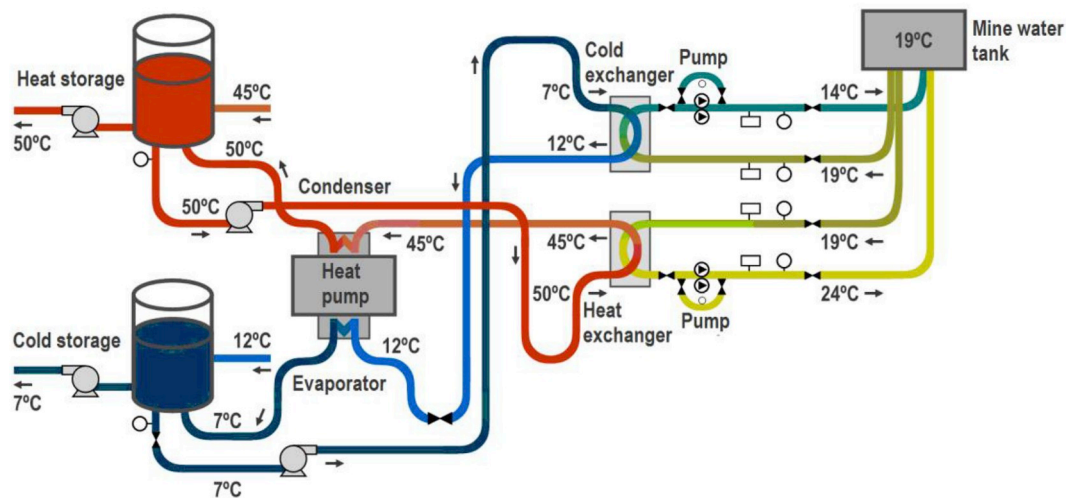

Fig. 8. Scheme of a mine water heat pump with heat and cold storage [89].

Table 3

Comparative analysis between the proposed UPHES, CAES and geothermal plants in terms of energy production and investment costs.

	UPHES	CAES	GEOTHERMAL
Power (MW)	116	105	0,24
Energy Generation (GWh year <sup>-1</sup> )	153	197	0,41
Investment cost (M€)	257	101	0,30
Investment cost (€/kW)	2215	960	1230

the thermal power generation plant, applied for heating. Although in general an UPHES is more effective than a CAES, the particular characteristics of the proposed systems in this case study determine that the full load time is higher in the CAES, which generates more energy per year. Expanding the reservoir volume could increase the energy generated by the UPHES. The geothermal installation is the least expensive, but given that the energy generation is relatively low (due to the low water flow), it has the highest price per kW. The energy production could be improved if a higher water flow could be pumped from the mine, if recharge is increased, injecting external water from a river, for example.

### 7. Conclusions

The use of mine shafts and voids for UPHES and CAES is technically feasible and especially useful in the context of a transition to renewable energy with competitive economics, and that is also the case for geothermal use of mine water. In particular, this paper shows the technical viability of a UPHES potentially implementable in an abandoned coal mine, combined with a CAES plant and co-generation of geothermal energy. The proposed systems confirmed the expected high efficiency, reliability and availability. The economic feasibility still has a high level of uncertainty and needs to be refined in future phases.

Conditions at some EU mines were found to be favorable for further exploration and implementation of the UPHES and CAES concepts and the geothermal applications, which can be extrapolated to other mining areas worldwide. A joint venture between the mining company and the energy provider companies would be ideal for the exploitation of the resource. The main restrictions to be considered for the design of an energy system in a mine are:

- engineering, operational and economic requirements, which define the feasibility of the project,
- geological, geotechnical and hydrogeological parameters which might affect the stability of the reservoir and the water flow and quality,

- legal and societal factors, which should be taken into account to avoid discontent in nearby communities and to guarantee the success of the project.

The economic viability of a UPHES, a CAES or a geothermal installation using mining structures should not be based simply on the energy generation, but also on its potential to avoid the post-closure water pumping and treatment costs and other benefits, sometimes intangible. These systems:

- save CO<sub>2</sub> emissions, helping to meet growing international demand for non-carbon based energy,
- give stability to the energy market, allowing for fluctuating solar and wind energy integration into the grid through flexible energy storage and
- stimulate social and economic development of the former mining areas, creating favorable conditions for other activities through reliable electrical and thermal energy, as well as water supply.

The use of closed mines for underground energy storage plants and geothermal applications has significant environment advantages, but typically higher operation and maintenance costs compared to conventional systems. The case study shows an UPHES system with a reservoir capacity of 0.45 Mm<sup>3</sup> and a net head of 450 mH<sub>2</sub>O, a CAES system with a reservoir capacity of 0.18 Mm<sup>3</sup> at 45–75 bar, and a geothermal system using a mine water flow of 21 s<sup>-1</sup>, which could generate 153, 197 and 0.41 GWh year<sup>-1</sup>, at a cost of 257, 101 and 0.3 M€, respectively. The individual characteristics of each system, such as the reservoir volume, define their profitability.

Thus, the abandoned mines are turned into assets generating energy and providing new resources instead of residues. These projects are particularly appealing for countries that have a large number of abandoned (coal) mines, to switch from high-emission conventional fossil fuels to low-emission renewable energy.

### Acknowledgements

Authors thank the mining company HUNOSA for providing valuable information.

### References

- [1] International Energy Agency (IEA). World energy outlook. 2018 <https://www.iea.org/weo2018>, Accessed date: 23 November 2018 2018.
- [2] EC. 2030 energy strategy. 2017 <https://ec.europa.eu/energy/en/topics/energy->



- strategy/2030-energy-strategy. Accessed date: 19 November 2018.
- [3] European Environment Agency (EEA), Share of renewable energy in gross final energy consumption. Eurostat Renewable energy statistics, [https://ec.europa.eu/eurostat/statistics-explained/index.php/Renewable\\_energy\\_statistics](https://ec.europa.eu/eurostat/statistics-explained/index.php/Renewable_energy_statistics); 2108 [accessed 14 November 2018].
- [4] Corbijn LJ. Benefits of underground pumped hydro storage (UPHS) in the Dutch power system. Unpublished Master's Thesis. Utrecht University; 2017 Available from: <https://dspace.library.uu.nl/handle/1874/355818>.
- [5] Stram B. Key challenges to expanding renewable energy. *Energy Policy* 2016;96:728–34.
- [6] Wolkersdorfer C. Water management at abandoned flooded underground mines: fundamentals, tracer tests, modelling, water treatment. Heidelberg: Springer; 2008.
- [7] European Commission (Directorate-General for Energy Internal Energy. The role of gas storage in internal market and in ensuring security of supply Available from: <https://ec.europa.eu/energy/sites/ener/files/documents/REPORT-Gas%20Storage-20150728.pdf>; 2015.
- [8] Díez R, Díaz-Aguado M. Estimating limits for the geothermal energy potential of abandoned underground coal mines: a simple methodology. *Energies* 2014;7(7):4241–60.
- [9] Geologischer dienst Nordrhein-Westfalen. 2019 [https://www.gd.nrw.de/ro\\_er.htm](https://www.gd.nrw.de/ro_er.htm), Accessed date: 4 March 2019.
- [10] Schlotte W. Control of heat and humidity in German mines. In: Tien JC, editor. Proceedings of the 8th US mine ventilation symposium. Rolla; 1999. p. 357–63. Available from: <https://scholarsmine.mst.edu/cgi/viewcontent.cgi?article=1054&context=usmvms>.
- [11] Doring M, Reese R. Anbindung der Zollvereinpartien an den Schacht 10 auf der 7. Sohle des Bergwerks Prosper-Haniel. Germany: Thyssen Mining Report; 2010. p. 5–7.
- [12] Gombert P, Sracek O, Koukouzas N, Gzyl G, Tuñón S, Frączek R, et al. An overview of priority pollutants in selected coal mine discharges in Europe. *Mine Water Environ* 2018;38(1):16–23 <https://dx.doi.org/10.1007/s10230-018-0547-8>.
- [13] Alves Dias P, Kanellopoulos K, Medarac H, Kapetaki Z, Miranda-Barbosa E, Shortall R, et al. EU coal regions: opportunities and challenges ahead. Luxembourg: EUR 29292 EN, Publications Office of the European Union; 2018 Available from: <https://ec.europa.eu/jrc/en/publication/eur-scientific-and-technical-research-reports/eu-coal-regions-opportunities-and-challenges-ahead>.
- [14] Collon P, Steckiewicz-Laurent W, Pellerin J, Laurent G, Guillaume Caumon G, Reichart G, et al. 3D geomodelling combining implicit surfaces and Voronoi-based remeshing: a case study in the Lorraine Coal Basin (France). *Comput Geosci* 2015;77:29–43 <https://dx.doi.org/10.1016/j.cageo.2015.01.009>.
- [15] Denimal S, Tribouvillard N, Barbecot F, Dever L. Leaching of coal-mine tips (Nord-Pas-de-Calais coal basin, France) and sulphate transfer to the chalk aquifer: example of acid mine drainage in a buffered environment. *Environ Geol* 2002;42:966–81 <https://dx.doi.org/10.1007/s00254-002-0602-3>.
- [16] Denimal S, Bertrand C, Mudry J, Paquette Y, Hochart M, Steinmann M. Evolution of the aqueous geochemistry of mine pit lakes – blanzly–Montceau-les-Mines coal basin (Massif Central, France): origin of sulfate contents; effects of stratification on water quality. *Appl Geochem* 2005;20:825–39 <https://dx.doi.org/10.1016/j.apgeochem.2004.11.015>.
- [17] Hamm V, Sabet B. Modelling of fluid flow and heat transfer to assess the geothermal potential of a flooded coal mine in Lorraine. France. *Geothermics* 2010;39:177–86 <https://dx.doi.org/10.1016/j.geothermics.2010.03.004>.
- [18] Wojtkowiak F, Couillet J-C, Daupley X, Tauziède C. Geotechnical and environmental impacts on the surface of the water rising in French underground coal mines after closure. proceedings of the 7th IMWA international congress, Ustron (Poland). IMWA; 2000. p. 180–94.
- [19] Corbel S, Kaiser J, Vicentin S. Coal mine flooding in the Lorraine-Saar basin: experience from the French mines. In: Wolkersdorfer C, Sartz L, Sillanpää M, Häkkinen A, editors. Proceedings of the 13th IMWA international congress, Rauhia (Finland). IMWA; 2017. p. 161–6.
- [20] Alhamed M, Wöhllich S. Environmental impact of the abandoned coal mines on the surface water and the groundwater quality in the south of Bochum, Germany. *Environ Earth Sci* 2014;72(9):3251–67 <https://dx.doi.org/10.1007/s12665-014-3230-9>.
- [21] Müller M. Water drainage in the German coal mining after the close-down in 2018. In: Drebenstedt C, Michael P, editors. Proceeding of the IMWA symposium 2016. Leipzig (Germany): IMWA; 2016. p. 624–9.
- [22] Drobniowski M, Balzer I, Frankenhoff H, Witthaus H. Mine water management in the Ruhr coalfield. In: Drebenstedt C, Michael P, editors. Proceedings of the IMWA symposium 2016. Leipzig (Germany): IMWA; 2016. p. 184–8.
- [23] Janusz K, Ewa J, Antoni C. Changes of hydrogeological conditions in the area of liquidated hard coal mines in the north-eastern part of Upper Silesia Coal Basin (southern Poland). In: Loredó J, Pendas F, editors. Proceedings of the 9th IMWA international congress. Oviedo (Spain): IMWA; 2005. p. 209–15.
- [24] Bukowski P, Wagner J, Witkowski A. Use of void space in abandoned mines in the upper silesia Coal Basin (Poland). In: Cidu R, Frau F, editors. Proceedings of the IMWA symposium 2007. Cagliari (Italy): IMWA; 2007. p. 147–51.
- [25] Bukowski P. Water hazard assessment in active shafts in upper silesian Coal Basin mines. *Mine Water Environ* 2011;30:302–11 <https://dx.doi.org/10.1007/s10230-011-0148-2>.
- [26] Bailey MT, Gandy CJ, Watson IA, Wyatt LM, Jarvis AP. Heat recovery potential of mine water treatment systems in Great Britain. *Int J Coal Geol* 2016;164:77–84 <https://dx.doi.org/10.1016/j.coal.2016.03.007>.
- [27] Wolkersdorfer C, Bowell R. Contemporary reviews of mine water studies in Europe, Part 1. *Mine Water Environ* 2004;23:162–82. <https://doi.org/10.1007/s10230-004-0060-0>.
- [28] Wolkersdorfer C, Bowell R. Contemporary reviews of mine water studies in Europe, Part 3. *Mine Water Environ* 2005;24:58–76 <https://dx.doi.org/10.1007/s10230-005-0074-2>.
- [29] Johnston D, Potter H, Jones C, Rolley S, Watson I, Pritchard J. Abandoned mines and the water environment. Bristol: Environment Agency; 2008 Available from: [https://assets.publishing.service.gov.uk/government/uploads/system/uploads/attachment\\_data/file/291482/LIT\\_8879\\_df7d5c.pdf](https://assets.publishing.service.gov.uk/government/uploads/system/uploads/attachment_data/file/291482/LIT_8879_df7d5c.pdf).
- [30] Gillhaus A, Horvath PL. Compilation of geological and geotechnical data of worldwide domal salt deposits and domal salt cavern fields Submitted PA, USA; Solution Mining Research Institute; 2007. p. 109. Research Report, Clarks Submit.
- [31] Barbour E, Wilson IG, Radcliffe J, Ding Y, Li Y. A review of pumped hydro energy storage development in significant international electricity markets. *Renew Sustain Energy Rev* 2016;61:421–32 <https://dx.doi.org/10.1016/j.rser.2016.04.019>.
- [32] Gallo AB, Simões-Moreira JR, Costa H, Santos MM, Moutinho dos Santos E. Energy storage in the energy transition context: a technology review. *Renew Sustain Energy Rev* 2016;65:800–22 <https://dx.doi.org/10.1016/j.rser.2016.07.028>.
- [33] Guittet M, Capezali M, Gaudard L, Romero F, Vuille F, Avellan F. Study of the drivers and asset management of pumped-storage power plants historical and geographical perspective. *Energy* 2016;111:560–79 <https://dx.doi.org/10.1016/j.energy.2016.04.052>.
- [34] Rehman S, Al-Hadhrami L, Alam M. Pumped hydro energy storage system: a technological review. *Renew Sustain Energy Rev* 2015;44:586–98 <https://dx.doi.org/10.1016/j.rser.2014.12.040>.
- [35] Yang CJ, Jackson RB. Opportunities and barriers to pumped-hydro energy storage in the United States. *Renew Sustain Energy Rev* 2011;15(1):839–44 <https://dx.doi.org/10.1016/j.rser.2010.09.020>.
- [36] Meyer F. Storing wind energy underground. Berlin: Federal Ministry for the Environment, Nature Conservation and Nuclear Safety; 2013 Available from: [http://www.bine.info/fileadmin/content/Presse/Projectinfos\\_2013/PM\\_18\\_2013/Projektinfo\\_1813\\_engl\\_internetx.pdf](http://www.bine.info/fileadmin/content/Presse/Projectinfos_2013/PM_18_2013/Projektinfo_1813_engl_internetx.pdf).
- [37] Berrada A, Loudiyi K. Operation, sizing, and economic evaluation of storage for solar and wind power plants. *Renew Sustain Energy Rev* 2016;59:1117–29 <https://dx.doi.org/10.1016/j.rser.2016.01.048>.
- [38] Winde F, Kaiser F, Erasmus E. Exploring the use of deep level gold mines in South Africa for underground pumped hydroelectric energy storage schemes. *Renew Sustain Energy Rev* 2016;78:668–82 <https://dx.doi.org/10.1016/j.rser.2017.04.116>.
- [39] Chen H, Cong TN, Yang W, Tan C, Li Y, Ding Y. Progress in electrical energy storage system: a critical review. *Prog Nat Sci* 2009;19(3):291–312 <https://doi.org/10.1016/j.pnsc.2008.07.014>.
- [40] DOE global energy storage database [internet]. Sandia National laboratories. 2018 Available from: [www.energystorageexchange.org](http://www.energystorageexchange.org).
- [41] Gimeno-Gutiérrez M, Lacal-Arántegui R. Assessment of the European potential for pumped hydropower energy storage based on two existing reservoirs. *Renew Energy* 2015;75:856–68 <https://doi.org/10.1016/j.renene.2014.10.068>.
- [42] Ming Z, Kun Z, Daoxin L. Overall review of pumped-hydro energy storage in China: status quo, operation mechanism and policy barriers. *Renew Sustain Energy Rev* 2013;17:35–43 <https://doi.org/10.1016/j.rser.2012.05.024>.
- [43] Evans A, Strezov V, Evans TJ. Assessment of utility energy storage options for increased renewable energy penetration. *Renew Sustain Energy Rev* 2012;16(6):4141–7 <https://doi.org/10.1016/j.rser.2012.03.048>.
- [44] Deane JP, Gallachóir BPO, McKeogh EJ. Techno-economic review of existing and new pumped hydro energy storage plant. *Renew Sustain Energy Rev* 2010;14(4):1293–302 <https://doi.org/10.1016/j.rser.2009.11.015>.
- [45] Ibrahim H, Ilinca A, Perron J. Energy storage systems: characteristics and comparisons. *Renew Sustain Energy Rev* 2008;12(5):1221–50 <https://doi.org/10.1016/j.rser.2007.01.023>.
- [46] Schoenung SM, Eyer JM, Iannucci JJ, Horgan SA. Energy Storage for a competitive power market. *Annu Rev Energy Environ* 1996;21(1):347–70 <https://doi.org/10.1146/annurev.energy.21.1.347>.
- [47] Fessenden RA. The commercial solution of the problem of utilising, for the production of power, the energy of solar radiation, the wind and other intermittent natural sources. *The Electrician* 1910;65:951–3.
- [48] Wong IH. An underground pumped storage scheme in the Bukit Timah Granite of Singapore. *Tunn Undergr Space Technol* 1996;11(4):485–9 [https://doi.org/10.1016/S0886-7798\(96\)00035-1](https://doi.org/10.1016/S0886-7798(96)00035-1).
- [49] Pujades E, Willems T, Bodeux S, Orban P, Dassargues A. Underground pumped storage hydroelectricity using abandoned works (deep mines or open pits) and the impact on groundwater flow. *Hydrogeol J* 2016;24(6):1531–46 <https://doi.org/10.1007/s10040-016-1413-z>.
- [50] Pickard WF. The history, present state, and future prospects of underground pumped hydro for massive energy storage. *Proc IEEE* 2012;100(2):473–83 <https://doi.org/10.1109/JPROC.2011.2126030>.
- [51] Scott FM. Hydropower from underground pumped storage. *Energy Sources* 2007;2(2):217–27 <https://doi.org/10.1080/00908317508945949>.
- [52] Tam SW, Blomquist CA, Kartsounes DT. Underground pumped hydro storage: an overview. *Energy Sources* 1979;4(4):329–51 <https://doi.org/10.1080/00908317908908068>.
- [53] Bodeux S, Pujades E, Orban P, Brouyère S, Dassargues A. Interactions between groundwater and the cavity of an old slate mine used as lower reservoir of an UPHS (Underground Pumped Storage Hydroelectricity): a modelling approach. *Eng Geol* 2017;217:71–80 <https://doi.org/10.1016/j.enggeo.2016.12.007>.
- [54] Madlener R, Specht JM. An exploratory economic analysis of underground pumped-storage hydro power plants in abandoned coal mines Aachen: Institute for

- Future Energy Consumer Needs and Behavior Working Paper No. 2/2013 2013 Available from: [https://papers.ssrn.com/sol3/papers.cfm?abstract\\_id=2350106](https://papers.ssrn.com/sol3/papers.cfm?abstract_id=2350106).
- [55] Pujades E, Orban P, Bodeux S, Archambeau P, Ercicum S, Dassargues A. Underground pumped storage hydropower plants using open pit mines: how do groundwater exchanges influence the efficiency? *Appl Energy* 2017;190:135–46 <https://doi.org/10.1016/j.apenergy.2016.12.093>.
- [56] Harza RD. Hydro and pumped storage for peaking. *Power Eng* 1960;64(10):79–82.
- [57] Menéndez J, Loredó J, Fernández M, Galdo M. Underground pumped-storage hydro power plants with mine water in abandoned coal mines. In: Wolkersdorfer C, Sartz L, Sillanpää M, Häkkinen A, editors. Proceedings of the 13th IMWA international congress. Rahua (Finland): IMWA; 2017. p. 6–13.
- [58] Özarslan A, Aydiner HY, Köken E, Alber M. Stability analysis of deep coal mine main roadways for pumped hydropower lower reservoir storage. In: Kwasniewski M, Lydzba D, editors. Rock mechanics for resources, energy and environment. Proceedings of EUROCK2013. Wrocław (Poland). Taylor & Francis; 2013. p. 587–92.
- [59] Alvarado R, Niemann A, Wortberg T. Underground pumped-storage hydroelectricity using existing coal mining infrastructure. In: Mynnet A, editor. Deltas and the future and what happens upstream. E-proceedings of the 36th IAHR world congress. The Hague (Netherlands): IAHR; 2015.
- [60] Menéndez J, Loredó J, Galdo M, Fernández-Oro JM. Energy storage in underground coal mines in NW Spain: assessment of an underground lower water reservoir and preliminary energy balance. *Renew Energy* 2018;134:1381–91 <https://doi.org/10.1016/j.renene.2018.09.042>.
- [61] Williams D. Coal mine to be transformed into 200 MW pumped hydro plant. *Power Engineering International*; 2017 Available from: <https://www.powerengineeringint.com/articles/2017/03/coal-mine-to-be-transformed-into-200-mw-pumped-hydro-plant.html>.
- [62] Andrews R. A brief review of underground coal mine energy storage. *Energy matters; Energy, Environment and Policy*. 2017 Available from: <http://euannearns.com/a-brief-review-of-underground-coal-mine-energy-storage/>.
- [63] Uddin N. Preliminary design of an underground reservoir for pumped storage. *Geotech Geol Eng* 2003;21:331–55 <https://dx.doi.org/10.1023/B:GEGE.0000006058.79137.e2>.
- [64] Braat KB, Van Lohuizne HPS, De Haan JF. Underground pumped hydro-storage project for The Netherlands. *Tunnels and Tunneling* 1985;17:19–22.
- [65] Gardner J, Haynes T. Overview of compressed air energy storage. Report ER-07-001. Boise state university: office of energy research, policy and campus sustainability 2007 Available from: <https://www.necce.org/files/compressedair.pdf>.
- [66] Lutyński M. An overview of potential benefits and limitations of Compressed Air Energy Storage in abandoned coal mines. *IOP Conf Ser Mater Sci Eng* 2017;268: conference 1 <https://dx.doi.org/10.1088/1757-899X/268/1/012006>.
- [67] Layton L. Compressed air energy storage. Fairfax: PDH online course E365: 2012 Available from: <https://pdhonline.com/courses/e365/e365content.pdf>.
- [68] He W, Luo X, Evans D, Busby J, Garvey S, Parkes D, et al. Exergy storage of compressed air in cavern and cavern volume estimation of the large-scale compressed air energy storage system. *Appl Energy* 2017;208:745–57 <https://doi.org/10.1016/j.apenergy.2017.09.074>.
- [69] Wang J, Lu K, Ma L, Wang J, Dooner M, Miao S, et al. Overview of compressed air energy storage and technology development. *Energies* 2017;10(7):991 <https://dx.doi.org/10.3390/en10070991>.
- [70] Wang J, Ma L, Lu K, Miao S, Wang D, Wang J. Current research and development trend of compressed air energy storage. *Systems Science and Control Engineering* 2017;5(1):434–48 <https://doi.org/10.1080/21642583.2017.1377645>.
- [71] Succar S, Williams RH, Cavallo AJ, Christopher CK, Denholm P, Dekenberger D, et al. Compressed air energy storage: theory, resources, and applications for wind power. Princeton: Princeton Environmental Institute; 2008 Available from: [https://acee.princeton.edu/wp-content/uploads/2016/10/SuccarWilliams\\_PEI\\_CAES\\_2008April8.pdf](https://acee.princeton.edu/wp-content/uploads/2016/10/SuccarWilliams_PEI_CAES_2008April8.pdf).
- [72] Bozzolani E. Techno-economic analysis of compressed air energy storage systems. Cranfield: School of Engineering, Cranfield University; 2010 Available from: [https://dspace.lib.cranfield.ac.uk/bitstream/handle/1826/6786/EMANUELE\\_BOZZOLANI\\_THESIS\\_2010.pdf?sequence=1&isAlloewd=y](https://dspace.lib.cranfield.ac.uk/bitstream/handle/1826/6786/EMANUELE_BOZZOLANI_THESIS_2010.pdf?sequence=1&isAlloewd=y).
- [73] Geissbühler L, Becattini V, Zanganeh G, Zavattoni S, Barbato M, Haselbacher A, et al. Pilot-scale demonstration of advanced adiabatic compressed air energy storage, Part 1: plant description and tests with sensible thermal-energy storage. *J Energy Storage* 2018;17:129–39 <https://dx.doi.org/10.1016/j.est.2018.02.004>.
- [74] Bérest P, Brouard B. Safety of salt caverns used for underground storage. *Oil Gas Sci Technol* 2003;58(3):361–84 <https://doi.org/10.2516/ogst.2003023>.
- [75] Goodall DC, Åberg B, Brekke TL. Fundamentals of gas containment in unlined rock caverns. *Rock Mech Rock Eng* 1988;21(4):235–58 <https://doi.org/10.1007/BF01020278>.
- [76] Kovári K. Basic consideration on storage of compressed natural gas in rock chambers. *Rock Mech Rock Eng* 1993;26(1):1–27 <https://doi.org/10.1007/BF01019867>.
- [77] Rutqvist J, Kim HM, Ryu DW, Synn JH, Song WK. Modeling of coupled thermo-dynamic and geomechanical performance of underground compressed air energy storage in lined rock caverns. *Int J Rock Mech Min Sci* 2012;52:71–81 <https://doi.org/10.1016/j.ijrmms.2012.02.010>.
- [78] Terashita F, Takagi S, Kohjiya S, Naito Y. Airtight butyl rubber under high pressures in the storage tank of CAES-G/T system power plant. *J Appl Polym Sci* 2005;95:173–7 <https://doi.org/10.1002/app.20815>.
- [79] Zohuri B. Hybrid energy systems. Driving reliable renewable sources of energy storage. Cham: Springer; 2018 [http://doi.org/10.1007/978-3-319-70721-1\\_8](http://doi.org/10.1007/978-3-319-70721-1_8).
- [80] Perazzelli P, Agnostou G. Design issues for compressed air energy storage in sealed underground cavities. *J Rock Mech Geotech Eng* 2016;8(3):314–28 <https://doi.org/10.1016/j.jrmge.2015.09.006>.
- [81] Liu C, Xu Y, Hu S, Chen H. Techno-economic analysis of compressed air energy storage power plant. *Energy Storage Sci Technol* 2015;4:158–68.
- [82] Ordóñez A, Jardón S, Álvarez R, Andrés C, Pendas F. Hydrogeological definition and applicability of abandoned coal mines as water reservoirs. *J Environ Monit* 2012;14:2127–36 <https://dx.doi.org/10.1039/c2em11036a>.
- [83] Gandy CJ, Younger PL. Predicting groundwater rebound in the south yorkshire coalfield, UK. *Mine Water Environ* 2007;26:70–8 <https://doi.org/10.1007/s10230-007-0153-7>.
- [84] Álvarez R, Ordóñez A, De Miguel E, Loredó C. Prediction of the flooding of a mining reservoir in NW Spain. *J Environ Manag* 2016;184:219–28 <https://doi.org/10.1016/j.jenvman.2016.09.072>.
- [85] Younger PL, Banwart SA, Hedin RS. *Mine water, hydrology, pollution, remediation*. Dordrecht: Kluwer Academic Publishers; 2002.
- [86] Hall A, Scott JA, Shang H. Geothermal energy recovery from underground mines. *Renew Sustain Energy Rev* 2011;15:916–24 <https://doi.org/j.rser.2010.11.00>.
- [87] Burnside NM, Banks D, Boyce AJ. Sustainability of thermal energy production at the flooded mine workings of the former Caphouse Colliery, Yorkshire, United Kingdom. *Int J Coal Geol* 2016;164:85–91 <https://doi.org/10.1016/j.coal.2016.03.006>.
- [88] Preeve M, Younger PL. Can you take the heat? – geothermal energy in mining. *Min Technol* 2014;123:107–18 <https://doi.org/10.1179/1743286314Y.0000000058>.
- [89] Jardón S, Ordóñez A, Álvarez R, Cienfuegos P, Loredó J. Mine water for energy and water supply in the central Coal Basin of Asturias (Spain). *Mine Water Environ* 2013;32:139–51 <https://doi.org/10.1007/s10230-013-0224-x>.
- [90] Hamm V, Bazargan B. Modelling of fluid flow and heat transfer to assess the geothermal potential of a flooded coal mine in Lorraine, France. *Geothermics* 2010;39:177–86 <https://dx.doi.org/10.1016/j.geothermics.2010.03.004>.
- [91] Renz A, Rühaak W, Schätzl P, Diersch HJG. Numerical modelling of geothermal use of mine water: challenges and examples. *Mine Water Environ* 2009;28:2–14 <https://dx.doi.org/10.1007/s10230-008-0063-3>.
- [92] Raymond J, Therrien R. Low-temperature geothermal potential of the flooded gaspé mines, Québec, Canada. *Geothermics* 2007;37:189–210 <https://dx.doi.org/10.1016/j.geothermics.2007.10.001>.
- [93] Watzlaf GR, Ackman TE. Underground mine water for heating and cooling using geothermal heat pump systems. *Mine Water Environ* 2006;25:1–14 <https://dx.doi.org/10.1007/s10230-006-0103-9>.
- [94] Verhoeven R, Willems E, Harcouët-Menou V, De Boever E, Hiddes L, Veld POT, Demollin E. Minewater 2.0 project in Heerlen The Netherlands: transformation of a geothermal mine water pilot project into a full scale hybrid sustainable energy infrastructure for heating and cooling. *Energy Procedia* 2014;46:58–67 <https://dx.doi.org/10.1016/j.egypro.2014.01.158>.
- [95] Peralta E, Breede K, Falcone G. Geothermal heat recovery from abandoned mines: a systematic review of projects implemented worldwide and a methodology for screening new projects. *Environ Earth Sci* 2015;73:6783–95 <https://dx.doi.org/10.1007/s12665-015-4285-y>.
- [96] Banks D. Making the red one green: renewable heat from abandoned flooded mines. In: International Association of Hydrogeologists (Irish Group) editor. Proceedings of the 36th annual groundwater conference. Tullamore, Co. Offaly, Ireland. International Association of Hydrogeologists; 2016. p. 1–9.
- [97] Ochsner K. *Geothermal heat pumps. A guide to planning and installing*. London: Earthscan; 2008.
- [98] Andrés C, Ordóñez A, Álvarez R. Hydraulic and thermal modelling of an underground mining reservoir. *Mine Water Environ* 2017;36:24–33 <https://dx.doi.org/10.1007/s10230-015-0365-1>.
- [99] Wolkersdorfer C. *Water management at abandoned flooded underground mines: fundamentals, tracer test, modelling, water treatment*. Heidelberg, Germany: Springer; 2008.
- [100] Loredó C, Roqueñí N, Ordóñez A. Modelling flow and heat transfer in flooded mines for geothermal energy use: a review. *Int J Coal Geol* 2016;164:115–22 <https://dx.doi.org/10.1016/j.coal.2016.04.013>.
- [101] Loredó C, Ordóñez A, García-Ordiales E, Álvarez R, Roqueñí N, Cienfuegos P, Peña A, Burnside NM. Hydrochemical characterization of a mine water geothermal energy resource in NW Spain. *Sci Total Environ* 2017;576:59–69 <https://dx.doi.org/10.1016/j.scitotenv.2016.10.084>.
- [102] Mueller SC, Sandner PG, Welpe IM. Monitoring innovation in electrochemical energy storage technologies: a patent-based approach. *Appl Energy* 2015;137:537–44 <https://dx.doi.org/10.1016/j.apenergy.2014.06.082>.
- [103] Kucukali S. Finding the most suitable existing hydropower reservoirs for the development of pumped-storage schemes: an integrated approach. *Renew Sustain Energy Rev* 2014;37:502–8 <https://dx.doi.org/10.1016/j.rser.2014.05.052>.
- [104] International Renewable Energy Agency. *Electricity storage and renewables. Cost and markets to 2030*. 2017 Available from: [https://www.irena.org/media/Files/IRENA/Agency/Publication/2017/Oct/IRENA\\_Electricity\\_Storage\\_Costs\\_2017.pdf](https://www.irena.org/media/Files/IRENA/Agency/Publication/2017/Oct/IRENA_Electricity_Storage_Costs_2017.pdf).
- [105] Schainker R. *Compressed air energy storage (CAES): scoping study for California*. Palo Alto, CA: Electric Power Research Institute; 2008.
- [106] U.S. Department of Energy. *Annual energy outlook 2010*. DOE/EIA-0484(2010). US energy information administration (EIA). 2019 Available from: <https://www>.

- [nrc.gov/docs/ML1111/ML111170385.pdf](http://nrc.gov/docs/ML1111/ML111170385.pdf).
- [10][7] Red Eléctrica de España (REE) (Spanish Electrical Grid). Series estadísticas nacionales. 2019 <https://www.ree.es/es/estadisticas-del-sistema-electrico-espanol/series-estadisticas/series-estadisticas-nacionales>, Accessed date: 4 March 2019.
- [108] Colmenero JR, Suárez-Ruiz I, Fernández-Suárez J, Barba P, Llorens T. Genesis and rank distribution of upper Carboniferous coal basins in the Cantabrian mountains, northern Spain. *Int J Coal Geol* 2008;76:187–204 <https://dx.doi.org/10.1016/j.coal.2008.08.004>.
- [109] Kaiser F. Steady state analyse of existing compressed air energy storage plants. *Proceedings of the power and energy student summit 2015*. Dortmund, Germany: Technische Universität Dortmund; 2015.
- [110] Yang C, Wang T, Li Y, Yang H, Li J, Qu D, Xu B, Yang Y, Daemen JJK. Feasibility analysis of using abandoned salt caverns for large-scale underground energy storage in China. *Appl Energy* 2015;137:467–81 <https://dx.doi.org/10.1016/j.apenergy.2014.07.048>.
- [111] European Commission. Atlas of geothermal resources in Europe. In: Hurter S, Haenel R, editors. Luxembourg: Publication No. EUR 17811; 2002. p. 270.