

Università degli Studi di Bologna

Scuola di ingegneria ed architettura

Corso di Laurea in Ingegneria Meccanica

**JOINING ADHESIVE TECHNOLOGY
FOR COMPOSITE LAMINATES**

D. Gallego Menéndez, Alejandro

Tutor: D. Zucchelli, Andrea

2014-2015

CONTENTS

INTRODUCTION.....	4
1. ADHESIVE BONDS.....	5
1.1. ADHESION AND COHESION.....	6
1.2. ADHESION THEORIES.....	7
1.2.1. MECHANICAL THEORY.....	7
1.2.2. DIFFUSION THEORY.....	7
1.2.3. ELECTRICAL THEORY.....	7
1.2.4. ADSORPTION THEORY.....	8
2. JOINT DESIGN.....	9
2.1 LOADS AND STRESSES.....	9
2.1.1. COMPRESSION.....	10
2.1.2. TRACTION.....	11
2.1.3. SHEAR, PEEL AND TEAR.....	11
2.1.4. TRANSIENT EFFORTS.....	13
2.1.5. STATIC AND PERMANENT EFFORTS.....	13
2.1.6. DYNAMIC EFFORTS.....	14
2.1.7. RESIDUAL STRESSES.....	15
2.2. COMMON ADHESIVE JOINTS.....	16
2.2.1. BUMPER JOINTS.....	17
2.2.2. OVERLAP ADHESIVE JOINTS.....	18
2.2.3. ADHESIVE JOINTS IN T.....	21
2.2.4. ADHESIVE JOINTS IN CORNER.....	22
2.3. FRACTURE MODES IN ADHESIVE JOINTS.....	23
3. ASPECTS TO CONSIDERER.....	26
3.1. SURFACE ENERGY.....	26
3.2. CONTACT ANGLE.....	27
3.3. THICKNESS.....	28

3.4. CURED.....	31
3.5. EFFECT OF MOISTURE.....	32
4. TYPES OF ADHESIVES.....	34
4.1. RIGID ADHESIVES.....	35
4.1.1. ANAEROBICS.....	35
4.1.2. CYANOACRYLATES.....	36
4.1.3. EPOXIES.....	37
4.2 TENACIOUS ADHESIVES.....	39
4.2.1. ACRYLICS.....	39
4.3. FLEXIBLE ADHESIVES.....	40
4.3.1. POLYURETHANES.....	40
4.3.2. SILICONES.....	41
5. SURFACE TREATMENTS.....	44
5.1. PASSIVE SURFACE TREATMENTS.....	45
5.1.1. DEGREASING.....	45
5.1.2. MECHANICAL ABRASION.....	45
5.1.3. ULTRASONIC BATHS.....	45
5.2. ACTIVE SURFACE TREATMENTS.....	46
5.2.1. CHEMICAL TREATMENTS.....	46
5.2.2. LOW PRESSURE PLASMA TREATMENT.....	46
5.2.3. FLAME TREATMENT.....	46
5.2.4. CORONA DISCHARGE.....	47
5.2.5. PRIMERS.....	48
6. ADVANTAGES AND DISADVANTAGES OF ADHESIVES.....	51
6.1. ADVANTAGES.....	51
6.2. DISADVANTAGES.....	51
7. COMPOSITE MATERIALS.....	52
7.1. COMPOSITE LAMINATE.....	54
7.2. LAMINAR ORIENTATION.....	55
7.3. ADHESIVE BONDING FOR LAMINATE COMPOSITES.....	56
8. THEORICAL ASSUMPTIONS.....	58

9. LAMINATION THEORY.....	60
10. LAMINATE STACKING SEQUENCE.....	63
10.1. DESIGN OF A STACKING SEQUENCE.....	64
11. DESIGN OF LAMINATE COMPOSITES.....	65
12. DAMAGE AND FAILURE MODES.....	67
12.1. TENSION.....	67
12.1.1. MATRIX CRACKS.....	68
12.2. COMPRESSION.....	70
13. BUCKLING AND CRIPPLING.....	72
13.1. BUCKLING.....	72
13.2. POSTBUCKLING.....	76
13.3. CRIPPLING.....	76
14. GENERAL CONSIDERATIONS.....	78
14.1. RESIDUAL STRESSES AND STRAINS.....	78
14.2. THICKNESS EFFECTS.....	78
14.3. EDGE EFFECTS.....	79
14.4. EFFECTS OF TRANSVERSE TENSILE PROPERTIES IN UNIDIRECTIONAL TAPE.....	79
14.5. LAMINATE STACKING SEQUENCE EFFECTS.....	79
15. APPLICATIONS OF LAMINATED COMPOSITES.....	81
BIBLIOGRAPHY.....	85
RESUMEN CASTELLANO.....	92

Introduction

Throughout history, we can find numerous examples in which the human being has used the adhesives for the development of various activities; the Egyptians used this technology to link the leaves of the papyrus, the Babylonians used bituminous cement for building statues...

Since the eighteenth century, with the Industrial Revolution, to the present, the composite materials have become very important. Its development has been driven mainly by its good resistance to high loads, durability and for allowing to join materials of different nature.

Today, the adhesive bonds have multiple engineering applications that are becoming an ideal choice in the automotive, aerospace and shipbuilding sectors, increasing their use against mechanical joints, thanks to the advantages offered, among which we highlight:

- Uniform tension distribution
- Ability to thermal and electrical insulation
- Less manufacturing cost
- Absence of corrosion problems
- Elimination of welds
- Possibility of joining materials of different nature
- Less structural weight

The continued development of this technology will get mechanisms with better mechanical properties that today offer us.

Chapter 1: Adhesive bonds

The adhesive bonds in composite materials, are a process in which an adhesive is applied between the surfaces of the material or materials, both being joined after the adhesive has cured.

In this kind of structures we can distinguish two parts:

- The Adhesive: substance that we applied between the surfaces of materials to get a union.
- The Substrates: The materials we want to unite through the adhesive.

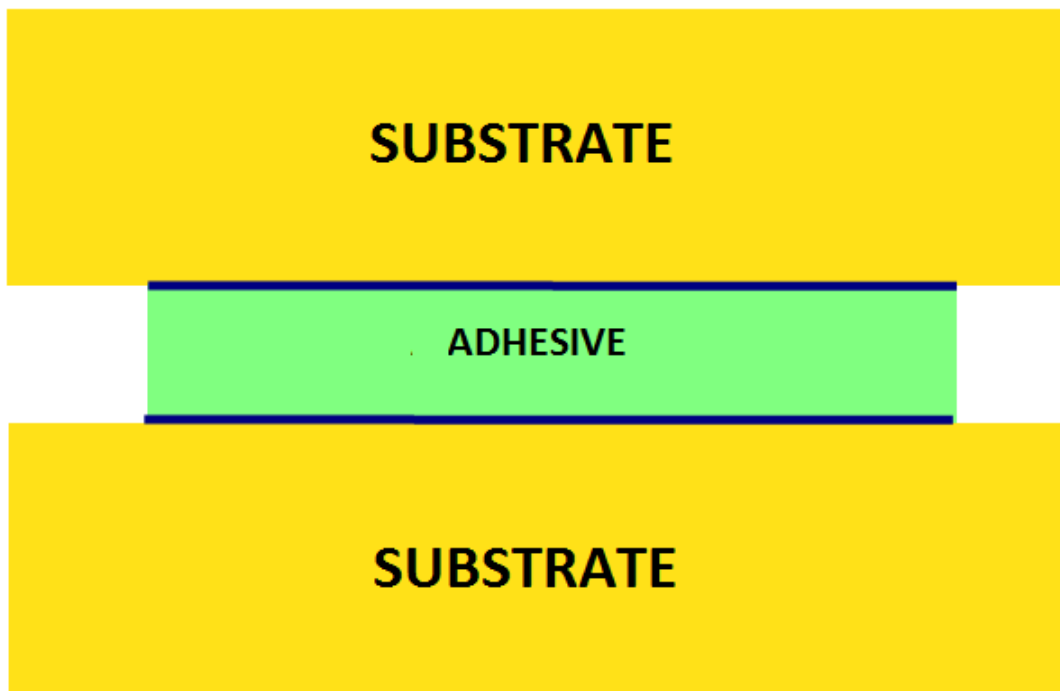

Figure 1.1- Basic scheme of an adhesive bond.

1.1. ADHESION AND COHESION

Adhesion is the state or phenomenon whereby two surfaces or different materials are joined by the action of forces of attraction and absorption. The maximum adhesion is obtained when the adhesive and the substrate are in intimate contact, that is, when the adhesive is able to fully penetrate the roughness and wet all surfaces.

As can be seen, the adhesion phenomenon depends mainly on the intermolecular contact (wetting) and the surface state of the substrate. For a given surface tension of the adhesive, wetting depends on the surface energy of the substrate (the higher surface energy the better wettability). Obviously, a contaminated or low energy surface will reduce the bond strength, so cleaning treatments are usually necessary.

Cohesion, however, is the force of attraction between adjacent particles which hold them together in the same substance. This force includes strong interatomic bonds of the polymeric chains and weak (Van Der Waals forces) of attraction between different chains.

Therefore, in all adhesive bonding, it is expected that maximum resistance is generated by the cohesive forces within the adhesive.

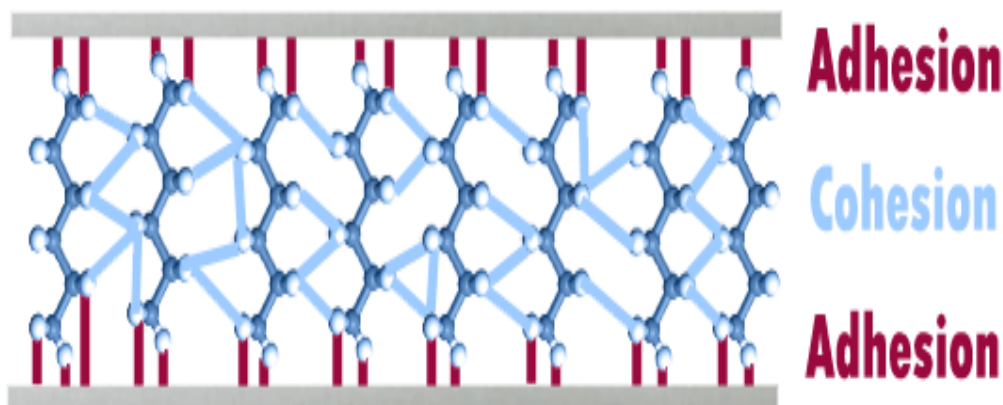

Figure 1.2- Phenomena of adhesion and cohesion in an adhesive bond.

1.2. ADHESION THEORIES

There are several theories to explain the phenomena of adhesion. This is because some theories can be applied to some cases but not others. At this point we will expose the different theories that explain this binding mechanism:

1.2.1. Mechanical theory

According to this theory, the union is due to the anchoring of the adhesive in the pores and roughness surface of substrate. During the process, the adhesive will be filling the surface cavities of the substrate. When it hardens, both substrates are joined together. Therefore, the roughness and porosity are important factors in the adhesion process. Sometimes surface treatments are needed to improve the surface conditions of the substrates. It is necessary to ensure good wettability of the substrate by the adhesive, because the non-covered cavities can be areas of bond failure.

1.2.2. Diffusion theory

This theory is used to explain the adhesion between polymers. The adhesion would have place due to the interdiffusion of the molecules on the surface planes, leading to the creation of an area of adhesive-substrate transition. Within this mechanism we find the self-adhesion, adhesion of compatible polymers and the thermoplastic or solvent welding.

1.2.3. Electrical theory

According to this theory, adhesion occurs due to electrostatic forces produced by the existence of an electrical double layer that forms when two materials of different nature are contacted. This theory can only be applied to very specific cases.

1.2.4. Adsorption theory

It defends the idea that adherence occurs as a result of contact between two materials and surface forces generated at the interface. These forces have the name of secondary forces or Van Der Waals force.

The process in which the adhesive and substrate are contacted is called wetting. When the surface tension of the adhesive is less than the surface energy of the solid, this is capable of wetting the substrate surface with a lower contact angle of 90° .

Chapter 2: Joint design

The joint design is considered the most important factor to achieve the maximum performance of the adhesive chosen. To do this, the adhesive bonds should be designed so that the adhesive works mainly subjected to shear stresses. The normal stresses, tension and compression, may be acceptable, but any deviation in the line of application may cause the presence of bending moments, subjecting the adhesive to unfavorable stresses of peel and tear.

In general, to achieve a good performance the set must be designed based on general principles and taking into account a number of general factors:

- Most of the paste area should contribute to the bond strength.
- The Design must comply the limits of application of the adhesive (depth of curing, gap filling, shelf life, etc.).
- The Union should be designed so that the adhesive works in the direction of maximum strength and reduce stress concentrations.
- The glued area should be as large as possible, within certain limits. An excessive increase of the area can reduce the resistance of the union.
- The adhesive must be able to transmit the expected loads.
- The physical and chemical properties of the adhesive must be compatible with the substrate.
- The fatigue strength of the adhesive as well as its ability to absorb energy must be previously known.

2.1. LOADS AND STRESSES

In practice, the most common failures are due to the ignorance of the efforts that will support the adhesive bond during the service. Therefore, it is essential to know the extent and nature of the stresses which will be submitted the set before deciding the adhesive type that we will use.

The mechanical loads that will be applied on the assemblies will generate tensile, compression, shear, peel and tear efforts, being the last two the most unfavorable for this type of structures. We can also find certain situations where tensions generated by the appearance of secondary phenomena with temperature changes can occur.

Normally, these tensions are not shown individually, but usually are presented combined with each other.

Schematically, the solicitations to which the adhesive bonds will be subjected can be:

2.1.1. Compression

Compressive stresses are generated by perpendicular forces to the joint plane, producing a volume reduction and a shortening of the body in the direction in which they are applied. Compression loads produce a very uniform stress distribution along the bond line, all the areas of the bond line endure the same load. The incident forces ratio and joint area are calculated to calculate their tensions.

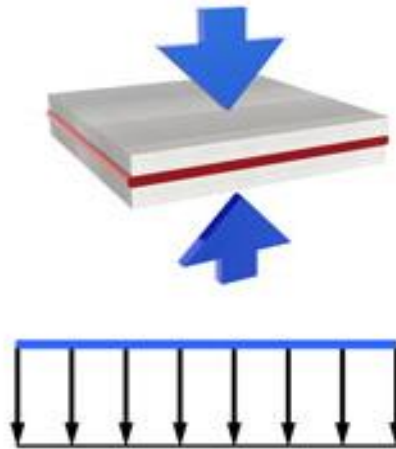

Figure 2.1- Compressive stress and its distribution on the bond line.

2.1.2 Traction

These stresses are caused by forces acting perpendicular to the bond line, tending to elongate the test piece. Tensile stresses are acceptable if the applied forces are uniformly distributed throughout the section. However, if the applied load is concentrated at one point of the surface can be dangerous, since the occurrence of bending moments, leading to the generation of peeling efforts, and therefore to a nonuniform distribution of tensions.

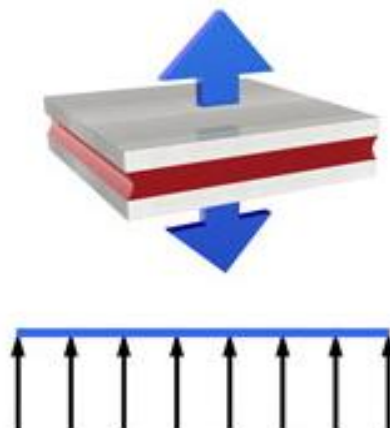

Figure 2.2- Tensile stress and its distribution on the bond line.

2.1.3. Shear, peel and tear

Normally there aren't many applications in which the adhesive bonds are subject to tensile and compression, being most common in practice to find shear, peeling and tearing loads.

The shear stresses are produced by the application of external parallel forces to the connecting line.

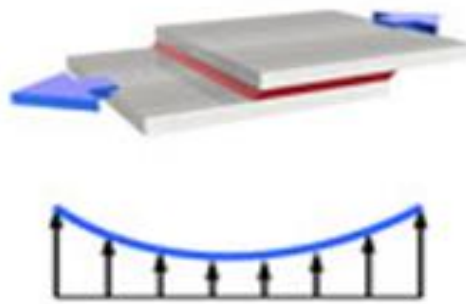

Figure 2.3- Shear stress and its distribution on the bond line.

Peeling efforts are very dangerous in the adhesive bonds and occur when one substrate is more flexible than the other. By applying a high tensile stress on one end of the bond line a bending moment is generated, which subjects the adhesive to a peeling stress. The action of this stress affects a very thin line at the edge of the union, while in the rest of the joint tension isn't almost detected.

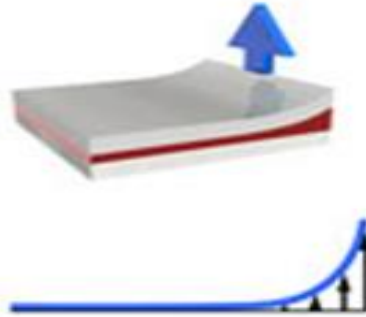

Figure 2.4- peel stress and its distribution on the bond line.

Tear efforts occur in a similar way to peeling. By applying a tensile stress, one end of the board will be affected while the rest remains almost without tension. The difference with the peeling is that in this case the substrate is not deformed.

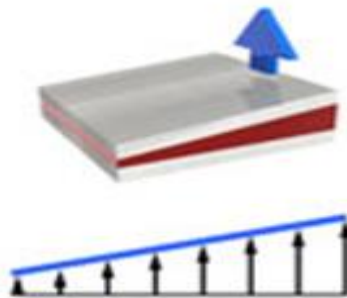

Figure 2.5- Tear stress and its distribution on the bond line.

The application of this type of stresses produces a less uniform and more difficult to calculate distribution.

The shear stresses are distributed over the bond line producing stress concentrations at both ends, while in peeling and tear efforts most of the stress is concentrated at only one end.

2.1.4. Transient efforts

These efforts are due to a unique increase of the effort to the maximum load. Although they don't typically appear in practice, these efforts are important in determining the nominal strengths of adhesives.

2.1.5. Static or permanent efforts

These are constant efforts over a period of time.

If a stress acts in one direction for an extended period of time, it generates a relative displacement, weak but constant, of the binding elements without requiring an increase in the applied force. This movement will continue progressing until the failure of the structure occurs.

This phenomenon is called fluency and essentially depends on temperature.

Because of this, in the inside of the adhesive bond the strength of cohesion will be reduced gradually until it reaches a moment in which the molecules begin to slide over each other. This will produce a plastic deformation difficult to appreciate if the measure devices are not available.

The fluency phenomenon could be reduced to acceptable limits with an appropriate design or even eliminated if we correctly choose the adhesives.

2.1.6. Dynamic efforts

There are two types of dynamic solicitation cycles:

- Regular (vibratory)
- Irregular (impacts)

When we have a regular alternative effort the adhesive has to absorb the deformation energy. This can cause a progressive cracking that result in the fracture of the material. This phenomenon is called fatigue.

In the case of having repetitive efforts regularly accompanied by abrupt cycles, the calculation of the adhesive bond is complicated. This is because the evolution of the efforts is not known exactly and the reaction of the adhesive will depend on these sudden changes. In such situations, comparative trials must be done in which we take into account the application expected or the resistance calculations based on known values of the permanent resistance (by applying safety factors that allows us to get closer to the real situation).

In the study of any adhesive bond subjected to dynamic stresses it is essential to know the fatigue resistance properties of the adhesive.

For irregular efforts, apart from possible deformations suffered by the substrates, the impact generates a compression wave transmitted by the different parts of the adhesive bond depending on the energy absorption capacity of the substrate. Therefore, the consequences on a particular union, subjected to these efforts, are directly dependent on the nature of the materials composing the substrates.

This way, when designing an adhesive bond where irregular efforts are going to be applied, we must take into account the impact absorption capacity of both, the substrate and the adhesive. Since in the case of having a substrate that poorly absorbs the impacts, the vibrations produced will be transmitted to the adhesive, which should present a good absorption of energy capacity to avoid the failure of the structure, and vice versa.

2.1.7. Residual stresses

When we have an adhesive bond in which the adhesive is cured at a temperature above the ambient, additional internal stresses can be generated (residual stresses) caused by thermal

deformations. These deformations are caused by differences in the expansion coefficients of both materials (adhesive and substrate).

These residual stresses are difficult to calculate analytically, therefore, photoelastic methods are used for their study.

The use of a more flexible adhesive, the use of a greater thickness of the adhesive layer, the use of a lower temperature and the use of a longer and slower time of cooling can end the problem.

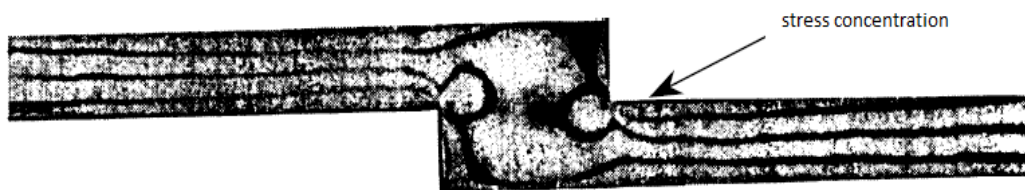

Figure 2.6- Internal tensions of an adhesive bond measured by photoelastic cells.

2.2. Common adhesive joints

The ideal adhesive joint is when the adhesive is demanded in the direction of the greater stress concentration, reducing the presence of undesirable peeling and tearing efforts, and thus providing a good stress transmission and distribution along the whole system. This can be achieved with an appropriate design.

We can find various types of adhesive joints, but probably the most common ones are the following:

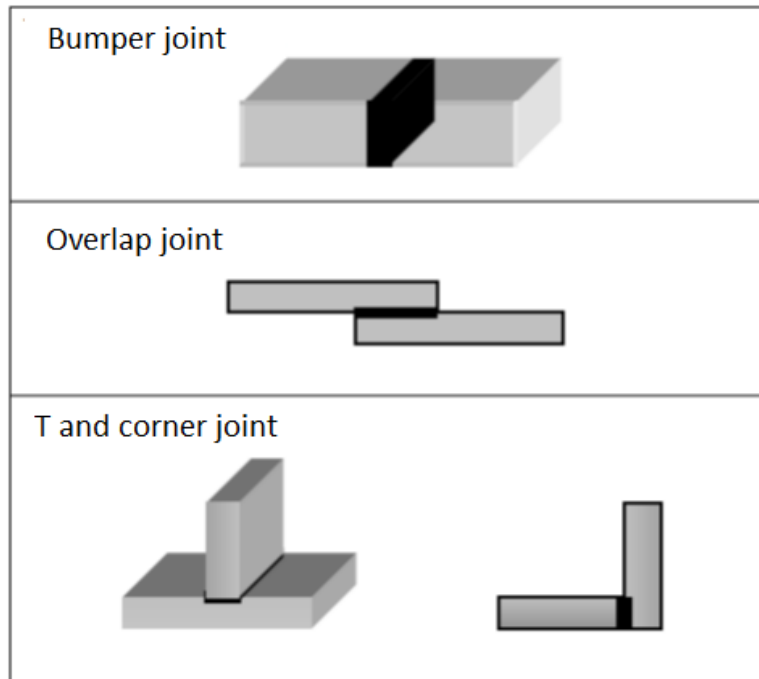

Figure 2.7- Typical adhesive joints.

2.2.1 Bumper joints

This type of joint shows a good tensile and compression resistance. However, if the load is applied perpendicularly to the axis, bending moments that cause tearing of the union can be generated.

Bonding in this type of joints can be improved using complementary techniques that increase the contact area and in turn the tearing resistance:

- By bond bevelling
- By using joint covers

Due to design considerations, beveling is often used as a method to increase bond strength.

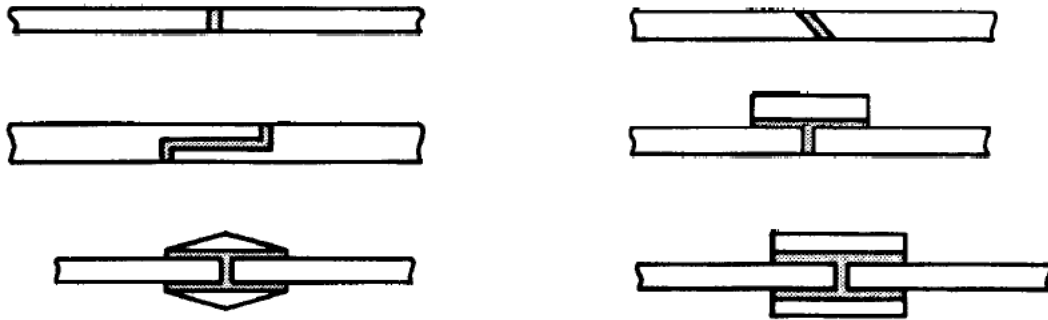

Figure 2.8- Adhesive bumper joints

In this type of joints, we can also find tubular bonding, they are currently used when the application requires axial and torsional loads. These joints may exhibit different designs due to the different geometry of the tubes.

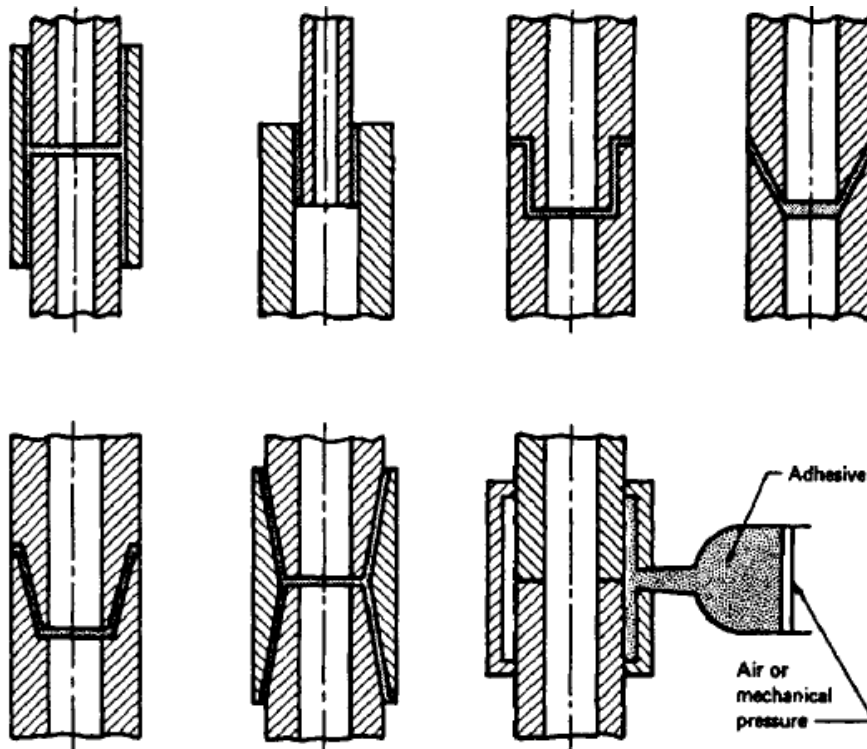

Figure 2.9- Tubular adhesive joints.

2.2.2. Overlap adhesive joints

This is the type of joints more widely used due to their easy assemblage which allows the bonding of low thicknesses materials. Moreover, against axial loads, overlap joints demand shear bonding, which is very convenient because, as above mentioned, the adhesive bonds show a great resistance to shear stresses. As a general recommendation, overlapping lengths should not exceed 25-30 mm

The shear resistance in this type of joints is directly proportional to the overlap width. However, due to the fact that the stresses concentrate at the end of the bonding line, the relationship between the overlap length and the shear resistance is not lineal, independently that an increase is observed.

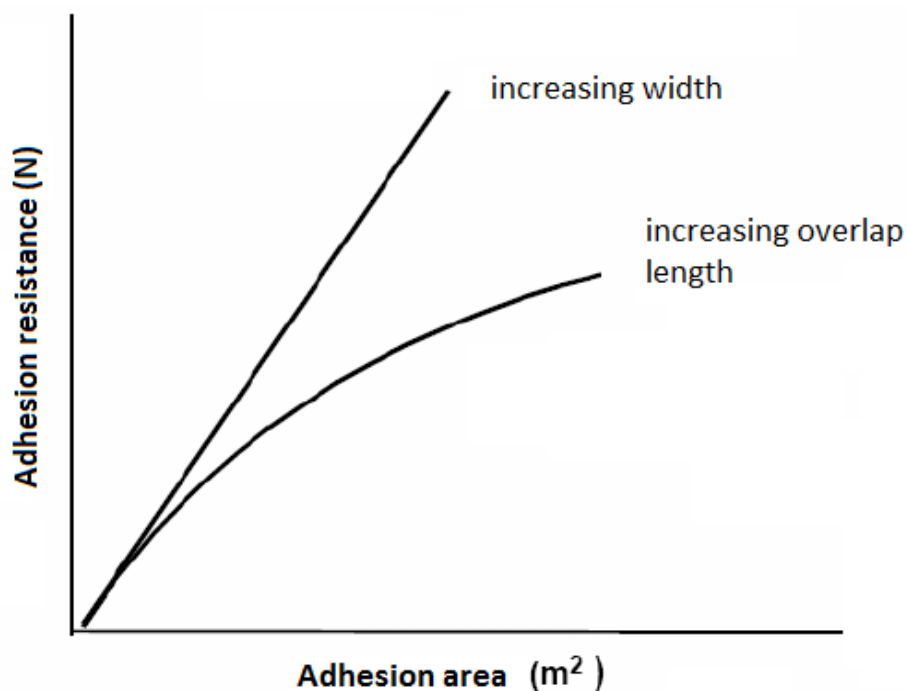

Figure 2.10- Resistance variation of an adhesive bond by increasing the width and length of overlap.

Still, these joints also support stress concentrations caused by loads misalignment, producing bending moments on the substrates that distort bonding and generate tearing.

There are a series of methods to increase overlap joints resistance, which introduce design variations in both, the bonding zones and the thicknesses of the substrates:

- Joint design with aligned stresses.
- Substrates stiffening, to avoid tearing stresses
- Make flexible the edges of the substrates in the joining area for a better adapt and a reduction of peeling efforts. This can be achieved by a beveled edge.

As we saw above, the length and width of overlapping influence the bond strength, but they are not the only ones. The load from a substrate which exceeds its elastic limit depends on rigidity and thickness.

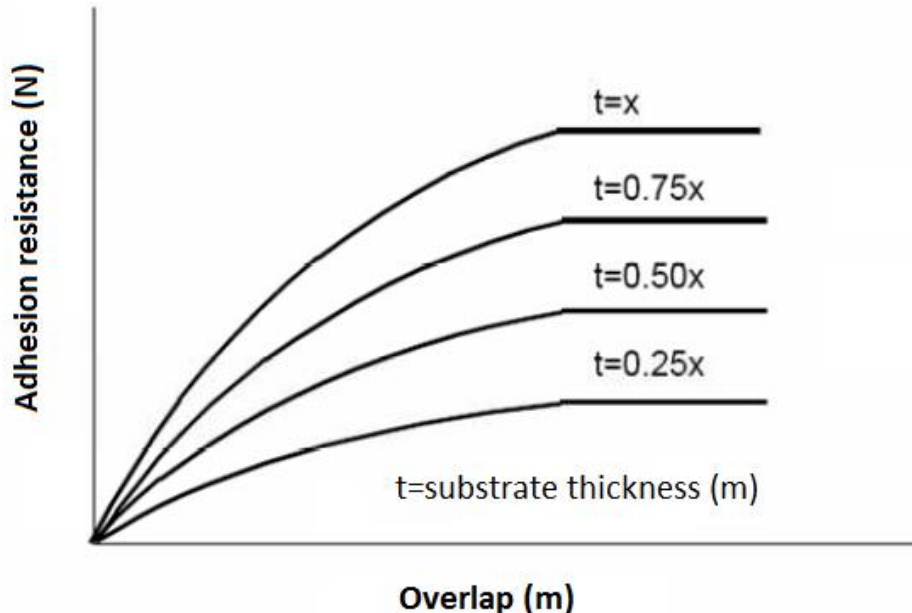

Figure 2.11- Resistance variation of the adhesive bond against the overlapping of different thicknesses

Brunie and Houwink evaluated the relationship between thickness, overlapping and tension, and define as joint factor the ratio of the square root of the thickness between the overlap length.

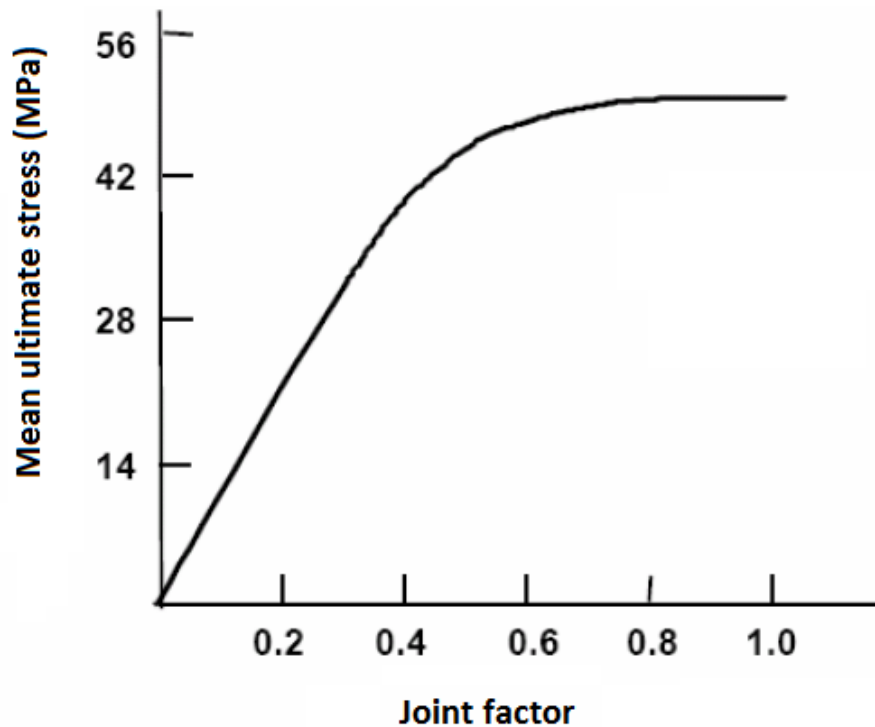

Figure 2.12- Effect of the joint factor in the resistance of the adhesive bonds.

Consequently, stiffening can be achieved by increasing the thickness of the substrate at the edges of the bonding zone, taking into account that the increase in the final weight should not be excessive.

Some of these possible solutions include:





SIMPLE JOINTS	JOINTS REINFORCED
<p data-bbox="293 353 555 383">simple overlap joint</p> 	<p data-bbox="831 360 1098 389">Double overlap joint</p> 
	<p data-bbox="826 501 1118 530">Bevelling overlap joint</p> 
	<p data-bbox="831 636 1002 665">Overlap joint</p> 
	<p data-bbox="826 770 1086 837">Mechanized overlap joint</p> 

Figure 2.13- Overlap adhesive joints

In some cases, due to design limitations, the joint is subjected to great tearing stresses, making the use of techniques which avoid the movement of the edges of the joint necessary. These techniques include: an increase of the stiffness or the area of the adhesive at the edge of the substrate, generating a wrinkle which favors a mechanical anchorage; or the development of a rivet or welding point on the edge.

2.2.3. Adhesive joints in T

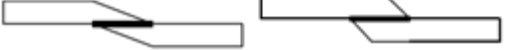
Joints in T show low resistance to transversal stresses because they generate tearing and peeling stresses. Compression stresses are more dangerous than bending ones, as they can produce the buckling of the sheet and the occurrence of bending moments on it.

Normally, to improve the strength of such unions, brackets and design elements that increase the bonding area and the stiffness are used, in order to avoid bending stresses.

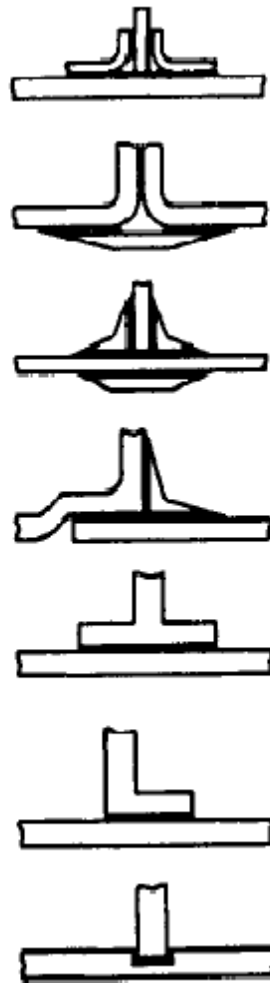

Figure 2.14 - Adhesive bonding in T.

2.2.4. Adhesive joints in corner

Similarly to previous, this type of joints shows very low resistance to transversal and compression stresses.

The use of reinforcement elements (brackets or auxiliary parts fitted to) significantly improves the resistance of these joints.



Figure 2.15 - Adhesive bonding in corner.

2.3. FRACTURE MODES IN ADHESIVE JOINTS

An adhesive joint resistance depends first, of the bonding between the substrate and the adhesive (adhesion) and the internal forces of the adhesive itself (cohesion).

The bonding resistance can be estimated by a break test. The possible failures in an adhesive joint are:

- Cohesive failure, when the adhesive breaks.
- Adhesive failure, when the separation occurs at the adhesive-substrate interface.
- Substrate failure, when the substrate breaks before than the adhesive or the substrate-adhesive interface.

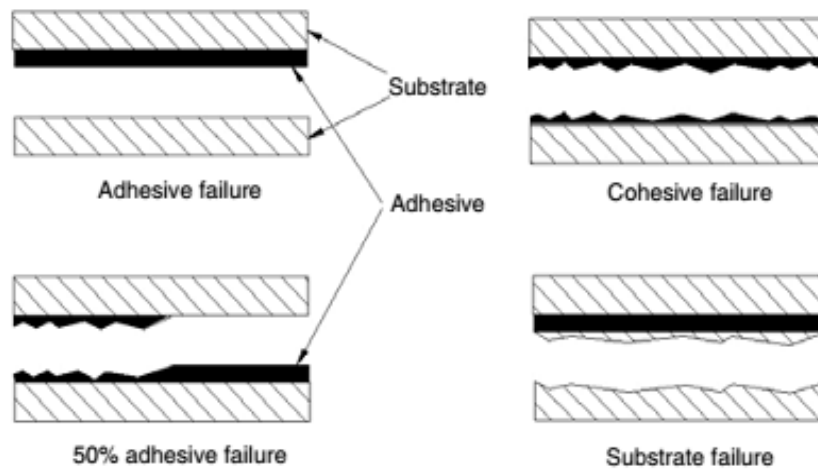

Figure 2.16- Types of failures in the adhesive bonds.

When designing an adhesive joint, it is always intended to avoid an adhesive failure, or what is the same, to avoid interface failure.

The failure type of an adhesive bond is unpredictable, because the adhesion forces magnitude depends of a great number of factors difficult to completely control. However, the mechanical characteristics of the adhesive can be known and consequently, the cohesive failure loads under different stresses.

Substrate failure occurs due to the oversizing of the bonding zone. Therefore, it is considered a design flaw, because an amount of adhesive has been employed exceeding the necessary mechanical.

The adhesive joints failure can be produced by very different reasons, among them we can point:

- The presence of cracks or voids, as well as the development of residual stresses that can concentrate the stresses.
- The application of dynamic stresses that may favor the fatigue failure.
- Fluency.
- A bad compatibility between the adhesive and the substrate.

- A bad stresses transmission.
- A bad sizing of the whole system
- Application of normal stresses that may favor peeling or tearing in the adhesive.

Chapter 3: Aspects to consider

To achieve a successful union we must take into account a number of parameters when making the design of the adhesive bond. Some of these factors to keep in mind are the following:

- The surface energy of both, the adhesive and the substrate to ensure a good adhesion.
- The curing characteristics of the adhesive.
- The size of the thickness of the bond line, so as to ensure a good transmission of the stresses.
- The effects that the adhesive bonds may be exposed to by the action of environmental agents, in particular by the presence of moisture in the environment.

3.1. SURFACE ENERGY

The surface energy plays an important role in the interactions between the adhesive and the substrate to generate a good bonding.

The surface energy can be defined as the energy required to break the intermolecular bonds resulting in a surface. In the case of liquids, this surface energy has the same value as the surface tension, and it is due to all intermolecular forces acting in each molecule.

As shown in Figure 3.1, the molecules inside the liquid are subjected to cohesive forces which in average are zero. However, the molecules at the surface are not completely surrounded by other molecules, interacting more strongly with those in their vicinity. This creates a film with a certain tension, which makes difficult to move an object through the surface.

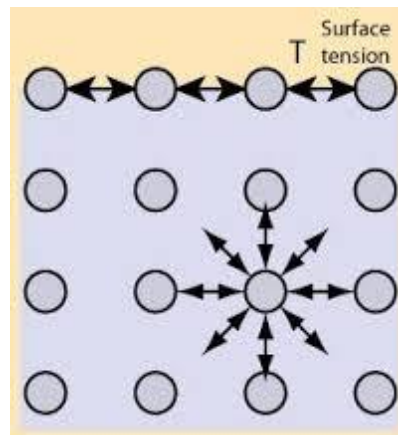

Figure 3.1- Basic diagram of the surface tension of a liquid

The substrates with a higher surface energy than the surface tension of the adhesive attract the molecules due to the adhesive forces between both materials. As a result of that, the adhesive expands along the substrate surface and wetting is favoured.

The presence of foreign substances (contaminants) may reduce the surface energy of the substrates, and it is why cleaning treatments become necessary.

If the substrates show surface energies substantially lower than the surface tension of the adhesive, surface treatments which improve the value of the surface energy can be applied, thus improving the wetting behaviour.

3.2. CONTACT ANGLE

Another important factor when dealing with the surface wetting of a substrate is the contact angle. It can be defined as the angle which forms a drop of the adhesive with the surface of the substrate. Its value is indicative of the degree of wetting of the liquid to the solid (adhesive and substrate in our case) and also provides information about certain surface characteristics, such as the surface energy of the substrate.

The value of the contact angle mainly depends of the chemical interaction between the surfaces of the two materials. The adhesive will wet the substrate when the contact angle is below 90° .

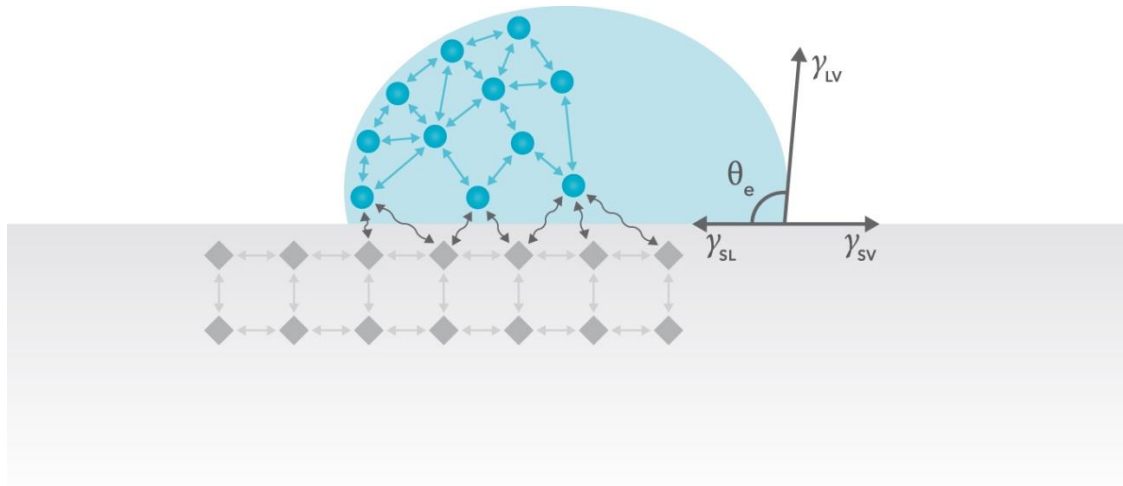

Figure 3.2- Contact angle between the surface of the adhesive and substrate

3.3. THICKNESS

Another aspect to consider when designing an adhesive bond is the distribution and size of the thickness of the adhesive layer.

Thickness distribution along the bond line is a very important factor to obtain good adhesive properties. The use of a nonuniform adhesive generates a high peel stress and reduces the adhesion force, favoring the structure failure, and deteriorating the transmission of forces through the womb of the adhesive.

Normally, it is assumed that the thicker a layer is the greater its resistance will be. However, the application of a thick layer can lead to the generation of certain disadvantages, among which we highlight:

- Increased risk of generation of air bubbles or elements that may serve as stress concentrators, favoring the adhesive fracture
- Variation of curing properties producing internal tensions.
- Increased tensions at the ends of the adhesive.

However, excessively thin layers can prejudice the binding by not covering all the voids or superficial undulations of the substrates, generating areas prone to separation.

To avoid these situations, we have a number of methods that allow us to control the thickness of the bond line. These systems should not produce voids in the adhesive that prejudice the binding of the set. Among them, we include:

- Mechanical apparatus
- Fine spacers of wire or stainless steel placed between the adherents: is important that these spacers employed for controlling the thickness are well located within the bonding area, away from the ends of the sample where the regions of highest stress concentration are.
- Glass spheres: The thickness of the connection band will have the size of the diameter of these mixed with the adhesive before application. The distribution of the spheres should be uniform and should not exceed 1% by mass of adhesive. An adhesive with a high percentage of spheres will produce an excessively rigid blend, while if the percentage is very small the thickness will lose uniformity along bondline.
- Glass fibers distributed along the adhesive
- Microfibers mixed with the adhesive

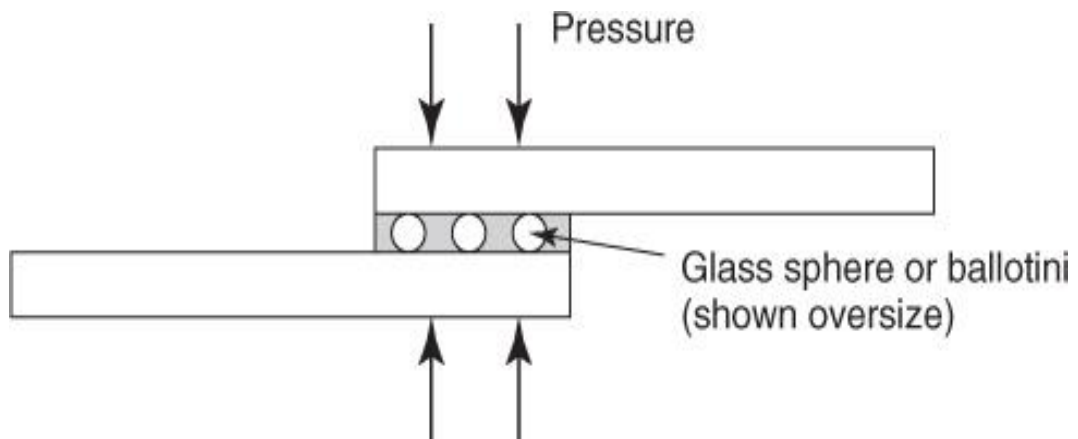

Figure 3.3- Control of adhesive thickness by the use of glass spheres.

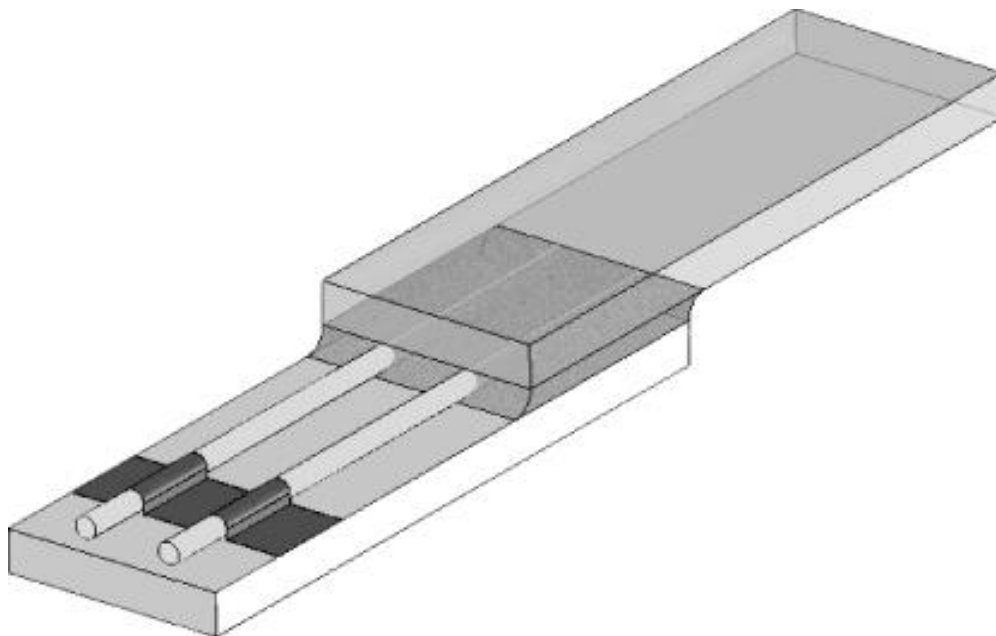

Figure 3.4- Control of adhesive thickness by the use of calibrated wires.

As we discussed in previous chapters, due to the loads which may be subject these structures, stress concentrations can occur at the ends of the bond line. As shown in the figure, we can increase the stiffness in these areas by increasing its thickness.

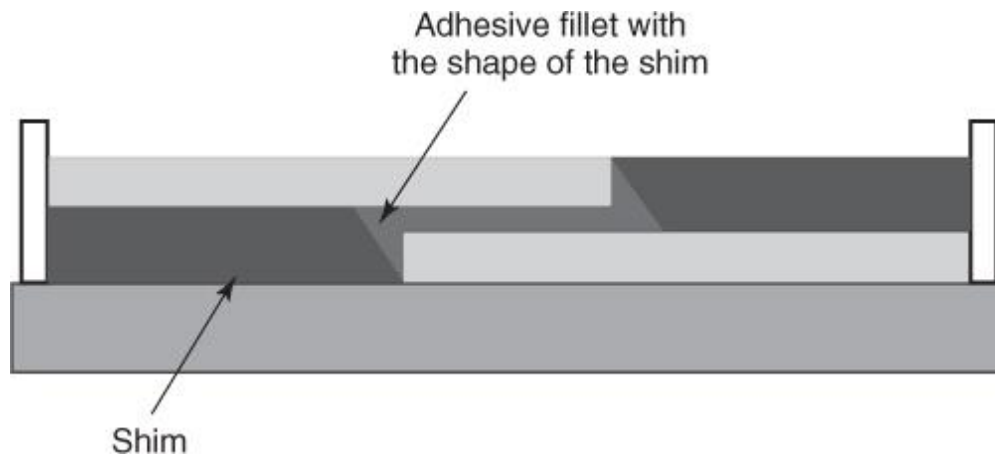

Figure 3.5- Control of adhesive thickness by the use of shims

Once the adhesive is dried, we should measure the resulting thickness to check that fits in our design. We highlight, among others, the following methods to obtain the thickness of the bond line:

- Measure the thickness of the whole, with the help of a micrometer, and subtracting the thickness (premeasured) of the substrates.
- Directly measuring the thickness with the aid of a microscope

3.4. CURED

The parameters influencing good curing of adhesive bonds are: pressure, curing time and temperature.

As we mentioned, the adhesion is a surface phenomenon that requires good wetting of the surface of the substrate by the adhesive. A good pressure during curing can improve wetting, helping the adhesive to reach voids and unevenness on the surface of substrates and providing greater control of the thickness of the bond line.

With excessively long curing times it may happen that the adhesive dries before getting correctly and completely wet the substrate surface, resulting in future failures. If, however, we have excessively short times, there is a risk of leakage of the adhesive as well as a greater probability that voids are generated within it that can serve as stress concentrators triggering the breakage of the material

In the case of the temperature, if we have parts of the same material and thickness, all joints will be warmed at equivalent speeds. However, it is sometimes necessary to adjust the curing process to control the temperature cycles in which the parts to be joined have different masses or thermal conductivities, that is to say, the curing time for each assembly should be adjusted so that the adhesive mass in contact with the slower heating portion achieves proper curing.

Generally, in a process in which thick and thin parts are joined, or if the pieces have very different conductivities, the temperature reached by the adhesive in the thickest/lower conductivity piece can be much lower than that achieved by the adhesive in the thinner/higher conductivity piece. In extreme cases, the temperature may rise sufficiently to cause degradation of the adhesive or of the substrates.

Many adhesives cure at room temperature, which may involve excessively long curing times. This can be inconvenient, so in some situations heat is applied to accelerate the process. However, this process can generate different properties to those obtained with initial conditions. To reduce these variations, both situations should alternate; performing a first cure at ambient temperature followed by another at higher temperature.

Temperature and time are closely related. If the heating speed is too quick, the curing time will be too small, and vice versa, leading to the aforementioned faults.

3.5 EFFECT OF MOISTURE

Environmental factors can also directly affect the resistance of the adhesive bonds. Water is one of the agents that can impair the most the durability of the joints, as their molecules are highly polar and permeable to most polymers. Since most of the adhesive bonds are exposed to the action of water (liquid or gas), when the relative humidity reaches a value high enough it is impossible to avoid the diffusion into the adhesive. In this way, the adhesives susceptible to moisture become more sensitive when loads are acting on them.

At low concentrations moisture can act as a plasticizer which softens the adhesive. This effect produces a minimum impact resistance and can be reset with drying. However, as the concentration of water molecules begins to increase, irreversible changes that may affect the adhesion to the substrates and particularly to the interface between them may occur.

The entrance of water into the adhesive joint can occur by the following mechanisms:

- Dissemination through the adhesive from the outer edges in contact with moisture.
- Transport along the adhesive/adherents interfaces.
- Dissemination through permeable adherents such as composite materials of polymeric matrix.
- Migration by microcracked areas of the adhesive.

The consequences caused by water entering the joint may include the following:

- Plastification of the adhesive with loss of resistance strength.
- Change in the adhesive properties as a result of microcracking and hydrolysis.
- Swelling and generation of residual stresses in the joint.
- Attack to the adhesive/substrate interface by moving the adhesive or because of a direct reaction of water with the adherent.

Chapter 4: Types of adhesives

We can find a lot of adhesives on the market today. In order to classify them, we can order them according to their physical properties or the type of mixture:

Depending on their physical properties:

- Rigid adhesives: junctions provide high rigidity, despite of low resistance in dynamic applications or peel efforts, there are more tenacious formulations for all that allow them to improve their response to these situations.
- Tenacious adhesives: They have excellent performance in both, dynamic applications and when applied loads generate peel stress and/or tearing.
- Flexible adhesives: The main function of these adhesives is sealing. However, they are also used in structural joints extending the application surface to increase the rigidity of the assembly.

Depending on the type of mixture:

- Bicomponent mixed adhesives: In this category are those adhesives that require a premix before being applied on the substrate surface. After mixing the two components, the adhesive has a limited lifetime.
- Bicomponent unmixed adhesives: On one surface of the substrate the adhesive is applied and over the other, although in a smaller amount, an activator. The adhesive cures by the reaction of two components joining both surfaces. As can be seen it does not require a premix for curing the adhesive.

- Monocomponent adhesives: In this group is not required any mixture and the adhesive is the only component applied to the surface of the substrates.

4.1. RIGID ADHESIVES

4.1.1. Anaerobics

Anaerobics are bicomponent adhesives which react in the absence of air or in the presence of metal ions. After the polymerization does not dissolve or melt with temperature or solvent.

These substances are perfect for applications in which the shear is the predominant effort. Generally they have low tensile strength so as to impact and peel.

This type of adhesive is suitable in metal assemblies where the presence of ions in the substrate surface promotes the polymerization process. When the surfaces of the substrates are passive (aluminum, nickel, zinc, gold, silver, etc.) using a chemical agent is required to cover the absence of ions. This agent is called activator. With non-metallic substrates (plastics, glass, wood, ceramic, etc.) applying an activator it is also required, but the use of these products with different substrates to metals is not recommended.

Obviously cure times are greater in the case of non-metallic substrates. These types of adhesives may also be cured by heat, achieving complete polymerization between 120°C and 150°C heating for about 30 min. Both corrosion and surface dirt impede the contact of the adhesive with ions preventing the polymerization reaction to take place.

Advantages of anaerobic adhesives:

- Good chemical resistance
- Excellent resistance to shear and compression
- Fast curing times
- Do not requires large surface finishes

- Good temperature resistance (from -55°C to 149°C)
- Good resistance to traction and metallic loads

Disadvantages of anaerobic adhesives:

- Poor resistance to both tensile and peel
- Require the use of activators in the case of passive or non-metallic substrates.

These features make the anaerobic adhesives great for certain applications:

- Thread locking
- Flange sealing
- Retention of cylindrical parts
- Impregnation of metal pieces

4.1.2 Cyanoacrylates

Cyanoacrylates are single component adhesives which cure rapidly in the presence of humidity when they are imprisoned in a thin film between two surfaces.

In most cases, the substrates have humidity absorbed from their surfaces. Thereby, when a drop of cyanoacrylate is compressed and extended between two surfaces, the thin film comes into contact with the moisture absorbed in the surface (basics), resulting in a rapid initiation of polymerization. The smaller the adhesive film is the lower the curing time will be.

Polymerization for this type of adhesives does not occur fastly when we have acidic surfaces or with large gaps, yet the fixing speed is typically fast enough for the application of some kind of activator.

Advantages of cyanoacrylate adhesives:

- Easy application

- Low curing times
- Good chemical resistance
- Produces colorless adhesions
- Can be applied to different materials (metal, plastics, ceramics, wood, leather, glass, natural and synthetic rubber), and can also combine them.

Disadvantages of cyanoacrylate adhesives:

- Ability to looseness limited (usually 0.2mm)
- Low impact and peel resistance on metal substrates
- Low temperature resistance (maximum 80°C), but the most tenacious formulations can endure up to 120°C
- The blooming or blurring caused by the volatility of the monomer

These features make the anaerobic an ideal adhesive for certain applications:

- Automated assembly processes
- Glued of plastic parts (for example, the parts located in the passenger compartment of a car)
- In the electrical and electronics industry
- As curious applications we can emphasize its use in the unmasking of fingerprints by many police departments, as well as their use in the field of medical suture.

4.1.3 Epoxies

This type of adhesives can be found in two versions: as bicomponent plus activator and as mono component.

Two component epoxies have a good shelf life and require no refrigeration. This type of epoxies can be cured at room temperature but is generally necessary to apply high temperature to improve performance.

Furthermore, in the case of monocomponents its cooling is required and have a rather low useful life. Like the above, they require high curing temperatures.

Epoxies are quite sensitive to the surface conditions of the substrates and the mixing ratio. So, usually, surface treatments are necessary before applying the adhesive.

These products are generally applied by hand, except in the case of large volume productions, where automatic dispensing equipment are used to accomplish the mixture before application onto the surface, with the aim of preventing human error in the mixture and the application.

Advantages of epoxies:

- Good filling characteristics in large volumes
- High resistance to shear and traction
- Good chemical resistance
- Good characteristics for of joining rigid surfaces
- Though is dielectric and thermal insulator, can be modified to conduct both electricity and heat
- Resistance at temperatures up to 180°C (may reach 250°C in some formulations)
- Allows bonding substrates of various materials, even combined with each other

Disadvantages of epoxies:

- Troubles of absorption and diffusion of moisture within it
- Poor resistance to peel efforts and impact, which can be solved with more flexible formulations.
- Requires high curing temperatures
- High curing times
- Low life of mixture

Some areas of application of epoxies are:

- Aeronautical and electronic industry
- Construction industry (as additives for concrete and other construction elements)
- Production of composite materials

4.2 TENACIOUS ADHESIVES

4.2.1 Acrylics

The acrylics are bicomponent adhesives in which isn't necessary a completely homogeneous mixture of resin and activator. These types of adhesives are formulated for curing by the application of heat, by an activator, or even, in the case of industrial acrylic with light.

The light curing adhesives are normally used for large volumes in which capital investment for the development of the emission source of light is justified.

Advantages of acrylics:

- High temperature resistance (up to 180°)
- Versatile dosification
- Excellent hydrolytic resistance to aggressive environmental agents
- Minimal surface preparation needed or even zero in the case of metals and plastics
- Excellent price-performance ratio
- Good gap filling capacity (up to 3mm)
- Good physical structural properties and resistance against loads
- Cure times very short

- Allows the union of different materials (metal, wood, glass, plastic), even to each other.

Disadvantages of acrylics:

- Less adhesion to most elastomers
- Odor
- Low inflammation points

Some areas of application of acrylic adhesives can be:

- Solar heating panels
- Automotive industry
- Structural adhesion on ships and planes
- Brake Shoe adhesion to crowns
- Speaker magnets

4.3 FLEXIBLE ADHESIVES

4.3.1 Polyurethanes

Polyurethanes, like epoxies, can be found as bicomponents plus activator as well as monocomponents. These products are based on isocyanate chemistry, resulting from the reaction of an isocyanate with water or with a polyol or an amine in the case of the bicomponents.

The monocomponent polyurethanes polymerize from the outermost layer to the innermost by reaction with moisture, which limits the thickness of the adhesive, curing time increases and reduces its useful life, because as the outermost part of the adhesive is dried worsens the bond to the substrate. Sometimes the application of heat is required to accelerate the curing of the adhesive. Usually these adhesives are used as sealants.

The bicomponent polyurethanes have a wide range of curing times to meet different application requirements.

Polyurethanes wet badly the surfaces, and this requires the use of primers, which react with ambient moisture.

Advantages of polyurethanes:

- Allows bonding a wide range of substrates
- Remain flexible in a temperature range between -40°C and 80°C
- Good chemical resistance
- Can be painted
- Produces very mild odor
- Better resistance to peel than epoxies

Disadvantages of polyurethanes:

- Troubles of safety and hygiene during polymerization
- Primers needed
- Low resistance to UV radiation

Some areas of application of polyurethanes can be:

- Construction and reparation of ships, trailers, containers, doors and windows...
- Transportation and automotive
- Mechanical engineering and machines assembling
- Household appliances
- Ventilation systems

4.3.2 Silicones

Silicones are single component adhesives whose polymerization reaction generates byproducts that are often volatile. Silicones can be classified according to the type of product released:

- Acetic: release acetic acid, which causes problems of corrosion in certain metal substrates such as copper.
- Alkoxy: release alcohol (usually methanol)
- Aminic: when amine is released
- Oxime: These are special formulations releasing oximes, but with the peculiarity that in this case the reaction by-product is reused again in the polymerization reaction. This is why they are also known as neutral silicones

There are also silicones which cure by UV emission lamps to fix the adhesive on the substrates. Sometimes, this system is used with moisture cure.

Advantages of silicones:

- Provide good adhesion and sealing on various substrates.
- Keeps flexible within a temperature range of -55° C and 250°C, though some formulations can endure up to 350°C
- Good durability
- Resistance to moisture, ozone and UV radiation
- Excellent dielectric properties

Disadvantages of silicones:

- Can't be painted
- The acetic silicones produce a penetrating odor (smell of vinegar)
- Low resistance to hot oils, fuels and chlorinated products

Some areas of application of silicones:

- Cracks repair
- Adhesion and sealing of different materials (appliances, tires and hoses, electrical elements, glass ...)
- Avoid leaks
- Electrical insulation
- Coating of conveyors

Adhesive Selection Guidelines

Characteristics	Standard Epoxies	Urethane	Acrylic	Silicones	Polyolefins (Vinylics)
Adhesive type ^a	L1, L2, F	L, W, HM	L1, L2, W	L1, L2	F
Cure requirement	Heat, ambient	Heat, ambient	Heat, ambient	Heat, ambient	Hot melt
Curing speed	Poor	Very good	Best	Fair	Very good
Substrate flexibility	Very good	Very good	Good	Good	Fair
Shear strength	Best	Fair	Good	Poor	Poor
Peel strength	Poor to fair	Very good	Good	Very good	Fair
Impact resistance	Fair	Very good	Fair	Best	Fair
Humidity resistance	Poor	Fair	Fair	Best	Fair
Chemical resistance	Very good	Fair	Fair	Fair	Good
Temperature resistance (°C)	Fair	Fair	Fair	Good	Poor
Gap filling	Fair	Very good	Very good	Best	Fair
Storage (months)	6	6	6	6	12

^a Adhesive type: L1 = Liquid one part, L2 = Liquid two part, F = Film, W = Waterborne, HM = Hot melt.

Table 4.1- Selection guide of adhesives based on their properties.

Chapter 5: Surface treatments

As above mentioned, sometimes the substrate requires a surface treatment. The adhesion process is a surface phenomenon; consequently any intermediate substances formed (dust, oil...) need to be removed in order to ensure a good bonding. In some cases, the weak layers also need to be eliminated for increasing the wetting capacity of the surface of the substrate and to ensure a better bond.

Metal substrates have surface energies superior to the surface tension of the adhesives, so that they only require a cleaning treatment. On the contrary, polymers have low surface energy, making necessary a chemical modification of their surface to improve wetting. Thermoplastics are generally difficult to bond and need treatments such as flame oxidation, plasma, treatment with an ionized inert gas or the use of primers or adhesion promoters.

Once the surfaces have been prepared, the bonding process must be done as soon as possible in order to avoid the occurrence of new substances. In case that the materials need to be stored, special measures need to be taken in order to avoid the contamination of the substrates.

The surface treatments can be passive or active:

- Passive surface treatments are those which do not chemically modified the surface. Representative examples are: steam phase degreasing, ultrasonic bath treatment, mechanical abrasion, etc.
- Active surface treatments, at difference to the previous, do modify the chemistry of the surface of the substrate. These include: plasma treatment, anodizing, etching, corona discharge, flame treatment, etc

5.1. PASSIVE SURFACE TREATMENTS

5.1.1. Degreasing

This treatment is used to eliminate greases and oils from the surface of the substrates to be bonded (metals or composites). The specific method depends of the type of substrate. Metallic surfaces can be cleaned by immersion in a bath of a chlorinated solvent, such as trichloroethane, during 30 min or with a cotton impregnated with the solvent. In the case of composites or polymeric surfaces, where release agents are used, ketone and alcohol solutions or detergents are currently applied for their removal.

5.1.2. Mechanical abrasion

The objective of the mechanical abrasion is to increase the roughness of the surfaces, which improves the wetting of the substrate to the bonding agent, simultaneously to the cleaning of the surface by removal of contaminants and solid particles. This is used with metals and composites. Mechanical abrasion can be performed with sandpaper, wire brushes, sandblasting or mobile rollers, among others. Then, the generated particles which are deposited on the surface need to be eliminated, to that, solvents or clean air jets can be used.

5.1.3. Ultrasonic baths

When using ultrasonic cleaning treatments, the substrate is introduced in a tank which contains a solvent or a mixture of solvents. The effectiveness of the liquid on the surface to be treated is strengthening by the ultrasonic wave's radiation. This procedure allows a high quality cleaning of the surfaces, as particles in areas of difficult access can be reached. The type of solvent to be used depends on the characteristics of the contaminant.

5.2. Active surface treatments

5.2.1 Chemical Treatments

Chemical treatments are ideal in applications where special surface preparations are necessary, to increase surface energy above the adhesive, in addition to providing a large increase in the life of the bonding. However, they require rigorous controls due to waste generation and modification of the intrinsic properties of the materials.

There are several types of chemical treatments depending on the type of adhesive and substrate.

5.2.2. Low pressure plasma treatment

This treatment makes use of a plasma produced by ionization of a gas integrated by ions and electrons positively charged, which when collapse they produce a large amount of energy. In the low pressure plasma treatment, the gas is excited, with a high frequency and a high voltage, between two electrodes in a low pressure chamber. The possibility to use different types of plasmas (Argon, ammonia, nitrogen or oxygen) makes this process adequate for different materials. The oxygen of the air produces the best results, as it reacts with contaminants and breaks long chain molecules.

By his procedure, a triple action is achieved, as we not only clean the surface of the substrate, but we also improve the surface roughness and activate a surface initially inert.

5.2.3. Flame treatment

In this process a flame of a gas (fuel gas) or gas/oxygen is applied to the surface of the substrate, producing a partial oxidation and thus increasing its surface energy. It is easy to

control and adjust the gas/oxygen relation, the frequency, the exposure time and the proximity of the flame to the substrate.

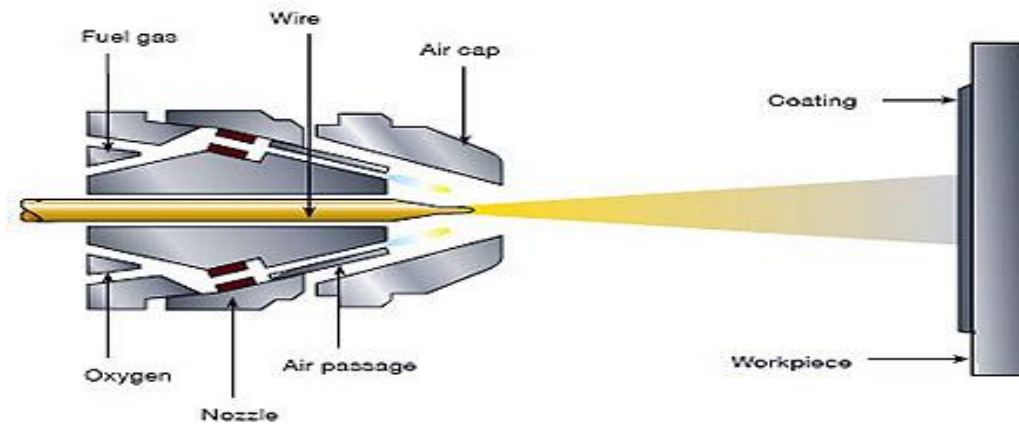

Figure 5.1- Example of superficial flame treatment.

5.2.4. Corona discharge

This procedure is also a low pressure plasma process. In this case, the plasma is generated by applying a high voltage between two metallic electrodes with a defined geometry. The substrate is placed in the gap between the electrodes and treated with the ionized gas. This process activates the substrate and increases its surface tension. At difference to the flame treatment, this can only be used with low thickness substrates

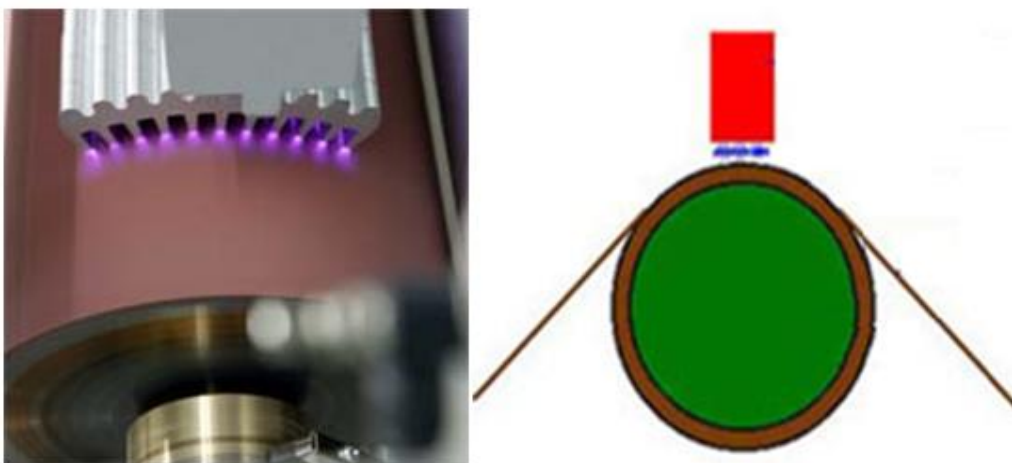

Figure 5.2- Example of corona superficial treatment.

5.2.5 Primers

These are substances based on diluted polyurethanes and silanes applied on the substrate surface in order to improve the interaction between the substrate and the adhesive and to protect the surface on which it is applied. The type of primer used, acting as an intermediate layer, depends on the type of the adhesive and the substrate.

In some cases, where an exhaustive control of the production process cannot be made, primers are used to avoid possible failures.

In addition, this type of treatment greatly increases the life of adhesion.

Substrate	Solvent Cleaning ^a	Intermediate Cleaning	Chemical Treatment or Other
Aluminum	Chlorinated solvent, ketone, or mineral spirits ^b	Detergent scrub	Sulfuric (96%) acid/sodium dichromate (77.8/22.2 pbw) solution at 25°C for 20 min; rinse with tap water followed by distilled water, dry for 30 min at 70°C
Beryllium/copper	Chlorinated solvent, ketone, or mineral spirits ^b	Wet abrasive blast	—
Copper	Chlorinated solvent, ketone, or mineral spirits ^b	Dry abrasion or wire brushing	Nitric (69%) acid/ferric chloride/distilled water (12.4/6.2/81.4 pbw) solution at 21–32°C for 1–2 min; rinse in tap water followed by distilled water; dry at 65°C maximum
Steel (stainless)	Chlorinated or aromatic solvent ^b	Heavy-duty alkaline cleaner	Nitric (69%) acid/distilled water (20/80 pbw) solution at 21–32°C for 25–35 min; rinse with tap water followed by distilled water; dry at 65°C maximum
Steel (mild)	Same as stainless	Same as stainless	Ethyl alcohol (denatured)/orthophosphoric (85%) acid (66.7/33.3 pbw) solution at 60°C for 10 min; rinse in tap water followed by distilled water; dry for 60 min at 120°C
Titanium, titanium alloys	Ketone or aromatic solvent	Mild alkaline cleaner or wet abrasive scour	Nitric (69%) acid/hydrofluoric (60%) acid/distilled-water (28.8/3.4/67.8 pbw) solution at 38–52°C for 10 to 15 min; rinse with tap water followed by distilled water; dry 15 min at 71–82°C; brush off carbon residue with nylon brush while rinsing
Ceramic	Ketone solvent	—	Sulfuric (96%) acid/sodium dichromate/distilled water (96.6/1.7/1.7 pbw) at 20°C for 15 min; rinse with tap water followed by distilled water; dry at 65°C maximum

^a Immerse, spray, or wipe.

^b Or vapor degrease with chlorinated solvents.

Table 5.1- Surface treatments of common metals and ceramics.

Substrate	Solvent Cleaning ^a	Intermediate Cleaning	Chemical Treatment or Other
Acetal (Delrin)	Ketone solvent	Dry abrasion or wet or dry abrasive blast	Sulfuric (96%) acid/potassium dichromate/distilled water (88.5/4.4/7.1 pbw) solution at 25°C for 10 sec; rinse with tap water followed by distilled water and dry at room temperature
ABS	Ketone solvent	Dry abrasion or wet or dry abrasive blast	Sulfuric (96%) acid/potassium chromate/distilled water (65/7.5/27.5 pbw) solution at 60°C for 20 min; rinse with tap water followed by distilled water; dry with warm air
Polycarbonate (PC)	Alcohol	Dry abrasion or wet or dry abrasive blast	—
Polyethylene (PE) and polypropylene (PP)	Ketone solvent	—	Sulfuric (96%) acid/sodium dichromate/distilled water (88.5/4.4/7.1 pbw) at 70°C for 60 sec; expose surface to gas burner flame until the substrate is glossy. Can also be treated with corona discharge or flame.

^aImmerse, spray, or wipe.

Table 5.2- Surface treatments of common plastics

Chapter 6: Advantages and disadvantages of adhesives

Adhesive bonds have the following advantages and disadvantages compared to other binding mechanisms:

6.1. ADVANTAGES

- Uniform stress distribution
- Improves the final appearance of the product
- No corrosion occurs, as in the case of joints by metal parts.
- It doesn't produce any deformation in the substrates, reducing the manufacturing cost
- Reduction of the weight in the final product
- Reduce the number of components
- High resistance to impact and fatigue
- Better design flexibility
- It allows the union of different materials
- Rigid unions

6.2. DISADVANTAGES

- Poor against peel strength and through-thickness
- It needs time to be cured
- Inability to disassembly
- Need of surface preparation
- Sensitive to environmental degradation (temperature, humidity ...)
- May require expensive tools

- Maybe of environmental concern

Chapter 7: Composite materials

Composite materials are defined as being formed by two or more mutually insoluble materials (commonly a reinforcement supported by a matrix), so that each retains its integrity. These materials combine the properties of other types of materials, profiting from their advantages and offsetting their shortcomings in such a way that their properties are superior (design capacity), and possibly unique in some specific respects, to those of the individual components (synergy).

The later provides the main reason for the development of composite materials. In fiber-reinforced plastics, fibers and plastics with some excellent physical and mechanical properties, are combined to give a material with new and superior properties. By combining fibers and resin a bulk material is produced with a strength and stiffness close to that of the fibers and with chemical resistance of the plastic. In addition, it is possible to achieve some resistance to crack propagation and an ability to absorb energy during deformation. This synergistic feature that is an effect exceeding the sum of the individual effects, of composite materials and structures is best illustrated by the bimetallic strip. This consists of two strips of metal with different thermal coefficients of expansion welded together along their length. Separated each of these strips remains flat when heated but when they are welded together the composite strip wends towards the metal with the lower coefficient of expansion. The bending is a new and distinct property of the composite strip.

Composite materials are made of a uniform and continuous phase, called the matrix that surrounds a discontinuous phase (Figure 7.1). This discontinuous phase may be in the form of:

- Particles, the arrangement of which gives uniform properties to the whole mass of the composite
- Chopped fibers or whiskers

- Continuous fibers, whose behavior is defined in terms of the direction of the loads relative to the fibers



Figure 7.1.- Composite materials with different discontinuous phases: (a) particles, (b) chopped fibers and (c) continuous fibres.

There was a rapid growth in the use of fibre-reinforced materials in engineering applications in the last decades. The most commonly used types of fibres are carbon fibres, glass fibres and synthetic polymer fibres (Kevlar). Prices and properties vary from one type to another and the selection will depend on the requirements of the final application. In a composite the fibre supports most part of the loads which propagate through the bonding between the two phases. These mean that physical and to some extent chemical compatibility is required between fibre and matrix. Therefore, the structure and properties of the fibre-matrix interface play a major role in the mechanical and physical properties of composite materials.

Currently the matrix shows rather low mechanical properties (organic resins, light metals or alloys, ceramics) and it is a ductile material (undergoes a substantial deformation under load before failure). In some cases, the matrix of the composite may also be brittle. The mechanical performance of the composite relies mainly on stiffness and strength of the fibres. The matrix generally represents 30% to 40% by volume of the composite. The functions of the matrix are to:

- Maintain the shape of the composite structure
- Maintain the reinforcing fibers aligned
- Act as a transfer medium for stresses

- Protect de fibers against abrasion and corrosion

7.1.-LAMINATE COMPOSITES

The characteristics and properties of structural material composites depend not only on the constituent materials, but also on the design geometry of the constituent structural elements.

Here we will focus on the structure of laminate composites (Figure 7.2). Laminate composites are made of stacked laminae (or panels) in parallel, reinforced with fibres, that have a very high strength in a preferential direction. The laminae are formed by rovings, mat or polymer-impregnated fabrics, bonded by some form of adhesive. If different materials are involved, the term we should use would be hybrid laminates. The lamina is the structural unit of the composite and it is a very thin monolayer material (0.1-1 mm).

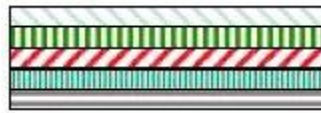

Figure 7.2.- Laminate composite

The mechanical properties of a composite depend on the properties of the constituent materials, the fibre and the matrix, as well as the way they are bonded (the interface). The fibre/matrix bonding is of special relevance for the transmission of stresses between both. Consequently, the properties of each lamina in the laminate will be determined by the following factors:

- The nature of the fibre

- The type of the fibre (roving, mat, ...)
- The percentage of the fibre
- The orientation of each lamina relative to a reference arbitrary axis

7.2.-LAMINAR ORIENTATION

We may refer to the orientation of each lamina as a function of the distribution of its fibres, which can be as follows:

-**Unidirectional**: when all the fibres are parallel to the direction of the applied load and orientated only in one direction (Figure 7.3). It provides extremely high directional properties.

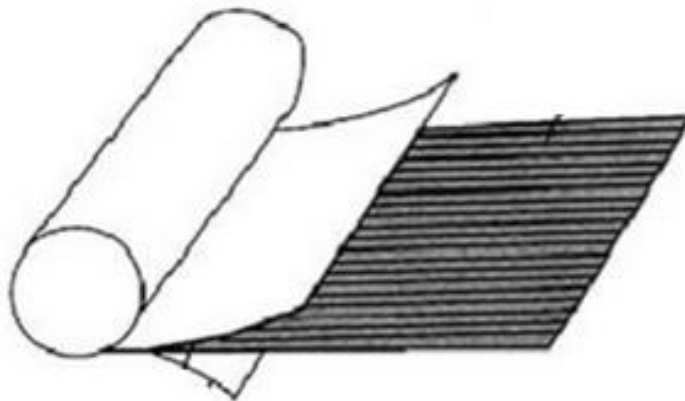

Figure 7.3.- Unidirectional lamina.

The advantages of a unidirectional lamina include:

- A high stiffness.
- The use of the layer to wrap the fibres, allowing a continuous transmission of the load through the fibres at a long distance.
- A lower concentration of waste.

-Bidirectional: when the fibres are distributed in two perpendicular directions on the inside of the lamina. The amount of fibres in both directions does not necessarily need to be the same.

-Multidirectional: when the fibres are orientated in any direction, and can be in different directions on the different lamina.

-Woven fabric: when the fibres are in textile form with filaments crossing almost at right angle (Figure 7.4). This type of lamina can also be treated as bidirectional.

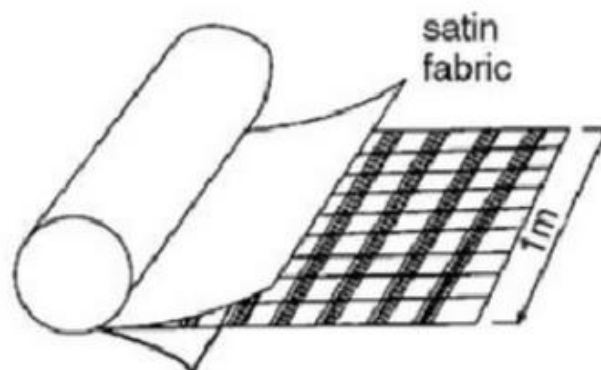

Figure 7.4.- Woven fabric lamina.

The advantages of the woven fabric laminae are

- Their more balanced properties compared to unidirectional ones
- Their shorter production time compared to multidirectional ones

The disadvantages of this kind of laminae are their lower traction resistance and modulus.

7.3-ADHESIVE BONDING FOR COMPOSITE LAMINATES

There are several ways to bond the laminae in a composite with adhesives. Some of them are as follows:

-Co -curing: the act of curing a composite laminate and simultaneously bonding it to some other uncured material. All the resins and adhesives are cured during the same process.

-Co -bonding: the curing together of two or more plates, of which at least one is fully cured and at least one is uncured. This option requires careful surface preparation of the previously cured plate. Additional adhesive may be required at the interface.

-Secondary bonding: the joining together, by the process of adhesive bonding of two or more pre-cured composite parts, during which the only chemical or thermal reaction to occur is the curing of the adhesive itself. This requires careful preparation of each previously cured substrate at the bonding surfaces. Usually it also requires well-designed featuring to align and clamp the parts during processing.

Chapter 8: Theoretical assumptions

Due to the intrinsic complexity of the composites, in order to determine the properties of a laminate, several assumptions need to be made. Even if these assumptions are not entirely true, they will help to understand the final analysis of its behaviour. These include:

1-Material homogeneity

Initially composites are heterogeneous materials. However their mechanical analysis is based on the assumption that they are homogeneous. This apparent contradiction is due to the fact that a material can be viewed microscopically or macroscopically. From the first they are heterogeneous, but from a macroscopic point of view, they look homogeneous and behave so when tested.

2-Material linearity

Not all the properties of the composites are linear. The contribution of linearity depends on the type of sample, the test to be performed and also the experimental conditions. In some cases, such as the stress-strain curves of laminate composites they are considered as linear to simplify their analysis.

3-Material orthotropy

The orthotropy is given by the variation of the mechanical properties as a function of the orientation. An orthotropic material contains symmetrical planes and it can be characterized by four independent elastic constants. A unidirectional lamina has three mutually perpendicular planes of symmetry as shown in Figure 8.1 and is, orthotropic. A woven roving lamina is orthotropic and a chopped strand mat lamina is usually assumed to be isotropic in the plane of the lamina.

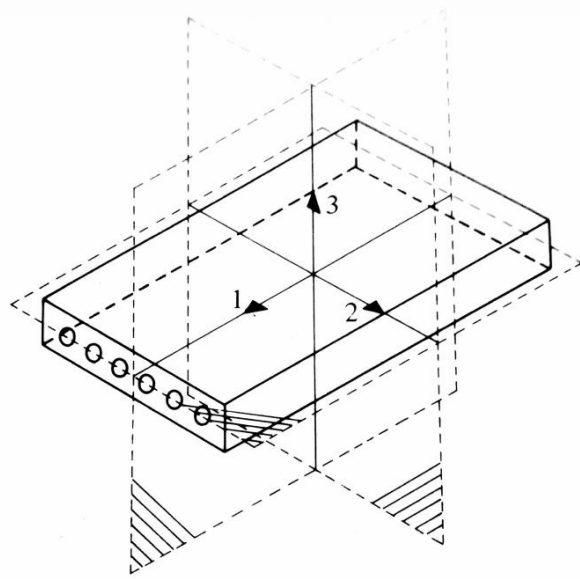

Figure 8.1.-Orthotropy in a unidirectional lamina

4-Residual stresses

The microscopic heterogeneity (mentioned above) of a composite implies differences between the thermal expansion behaviour of the fibre and the matrix, which generate residual stresses in the laminate after curing. However, it is assumed that these stresses do not affect the stiffness of the composite and it is considered that the composite uniformly strains.

Chapter 9: Lamination theory

The development of protocols for the evaluation of the stresses and strains of the laminates must take into consideration the fact that the thickness of the laminates is much lower than the in-plane dimensions. The thickness of a single lamina ranges from 0.13 to 0.25 mm, so that although if we are dealing with several laminae, we can still analyse them with the thin plate theory.

The premises of the thin plate theory are as follows:

- 1-Compared to the in-plane dimensions, the thickness of the ply is much smaller
- 2-The shapes of the surface of the deformed ply are small in comparison to the whole unit
- 3-The normal to the surface of the original ply continues being normal for the deformed ply
- 4-The vertical deflexion does not change across the thickness
- 5-The normal stress to the ply surfaces is no significant

On the basis of premises 2 and 4, we can define the displacement field as:

$$\begin{aligned}u_z &= u_z^{\circ}(x, y) \\u_x &= u_x^{\circ}(x, y) - z \frac{\partial u_z}{\partial x} \\u_y &= u_y^{\circ}(x, y) - z \frac{\partial u_z}{\partial y}\end{aligned}\tag{9.1}$$

These relations and a linear variation through the thickness indicate that the displacement in the plane is a mid-plane displacement, designated by the superscript ($^{\circ}$).

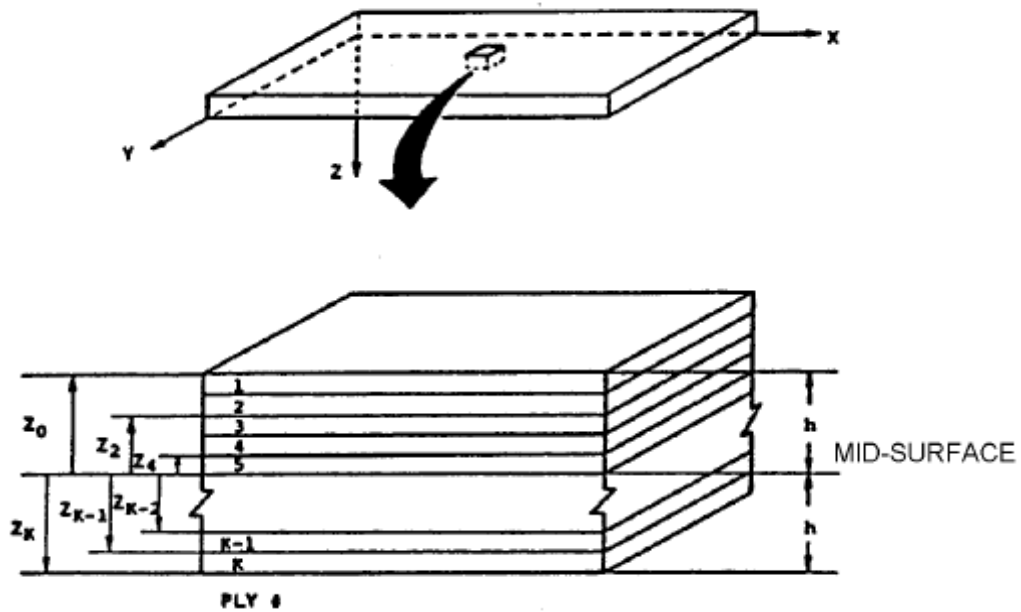
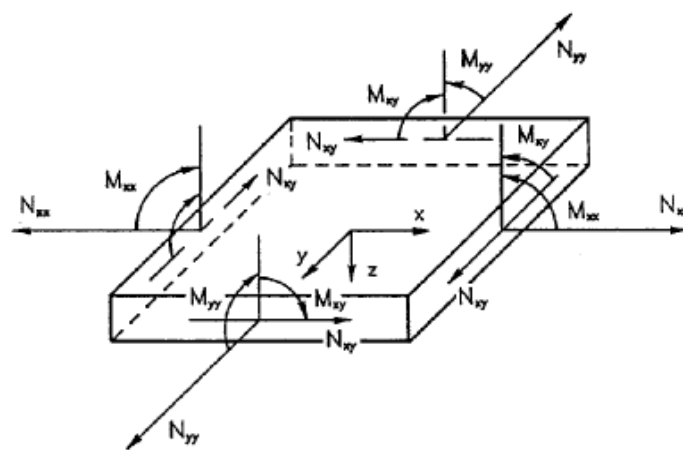

Figure 9.1.- Construction of a laminate

At our convenience, we will use the resultant stress and moments instead of the stresses for the rest of the development of the lamination theory. Figure 9.2 shows the representations and definitions.



$$\{N\} = \int_{-h}^h \{\sigma_x\} dz$$

$$\{M\} = \int_{-h}^h \{\sigma_x\} z dz$$

Figure 9.2.- Resultant stresses and moments.

The lamination theory is used to predict the internal stresses, the stiffness and the dimensional stability. The combined influence of the different types of loads and moments on the plate can be described by using the ABD matrix:

$$\begin{bmatrix} N_x \\ N_y \\ N_{xy} \\ M_x \\ M_y \\ M_{xy} \end{bmatrix} = \begin{bmatrix} A_{11} & A_{12} & A_{16} & B_{11} & B_{12} & B_{16} \\ A_{12} & A_{22} & A_{26} & B_{12} & B_{22} & B_{26} \\ A_{16} & A_{26} & A_{66} & B_{16} & B_{26} & B_{66} \\ B_{11} & B_{12} & B_{16} & D_{11} & D_{12} & D_{16} \\ B_{12} & B_{22} & B_{26} & D_{12} & D_{22} & D_{26} \\ B_{16} & B_{26} & B_{66} & D_{16} & D_{26} & D_{66} \end{bmatrix} \begin{bmatrix} \varepsilon_x \\ \varepsilon_y \\ \varepsilon_{xy} \\ \kappa_x \\ \kappa_y \\ \kappa_{xy} \end{bmatrix} \quad (9.2)$$

where **N** are the loads, **M** are the moments, ε are the strains, κ are the curvatures, **A_{ij}** are elongational and shear stiffness, **B_{ij}** are elongation-bending attachment stresses and **D_{ij}** bending and torsion stiffness.

Chapter 10: Laminate stacking sequence

The distribution of the different ply orientations across the laminate thickness determines the stacking sequence. As the number of plies with chosen orientations increase, more stacking sequences are possible. For example, a symmetric 8-ply laminate with four different ply orientations has 24 different stacking sequences.

The stacking sequence of the laminates must be guided by the following aspects:

- The strength and stiffness in a direction depend on the orientation of the fiber
- A laminate should always be symmetrical about its midplane, and balanced to avoid anomalous distortions of the structure due to temperature changes.
- The most common orientations are 0, 90 and +/-45. Figure 10.1 shows the possible arrangements. The right combination of these orientations serves to control the strength and stiffness in any direction. It is possible to use different orientations, but generally this only complicates the manufacture of the structure.

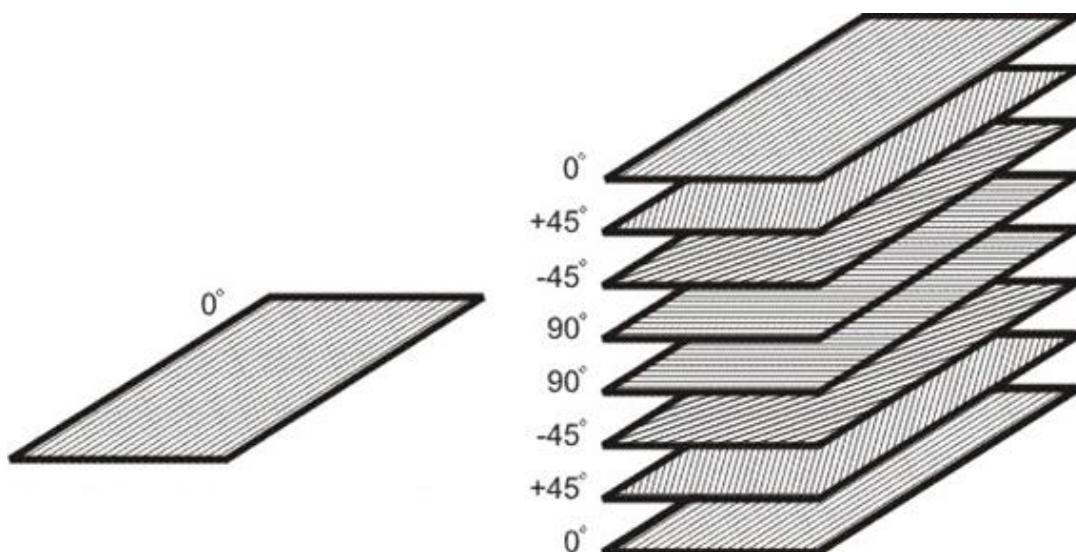

Figure 10.1.- Plies orientation in a stacking sequence.

10.1.-DESIGN OF A STACKING SEQUENCE

The choice of the coordinates system used for the laminate will determine its stacking sequence, which is totally arbitrary, but some general rules are usually followed to facilitate calculations and general understanding.

First, we will define the 0° fiber direction (and thus the x-axis). The plies that are not at 0° must be assigned an angle. To do this, start from the x-axis and rotate towards the fiber direction of the ply being defined. Clockwise rotations are positive angles, and counterclockwise rotations are negative angles, although the reverse procedure can also be applied since only plane-stress is being examined for plates and the material is the same whether viewed from one surface or the other.

Once the angles have been selected ($0^\circ, \pm 15^\circ, \pm 30^\circ, \pm 45^\circ, \pm 60^\circ, \pm 75^\circ, 90^\circ$), the total number of plies and proportion of each orientation in the laminate are set and a stacking sequence is chosen (Figure 10.2).

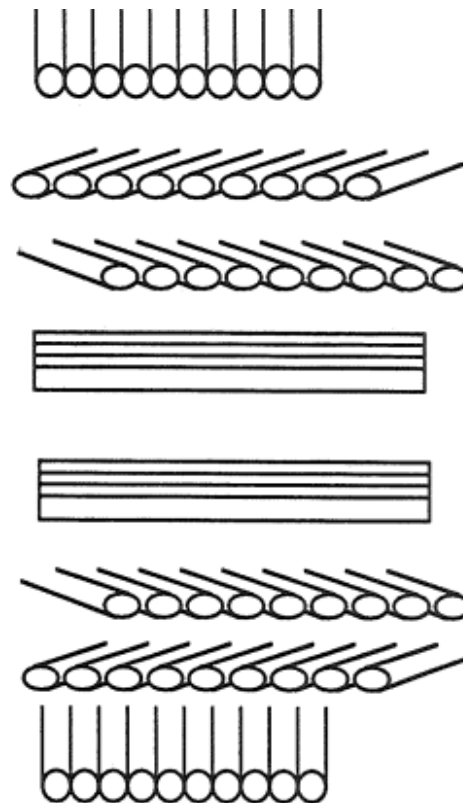

Figure 10.2.- Stacking sequence of 0° , $+45^\circ$, -45° , 90° , 90° , -45° , $+45^\circ$, 0°

Chapter 11: Design of laminate composites

Laminate composites are in high demand by the industry because of their high specific stiffness and strength, especially for applications where weight reduction is crucial. By means of laminate composites, the weight of a structure can be reduced significantly. Further reduction is also possible by optimizing the material system itself.

In the design of laminate composites, the goal is to obtain a resistant material with a high load capacity and low weight. To achieve this certain factors need to be considered:

- The cost of the raw materials and of fabrication
- The mass of the material which affects energy costs

- Stiffness against deformation and buckling limits.

- Thermal and moisture expansion coefficients to maintain dimensional stability.

Now we will discuss some of the mechanical design issues:

1. Environmental effects:

Temperature and humidity play an important role in the life of a composite, as they may undermine the adhesion at the fiber-matrix interface. Consequently, these are critical factors which cannot be underestimated.

2. Fracture resistance

Fracture mechanisms are not simple due to the fact that the cracks produced in a composite can generate fiber breakage, damaging the matrix and debonding the layers. Additionally, single critical stress intensity factors and strain energy release rates cannot determine the mechanics of the fracture process by themselves.

3. Fatigue resistance

The life of the structural materials subjected to repeated cycles of loading is considerably shorter. The factors influencing fatigue behavior are: the characteristics of the fiber and the matrix, the volume percentage of the fibers, the interface and the laminate stacking.

4. Interlaminar stresses

The interlaminar stresses are due to the differences in the elastic module and angle between the layers of laminated composites, which may cause the delamination of the layers at the edges, so that reducing the life of the laminate structure.

5. Impact resistance

Resistance to impact depends on: interlaminar strength, stacking sequence and the nature of the impact (velocity, mass, size of the impacting object...). Sometimes it is also difficult

to visually identify the damage produced by impact. In general, impact reduces the strength of the laminates and also causes delamination of the composite.

Chapter 12: Damage and failure modes in laminate composites

12.1.-TENSION

The tensile break of integrated laminates with multidirectional plies includes a series of pre-catastrophic failure steps, which include:

- Localized fiber breaks
- Matrix damage

A catastrophic failure is expected when the tensile resistance of any ply in a laminate is overcome, but the laminate can be separated without the fracture of fibers by coupling different shapes of matrix damage.

The different mechanisms of fracture that can be seen in a micro and macro scale in a multidirectional laminate are shown in Figure 12.1

The appearance ways of failures depend on the load conditions and material characteristics. The matrix failure (transversal cracks, delamination) and isolated fiber breaks happen at stress levels below the static resistance. The load is redistributed to localized failures until the critical damage level is reached.

The critical micro-fracture mechanisms shown in Figure 12.1(a) include localized fiber failure and debonding of the fiber/matrix interface. These mechanisms usually appear in aligned plies with a principal axis of tension stress. The stress levels of the laminate in which these failures occur depend on the redistribution of the load based on the damage state of the adjacent plies.

A limited number of fiber breaks is allowed inside a lamina before it fails in its totally, which can control the catastrophic failure of the laminate.

The intralaminar cracks of the matrix are aligned parallel to the fiber and span the thickness of a ply or a group of them with the same orientation (Figure 12.1(b)). These cracks have been called trans-ply cracks or ply splits, depending on the crack being in angle or parallel to the tensile load axis, respectively.

The interlaminar failure of the matrix (delamination) can appear near to the edges or in the intersections between the interlaminar cracks. Delamination is a consequence of excessive normal and shear stresses.

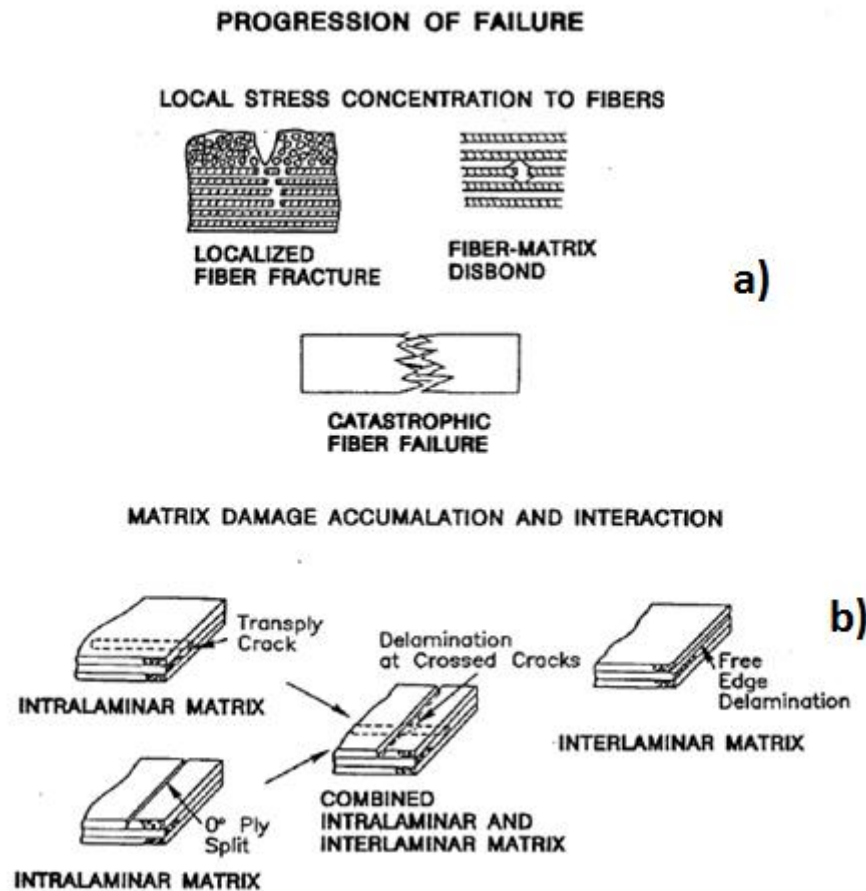

Figure 12.1.- Failure mechanisms for tension-loaded laminates

12.1.1.-Matrix cracks

They appear in the laminate due to a combination of mechanic and environmental stresses. The transversal are aligned with the fibers and, when they are totally developed, span the thickness of the ply or the ply groups stacked in the same direction (orientation). The matrix cracks redistribute the local stresses in the multidirectional laminates, allowing a crack density that is based on the applied load and the environmental history. They can be derived from the fabrication process.

The initial failure in 0° plies occurs in places near intralaminar cracks in the neighboring off-axis plies. When the matrix cracks span a ply it was found that the stress concentration

is lower and it is localized in a small surrounding area, which doesn't affect the tensile resistance.

Intralaminar cracks span the total thickness of multiple of-axis plies. The concentration of stresses associated to a near ply grows with the thickness of the stacked plies, which affects the tensile resistance.

Matrix cracks contribute to delamination. The growth of the surface area due to a network of cracks can also change the physical properties of the composite, like: thermal expansion, liquid permeability and oxidation stability. The residual stresses generated by differences in the thermal and moisture expansion of the components affect the formation of cracks in the matrix. In general, the residual tensile stresses develop transversally to the fiber when multidirectional composites of polymeric matrix are subjected to temperatures below the free residual stress temperature. This happens during the temperature drop as a consequence of the higher unconstrained shrinkage of the lamina in the transversal direction to the fiber than in the fiber direction. As the moisture is absorbed by the laminate, the swelling of the matrix compensates the thermal contraction, lowering the fiber transversal tensile stresses.

The critical stress or strain produced by the beginning of the cracking in the plies of a laminate has been referred as in situ laminar resistance, which is not a material constant. This resistance increases when the thickness of the group of laminae with the same orientation decreases. Continuous laminates can impose limitations to the formation of cracks in the matrix, depending on the orientation of the fiber.

It is typical to find resin-rich interlaminar layers (RIL) materials in the aerospace industry. The effect of the in situ decreases if there is a RIL with a significant thickness between the plies. When the RILs are relatively soft, some of the imposed limitations by the neighbor laminae are eliminated.

12.2.-COMPRESSION

The resistance to compression is related to the local response of individual ply groups. Assuming that there is no damage in the matrix due to impacts or loads, the resistance and local stability of aligned plies in the direction of the load axis will determine the final failure (also the location of the plies that endure the relative load to the surface of the laminate may contribute).

The load of short wave length of buckling is reduced when critic plies are localized in the outer part of the stacking sequence.

When there is damage in the matrix the local reaction of the combination of ply groups affect the resistance to compression. The stability and distribution of the load inside the groups of single laminae is crucial for the local response of the plies.

In the Figure 12.2 we can find three different kinds of local failure to compression. It is observed that they depend on θ for $(\pm\theta)_s$ types. The three kinds of failure can be combined when delamination happens to determine the resistance to compression of a determinate stacking sequence. The failures 1 and 2 of the in-plane matrix by shearing and compression were observed for $(\pm\theta)_s$ type laminates, with $15^\circ \leq \theta \leq 90^\circ$ and $60^\circ \leq \theta \leq 90^\circ$, respectively. The failure 3, shear mode of fiber microbuckling, is the most common in composites, which begins in laminates of the $(\pm\theta)_s$ type, with $0^\circ \leq \theta \leq 10^\circ$.

Depending on the fiber-matrix combination, the local failures for this kind of laminates include a combination of:

- Fiber failure (shearing, kinking, bending)
- Matrix separation (yielding)

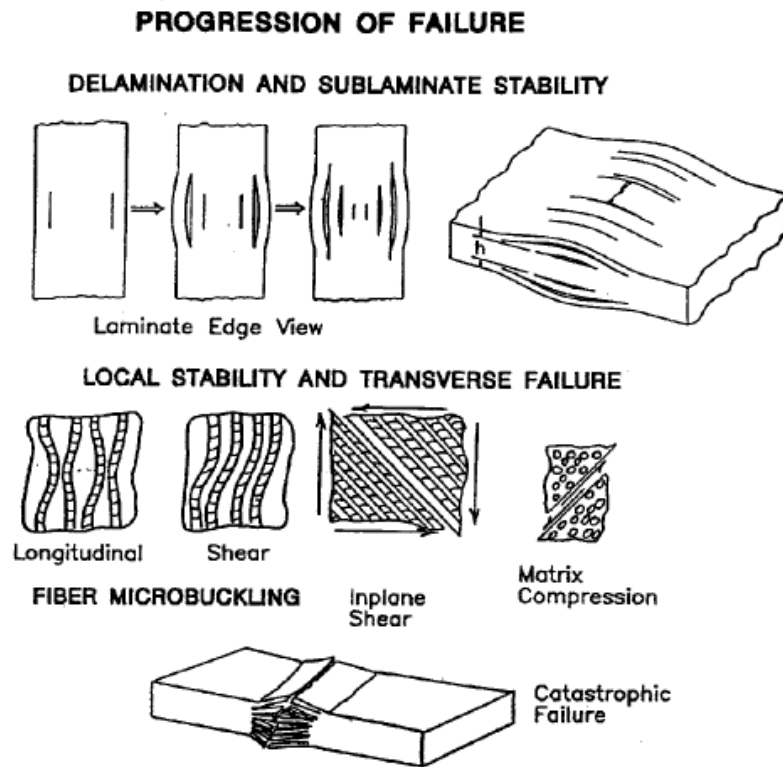

Figure 12.2.- Failure mechanisms for laminates loaded under compression

Chapter 13: Buckling and crippling

Under compression stresses there are several factors that must be considered, which involve an initial buckling, postbuckling, and crippling. At crippling we find that the damage turns to be permanent, making delamination appear due to interlaminar tensile or shear stresses.

13.1.-BUCKLING

Accurate prediction of structural response characteristics is a challenging problem in the analysis of laminate composites due to their orthotropic structural behavior (Chapter 8), the presence of various types of couplings and due to the reduced thickness of the structural elements making up the composites. Thus, an accurate buckling analysis of laminate composite plates is an important part of structural design.

Initial buckling is defined as that which occurs under a load that results in incipient out-of-plane displacements. The classical equations are elastic and finite transverse shear stiffness effects are usually neglected (except for some types of plate geometries).

The equations and representations for different types of buckling are shown below.

a	length
b	width
B_{ij}	stiffness coupling terms of laminated plate
D_{ij}	flexural/twisting stiffness terms of laminated plate
$F_{x,cl}^{cr}$	classical orthotropic longitudinal compressive buckling stress
$F_{x,i}^{cr}$	initial longitudinal compressive buckling stress from test
F_x^{cc}	longitudinal crippling stress from test
F_x^{cu}	longitudinal ultimate compressive stress of laminate
$N_{x,cl}^{cr}, N_{y,cl}^{cr}$	classical orthotropic longitudinal and transverse compressive uniform buckling loads, respectively
$N_{x,i}^{cr}$	initial longitudinal uniform buckling load from test
$N_{x,w}^{cr}$	longitudinal compressive uniform buckling load based on anisotropic theory, including transverse shear effects
N_x, N_y	longitudinal and transverse applied uniform loads, respectively, on a plate
$P_{x,i}^{cr}$	total longitudinal initial buckling load from test
$P_{x,i}^{cc}$	total longitudinal crippling load from test
t	thickness

$$N_{x,cl}^{cr} = \frac{2 \Pi^2}{b^2} [(D_{11} D_{22})^{1/2} + D_{12} + 2 D_{66}] \quad (13.1)$$

Equation 13.1 is the most frequently used for plate buckling. It is also valid for fixed boundary conditions on the loaded edges, which must be considered to prevent local brooming, because all the test are performed with fixed boundary conditions on the loaded edges.

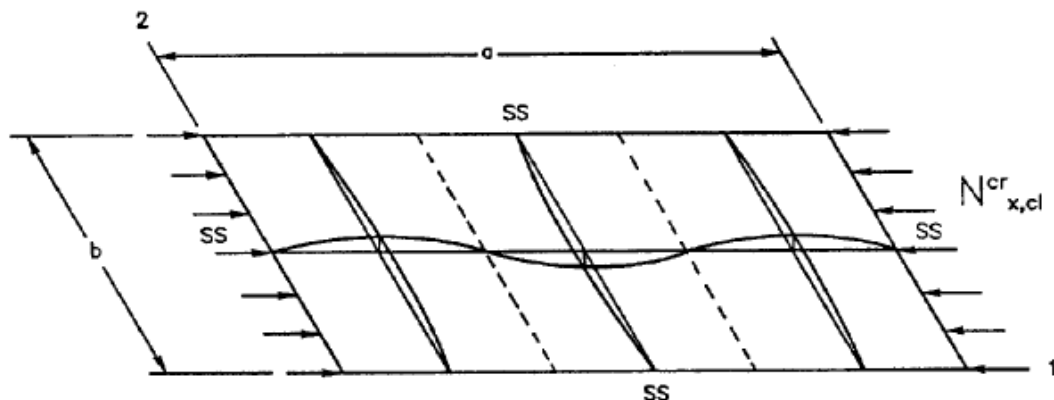

Figure 13.1.-Uniaxial loading - long plate with all sides simply supported

$$N_{x,cl}^{cr} = \frac{\Pi^2}{b^2} \left[4.6(D_{11}D_{22})^{1/2} + 2.67D_{12} + 5.33D_{66} \right] \quad (13.2)$$

Equation 13.2 compared to others, has not had the comprehensive experimental study. However, by supposition we can assume that the effect of transverse shear on narrow plates is very similar to the plates with all edges simply supported.

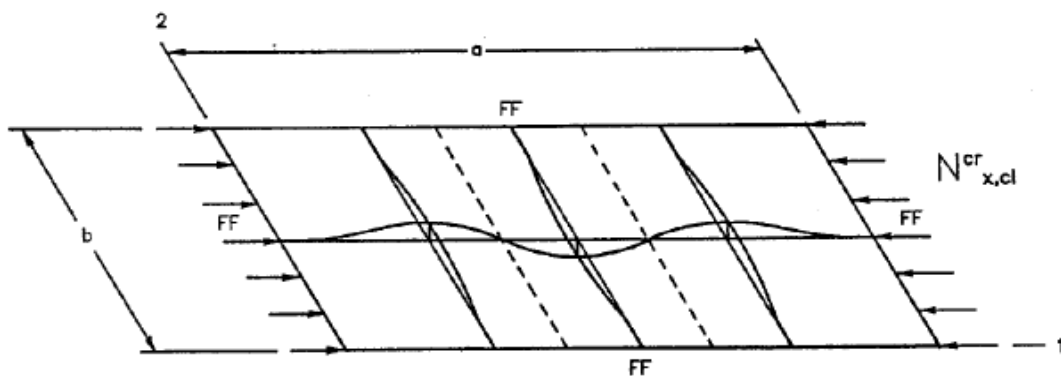

Figure 13.2-Uniaxial loading - long plate with three sides simply supported and one unloaded free edge

$$N_{x,cl}^{cr} = \frac{12D_{66}}{b^2} + \frac{\Pi^2 D_{11}}{a^2} \quad (13.3)$$

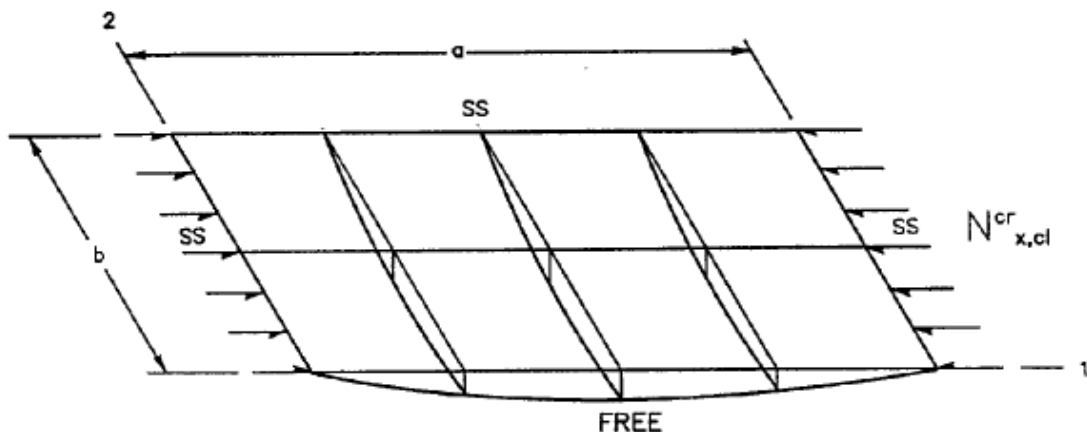

Figure 13.3-Uniaxial and biaxial loading - plate with all sides simply supported

$$N_{x,cl}^{cr} = \frac{\pi^2}{b^2} \frac{D_{11}m^4(b/a)^4 + 2(D_{12} + 2D_{66})m^2n^2(b/a)^4 + D_{22}n^4}{m^2(b/a)^2 + \phi n^2} \quad (13.4)$$

This orthotropic buckling equation 13.4 must be minimized with respect to the longitudinal and transverse half-wave numbers, m and n, where:

$$\phi = N_y / N_x$$

$$N_{y,cl}^{cr} = \phi N_{x,cl}^{cr}$$

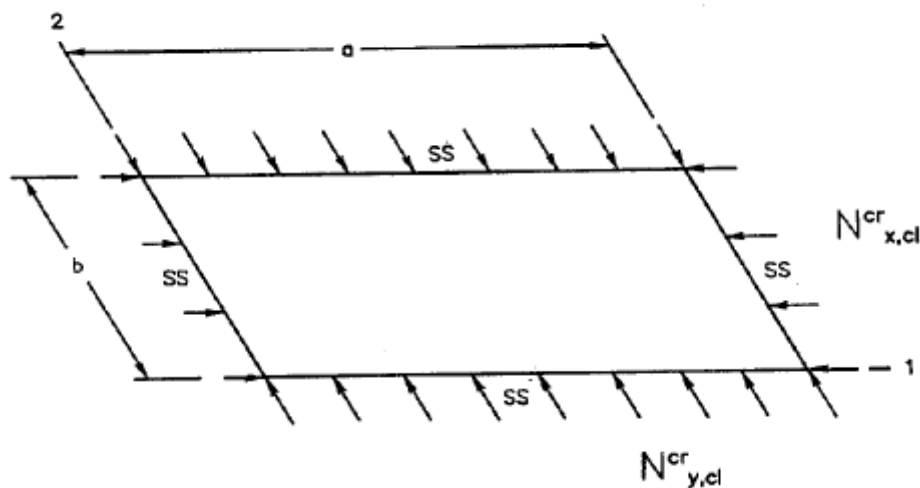

Figure 13.4-Uniaxial loading - plate with loaded edges simply supported and unloaded fixed edges

$$N_{x,cl}^{cr} = \frac{\pi^2}{b^2} \left\{ D_{11}m^2(b/a)^2 + 2.67D_{12} + 5.33 \left[D_{22}(a/b)^2 + (1/m)^2 + D_{66} \right] \right\} \quad (13.5)$$

Equation 13.5 must also be minimized with respect to the longitudinal half-wave number, m.

13.2.-POSTBUCKLING

Is the ability of a compressive member or stiffened panels to carry loads well in excess of the initial buckling load. The actuation range works between the initial buckling load and a higher load finalizing in failure, like delamination at the free edge of a compressive member or the disbonding of a stiffener from the panel. If a stiffened panel works in compression the load is distributed through the skin and the stiffeners in proportion to their respective stiffnesses.

The tangent stiffness of the skin at initial buckling is reduced sharply, which makes a portion of the total load be carried by the stiffeners. The tangent stiffness at buckling for an isotropic material working in a linear elastic way is reduced to the half of its initial value. For composite panels, the tangent stiffnesses are functions of the material properties and lay-up. Local buckling of one or more of the plates that a stiffener is made of will also reduce the in-plane stiffnesses of the affected elements and will cause the load to shift to the unbuckled portions of the stiffener. The upper limit of the postbuckling range is known as crippling, which is the permanent failure.

13.3.-CRIPPLING

Compressive crippling is known as a failure in which the cross section of a stiffener is loaded under compression and becomes distorted in its plane without any transfer or rotation of the column. In the Figure 13.5 we can see some of the typical deflected shapes of angles and stiffeners sections tested in crippling. Angles or cruciforms loaded under a compression load are commonly used as crippling specimens for the "one-edge-free" laminae. Channels, or supported compressive panels, usually are used for the "no-edge-free" case, in which the central channel segment is approximately simply supported with a "no-edge-free".

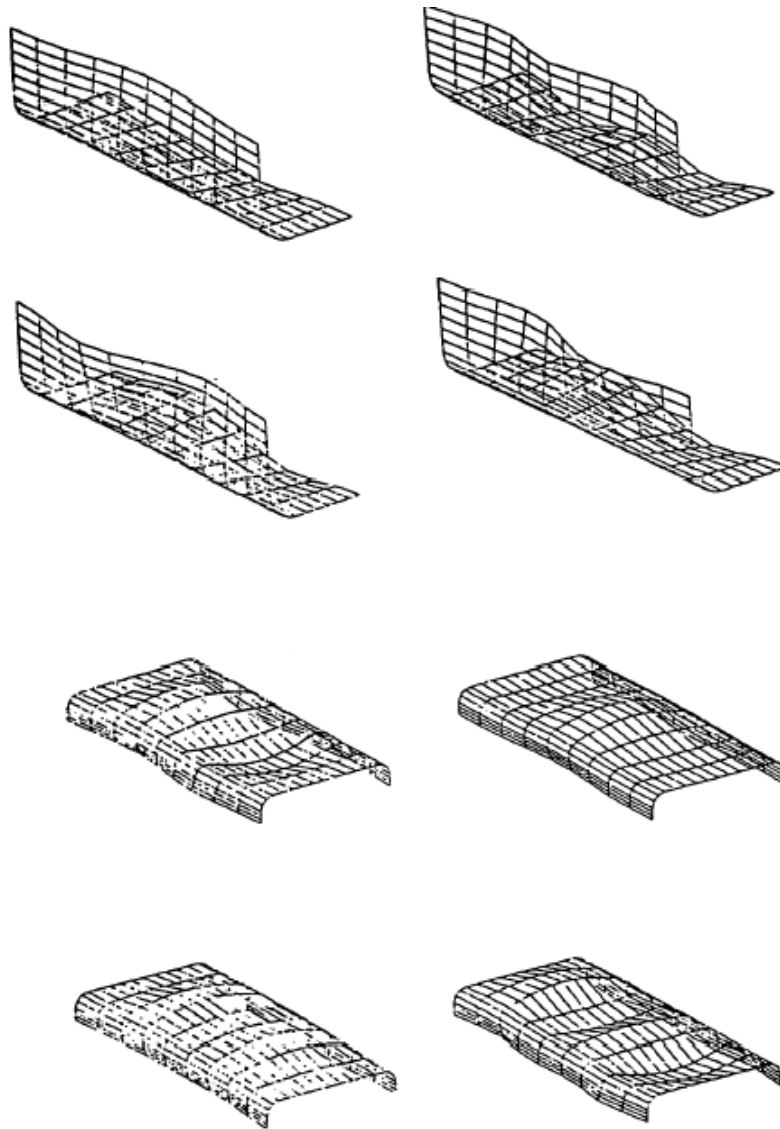

Figure 13.5-. Typical crippling shapes

Chapter 14: General Considerations

14.1.-RESIDUAL STRESSES

Curing stresses have not appreciable effect on the laminate properties which are controlled by the fiber. In spite of that, resin residual stresses can be larger than the mechanical stresses required for failure and high enough to produce microcracking in the resin before the application of any mechanical load.

14.2.-THICKNESS EFFECTS

Most of the differences found when comparing laminates of different thickness can be explained from the residual stresses developed on processing. The internal stresses generated may develop voids, delamination and microcracks or produce laminate residual stresses in the laminate that affect the properties of the material. Some of these can also be produced by environmental impact related to temperature and moisture conditions.

In the case of laminates with the same thickness the difference in their behavior are mainly related with processing and can be minimized by optimization of the curing cycle and a proper process control. Residual stresses may result from the occurrence of non-isothermal conditions during the solidification stage. The degree of volumetric contraction will be different in the different laminae at any time of the cycle, thus generating tensile stresses at the inner part of the laminate and compression stresses at the surface.

In general terms and summarizing, we can affirm that the variation in the properties of materials made of laminate composites are mainly the result of thermal residual stresses, although the environmental effects and other process parameters (different to temperature) may also have some contribution.

14.3.-EDGE EFFECTS

The stress state between the laminae with different orientations is very complex at the free-edge of the laminate, in both along straight edges and around the holes. Failure in some cases is a consequence of delamination in zones with strong interlaminar stresses produced by a low interlaminar strength. The effects of the free-edge stresses are sufficient to cause a significant reduction in the strength of a sample in both, static and stiffness tests.

14.4.-TRANSVERSE TENSILE PROPERTIES EFFECTS

Transverse strength properties play only a minor role in establishing cross-ply laminate strengths. It is, however, well-known that the effective "in-situ" transverse strength of transverse plies is larger than the strength of an individual lamina.

In-plane shear tests on laminae exhibit relatively high strains to failure. The much lower transverse tensile strains to failure indicate a marked notch sensitivity that is avoided in cross-ply laminates. The initial cracks that cause failure in the laminae are stopped by the fibers with other different directions, and the laminate continues functioning in an effective way.

14.5.-LAMINATE STACKING SEQUENCE EFFECTS

Stacking sequence describes the distribution of ply orientations through the laminate thickness. The fact that the possible stacking sequences increase with the number of plies (Chapter 10) facilitates the optimization of the performance of a composite.



The stacking sequence of the laminate affects structural properties of a composite such as stiffness, dimensional stability and strength. The relation is different depending on the property; consequently the selection of a stacking sequence will be done according to each specific application.

The design of a laminate starts with an initial selection of the number of plies and the ply angles required by the application. The sequence is considered heterogeneous when there is a preferential stacking of specific orientations at different locations across the laminate thickness.

Chapter 15: Applications of laminate composites

Laminate composites are mainly designed for structural applications. These include the aeronautics, automotive and marine industries. With rising fuel prices, lightweight structures and materials (like composites) received more attention. Composite materials offer high stiffness-to-weight and strength-to-weight ratios when compared with traditional metallic materials. Traditionally, composite materials were generally costly which made them attractive only to a very limited number of applications (e.g., the defence industry). Advances in their manufacturing and new innovations has lowered the cost of these materials and made them reasonably competitive. They have gained more and more usage in the last 3 decades in the aerospace industry and more recently in the automotive industry. In automotive design, they yield lighter structures which have positive impact on fuel economy and emissions among others. However, improvements in proper modelling and analyses still need to be undertaken to ensure other properties such as durability, noise, vibration and harshness. Composite materials offered for real applications in the automotive industry vary from thermo-plastics to laminated and fibre-reinforced structures. A representative example of the use of composites in automotive applications is the 2016 VW GOLF (Figure 15.1).

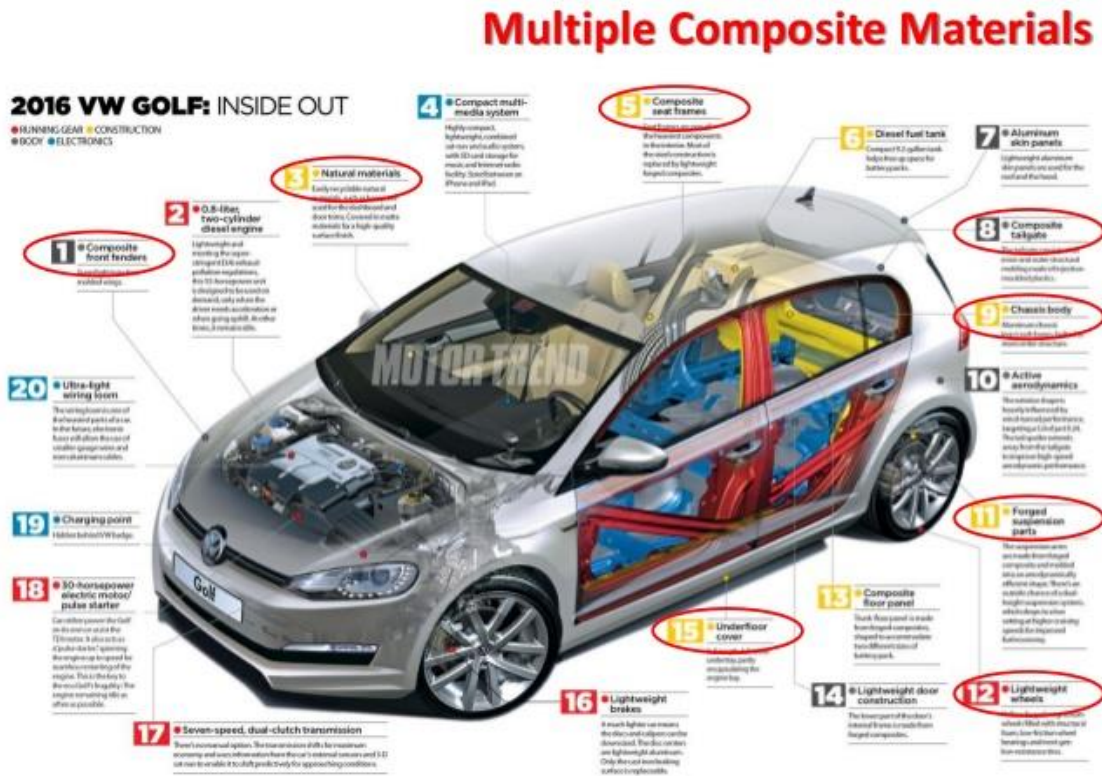

Figure 15.1-. Composite materials as automobile components.

The use of composites in aeronautics has increased considerably in the last few years. The largest aeronautic companies, Airbus and Boeing, have progressively incorporated these materials in different parts of the aircrafts. Figure 15.2 shows the evolution of the use of composites by Airbus since 70s up to a few years ago, and the parts into which these materials have been incorporated. Another clear example is the case of the Boeing 787 body which contains 50 % of carbon laminate composites as against 12 % for the Boeing 777 (Figure 15.3).

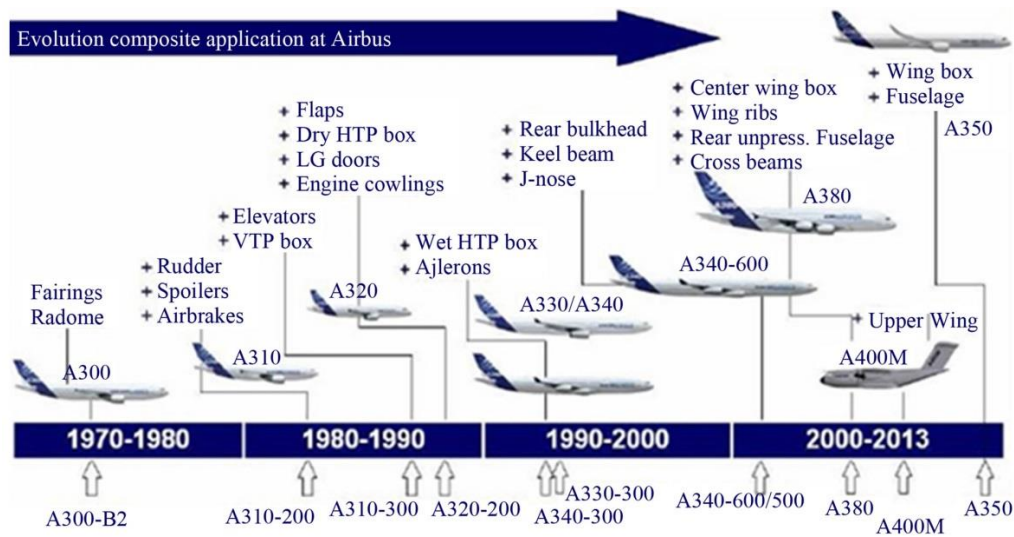

Figure 15.2.- Evolution of composites utilization in Airbus aircrafts.

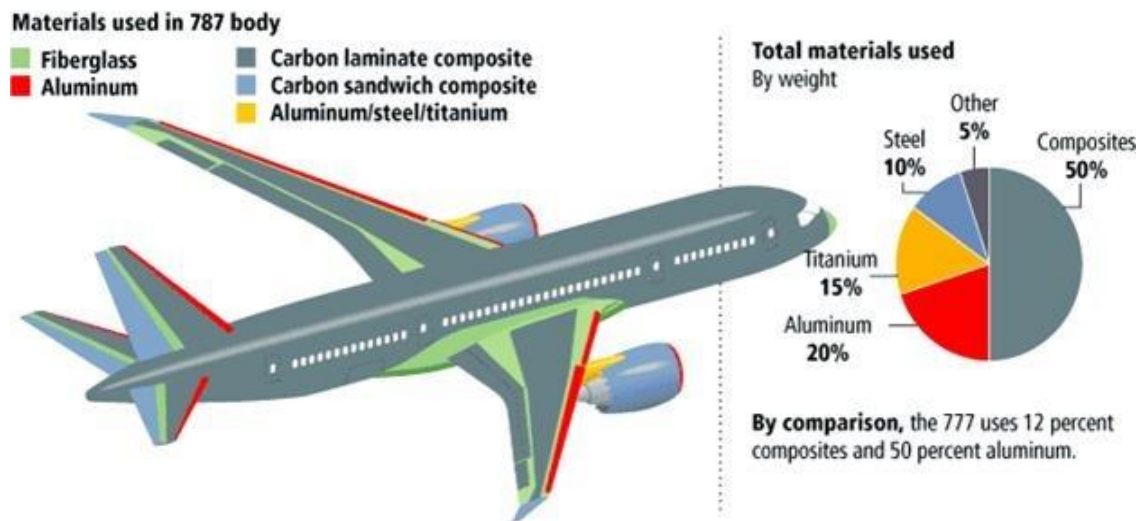

Figure 15.3.- Laminate composites in Boeing aircrafts.

Moving to marine applications, the first use of fibre reinforced polymer (FRP) composite material was in the construction of boats shortly after World War II. Boat builders began to use FRP composites instead of timber, which was traditionally used in small maritime craft, because wood was becoming increasingly scarce and expensive. Timber was also losing favour with many boat builders and owners because wooden boats were easily degraded by



seawater and marine organisms and therefore required ongoing maintenance and repairs that can be expensive. The earliest attempts to fabricate a boat hull with FRP composites was in 1947 when twelve small surf boats were made for the United States Navy. Most maritime craft are built using glass reinforced polyester composites. The application of FRP composites to maritime crafts was initially driven by a need for lightweight, strong, corrosion resistant durable naval boats. The high acoustic transparency of composites also resulted in their use in sonar domes on submarines.

Bibliography

BOOKS

- (1) **Liesa F. y Bilurbina L.(1990):** *Adhesivos industriales*, Marcombo S.A, Barcelona.
- (2) **Dillard D. A. (2010):** *Advances in structural adhesive bonding*, Elsevier, U.S.A.
- (3) **Mazumdar S. K. (2002):** *Composites manufacturing: Materials, Product and Process Engineering, Chapter 9: Joining of composite materials*, CRC Press, U.S.A.
- (4) **Schwartz M. (2011):** *Innovations in materials manufacturing, fabrication and environmental safety, Chapter 2: Adhesive bonding*, CRC Press, U.S.A
- (5) **N/A (2002):** *Military Handbook - MIL-HDBK-17-3F: Composite Materials Handbook, Volume 3 - Polymer Matrix Composites Materials Usage, Design, and Analysis*, U.S. Department of Defense, U.S.A.
- (6) **Hull D. (1990):** *An introduction to composite materials*, Cambridge University Press, UK
- (7) **Ashby M.F. and Jones D. (1994):** *Materials 2. An introduction to microstructures, processing and design*, Pergamon, UK

INTERNET DOCUMENTS

- (8) **García Ledesma R. (2013):** *Uniones estructurales mecánicas y adhesivas. Condiciones superficiales y operacionales.* Available in: http://oa.upm.es/22235/1/RICARDO_GARCIA_LEDESMA.pdf. [View:27/4/2015]

(9) **Poveda Martínez S. (2001):** *Acabados superficiales*. Available in: http://ocw.upm.es/expresion-grafica-en-la-ingenieria/ingenieria-grafica-metodologias-de-diseno-para-proyectos/Teoria/LECTURA_COMPLEMENTARIA/MATERIALES/acabados.pdf.

[View:27/4/2015]

(10) **García Gómez A. (2011):** *Influencia del tratamiento superficial con plasma atmosférico en la unión estructural de materiales compuestos (GRP) empleando un adhesivo acrílico*. Available in: <http://www.iit.upcomillas.es/pfc/resumenes/4dea676006a3d.pdf>. [View:15/5/2015]

(11) **Blanes M. (2009):** *Tecnologías limpias en el sector textil. Tratamiento mediante técnicas de plasma para mejorar propiedades en substratos poliméricos*. Available in: http://www.cma.gva.es/comunes.asp/documentos/agenda/cas/62899-MAR%C3%8DA%20BLANES%20COMPANY_AITEX.pdf. [View:15/5/2015]

(12) **Sánchez Matrán F. (2010):** *Uniones adhesivas y sus aplicaciones navales*. Available in: <http://repositorio.bib.upct.es:8080/jspui/handle/10317/1815>. [View:11/5/2015]

(13) **Madrid Vega M. (2000):** *Seminario sobre adhesivos*. Available in: http://ingscientif.yolasite.com/resources/seminario_de_adhesivos.pdf. [View:4/5/2015]

(14) **Conesa Guillén J. (2008):** *Evaluación mecánica de uniones adhesivas de materiales compuestos en la construcción naval*. Available in: <http://repositorio.bib.upct.es:8080/jspui/handle/10317/46>. [View:8/6/2015]

(15) **Anaguano D.P. y Loachamin C.M. (2008):** *Análisis de uniones por adhesión para materiales metálicos*. Available in: <http://bibdigital.epn.edu.ec/handle/15000/2148>. [View:18/5/2015]

(16) Madrid Vega M. (2000): *Tecnología de la adhesión*. Available in:
http://www2.ulpgc.es/hege/almacen/download/7071/7071377/curso_de_adhesivos.pdf.

[View:2/5/2015]

(17) Herrera Santos C. (2013): *Estudio del fallo en uniones adhesivas con materiales compuesto*. Available in:

http://bibing.us.es/proyectos/abreproy/60156/fichero/VOLUMEN+1%252FPFC_CarlosHerrera.pdf. [View:27/4/2015]

(18) Praveengouda P. (2009): *Seminar on laminated composites*. Available in:

<https://es.scribd.com/doc/22702796/SEMINAR-on-Laminated-Composites#scribd> [View: 7/7/2015]

(19) Zubitur M. (2009): *Tema 3: Materiales compuestos de matriz orgánica: interfase y arquitectura*. Available in :

http://cvb.ehu.es/open_course_ware/castellano/tecnicas/materia_comp/tema-3-materiales-compuestos-de-matriz-organica-interfase-y-arquitectura.pdf [View: 6/7/2015]

(20) Parodi P. (2010): *Compuestos laminados*. Available in:

<http://es.scribd.com/doc/37816109/Compuestos-Laminados#scribd> [View: 12/7/2015]

(21) Nettles A. (1994): *Basic Mechanics of Laminated Composite Plates*. Available in:

<http://ntrs.nasa.gov/archive/nasa/casi.ntrs.nasa.gov/19950009349.pdf> [View: 14/7/2015]

IMAGES AND TABLES

Figure 1.1: Seminario sobre adhesivos. (13)

Figure 1.2: Los Adhesivos: Adhesión: Definición y concepto de adhesión Available in:

<http://www.losadhesivos.com/adhesion.html> [View:27/4/2015]

Figures 2.1, 2.2, 2.3, 2.4 y 2.5: Interempresas: *Una aproximación a los adhesivos estructurales de Henkel, la unión óptima para las construcciones industriales:* (https://www.interempresas.net/Cerramientos_y_ventanas/Articulos/55436-La-seleccion-es-la-clave-de-Henkel.html). [View: 7/6/2015]

Figure 2.6, 2.7, 2.8, 2.9, 2.13, 2.14, 2.15: Evaluación mecánica de uniones adhesivas de materiales compuestos en la construcción naval, capítulo 3. (14)

Figures 2.10, 2.11, 2.12: Análisis de uniones por adhesión para materiales metálicos. (15)

Figure 2.16: Composites manufacturing: Materials, Product and Process Engineering, Chapter 9: Joining of composite materials. (3)

Figure 3.1: Olmo M., Nave R. (2014): *Hyperphysics Is Hosted By The Departament Of Physics And Astronomy. La tensión superficial y sus efectos.* Available in: <http://hyperphysics.phy-astr.gsu.edu/hbasees/surten.html>). [View:2/6/2015]

Figure 3.2: Solo Para Ingenieros (2014): *Nuevo método de clasificación celular,* <http://ex-sheffield.org/soloparaingenierosnet/2014/10/17/nuevo-metodo-de-clasificacion-celular/>. [View:7/6/2015]

Figures 3.3, 3.4 y 3.5: Lucas da Silva F.M., Dillard D. A., Blackman R. K. (2012): *Testing adhesive joints.* Available in: <http://download.e-bookshelf.de/download/0000/7534/37/L-X-0000753437-0001828949.XHTML/index.xhtml>. [View:7/6/2015]

Figure 4.1: Composites manufacturing: Materials, Product and Process Engineering, Chapter 9: Joining of composite materials. (3)

Figure 5.1: Metalizadora sifone. *Thermal spray process.* Available in: <http://www.metalizadorasifone.com.ar/proceso.html>. [View:4/6/2015]

Figure 5.2: Corona Brasil (2015). *El tratamiento corona en películas y piezas plásticas.* Available in: <http://www.coronabrasil.com.br/espanhol/tratamiento-filmes-pecas-plasticas.html>. [View:4/6/2015]

Tables 5.1 y 5.2: Innovations in materials manufacturing, fabrication and environmental safety, Chapter 2: Adhesive bonding. (4)

Figure 7.1: Ertug M. O., Suiçmez E. E., Ekici D., Gülbudal K., *Metal and ceramic matrix composites.* Available in: <http://kansu.tripod.com/me451/2.html> [View:22/7/2015]

Figure 7.2: Tecnología de los plásticos (2011): *Clasificación según la forma de los constituyentes.* Available in: <http://tecnologiadelosplasticos.blogspot.it/2011/07/materiales-compuestos.html> [View:9/7/2015]

Figures 7.3, 7.4: Seminar on laminated composites (16)

Figure 8.1: *An introduction to composite materials, chapter 6: Laminate theory* (6)

Figures 9.1, 9.2: Military Handbook - MIL-HDBK-17-3F: Composite Materials Handbook, Volume 3 - Polymer Matrix Composites Materials Usage, Design, and Analysis (5)

Figure 10.1: Home made composites, *What are composites?* Available in: http://www.composites.ugent.be/home_made_composites/what_are_composites.html [View: 9/7/2015]

Figure 10.2: *Basic Mechanics of Laminated Composite Plates.* (21)

Figures 12.1, 12.2, 13.1, 13.2, 13.3, 13.4, 13.5: Military Handbook - MIL-HDBK-17-3F: Composite Materials Handbook, Volume 3 - Polymer Matrix Composites Materials Usage, Design, and Analysis (5)

Figure 15.1: Chatterjee R., *Advanced and future applications of composite fibres in the automotive industry*, Available in: www.slideshare.net/ratnachatnerjee/advanced-future-applications-of-composite-fibres-in-the-automotive-industry [View:14/7/2015]

Figure 15.2: Open Journal of Composite Materials (2014), 4, 47-60, Available in: <http://dx.doi.org/10.4236/ojcm.2014.41006> [View:14/7/2015]

Figure 15.3: Aerospace Materials, Introduction, Available in people.bath.ac.uk/tchm20/1.htm [View15/7/2015]



Tecnología de uniones adhesivas para materiales laminados compuestos

Resumen y traducción del TFG “JOINING ADHESIVE TECHNOLOGY FOR COMPOSITE LAMINATES” del año 2015

Alejandro Gallego Menéndez

Julio 2018

Capítulo 1: Uniones adhesivas

El proceso de unión adhesiva se basa en la aplicación de un adhesivo entre las superficies de uno o varios materiales, produciendo su unión tras el curado del adhesivo. De esta manera, se diferencia entre “adhesivo” y “sustrato”. Para que se produzca esta unión deben darse dos fenómenos:

*La **adhesión**: es un fenómeno basado en fuerzas de atracción y absorción, que depende principalmente del contacto intermolecular y del estado de la superficie del sustrato.*

*La **cohesión**: se basa en las fuerzas de atracción existentes entre partículas adyacentes, las cuales mantienen unidas en la misma sustancia.*

Existen diversas teorías que explican, en función de cada caso concreto, la manera en que se produce el fenómeno de la adhesión:

- *Teoría mecánica: el anclaje del adhesivo en los poros y rugosidades del sustrato produce la unión.*
- *Teoría difusiva: la difusión intermolecular de las superficies crea una zona de transición entre el adhesivo y el sustrato, dando lugar a la unión. Referente a polímeros.*
- *Teoría eléctrica: se forma una doble capa eléctrica al poner en contacto dos materiales de naturaleza diferente, produciendo fuerzas electrostáticas que justifican la adhesión.*
- *Teoría de la adsorción: se generan fuerzas superficiales (de Van Der Waals) en la interfase entre dos materiales diferentes puestos en contacto, teniendo como resultado su adhesión.*

Capítulo 2: Diseño de la junta

Factor principal en cuanto al desempeño del adhesivo, en base a los distintos tipos de esfuerzo a los que pueda ser solicitado. De manera general, para asegurar una buena actuación del adhesivo se deben seguir los siguientes criterios de diseño:

- *La mayor parte del área de pegado debe ser favorable a la resistencia de la unión.*
- *El diseño debe ajustarse a los límites del adhesivo.*
- *El adhesivo debe trabajar en la dirección de máxima resistencia, reduciendo los concentradores de tensión.*
- *El área de pegado debe ser lo mayor posible, ajustándose a ciertos límites.*

- *El adhesivo debe ser capaz de soportar las cargas esperadas.*
- *Las propiedades mecánicas y químicas del adhesivo deben ser compatibles con el sustrato.*
- *Tanto el límite a fatiga como la capacidad de absorción de energía del adhesivo deben conocerse previamente.*

Se hace de vital importancia conocer el tipo y naturaleza de los esfuerzos a los que la unión va a ser sometida antes de elegir el tipo de adhesivo. Normalmente, el adhesivo no estará solicitado bajo un único tipo de esfuerzo, sino que se tendrá una combinación de varios, entre los que se entienden:

Compresión: *generados por fuerzas perpendiculares al plano de la junta que reducen la sección en la dirección que son aplicadas. Producen una distribución de la tensión a lo largo de la unión muy uniforme, por lo que toda su área soporta la misma carga.*

Tracción: *generados por fuerzas perpendiculares al plano de la junta que alargan la sección en la dirección que son aplicadas. Son aceptables mientras las fuerzas aplicadas estén distribuidas uniformemente.*

Cortadura: *producidos por la aplicación de fuerzas externas paralelas a la línea de unión. Los adhesivos suelen mostrar un buen comportamiento ante este tipo de esfuerzos.*

Pelado: *surgen al aplicar esfuerzos de tracción en un extremo de la línea de unión, produciendo un momento flector sobre el sustrato más flexible. Este tipo de esfuerzos suelen ser los más peligrosos, dado que la distribución de la tensión se da de manera muy localizada, teniendo una sección muy corta que soporta la mayor parte del esfuerzo mientras que en el resto de la sección la tensión es casi nula.*

Desgarre: *ocurren de manera similar a los esfuerzos de pelado, pero sin producir deformación en el sustrato, por lo que a pesar de tener una zona localizada de mayor tensión, esta se reparte más uniformemente en el resto de la sección.*

Transitorios: *debidos a un único incremento de la tensión hasta su carga máxima.*

Estáticos o permanentes: *constantes en un periodo de tiempo. Generan un desplazamiento relativo sin necesidad de un incremento en la fuerza aplicada. Este fenómeno se basa en la fluencia, que depende de la temperatura.*

Dinámicos: *pudiendo darse en ciclos regulares (vibración) o irregulares (impactos). Ante este tipo de esfuerzos es vital conocer el límite a fatiga del adhesivo.*

Residuales: *de carácter interno, son debidos principalmente a factores térmicos, afectando tanto al adhesivo como al sustrato.*

El diseño de la unión debe hacerse de manera que el adhesivo trabaje en la dirección de mayor concentración de tensiones, facilitando una buena distribución de las mismas a través del conjunto.

Existen varios tipos de uniones adhesivas, siendo los más comunes:

Uniones frontales: *presentan buena resistencia a esfuerzos de tracción y compresión. Ante esfuerzos aplicados perpendicularmente al eje pueden producirse momentos flectores que den lugar al desgarro de la unión, por lo que se suelen utilizar técnicas de implementación, como el biselado y el uso de cubiertas, para incrementar el área de contacto y la resistencia al desgarro.*

Uniones superpuestas: *diseñadas para soportar cargas axiales, que se traducen en esfuerzos de cortadura sobre la unión, para lo que el adhesivo presenta una muy buena resistencia.*

La resistencia a cargas cortantes en este tipo de unión es directamente proporcional al ancho del solapamiento. Sin embargo, no se produce de manera lineal debido a la concentración de tensiones que se tiene en los extremos de la línea de unión. También se pueden encontrar con concentradores de tensión debidos al desalineamiento de las cargas, que dan lugar a momentos flectores que producen desgarros.

Para aumentar la resistencia en este tipo de uniones se pueden seguir ciertos pasos, como: asegurar cargas alineadas, rigidez en los sustratos (para evitar tensiones de desgarro) y el biselado de los bordes de los sustratos para adaptarse mejor a las sollicitaciones y reducir la aparición de esfuerzos de pelado.

Uniones en T: *muestran baja resistencia a esfuerzos transversales, que producen tensiones de pelado y desgarro. Bajo esfuerzos de compresión puede producirse pandeo. Para mejorar la resistencia en este tipo de uniones se les suelen agregar elementos de refuerzo, que aumentan el área de unión y su rigidez.*

Uniones en esquina: *como en el caso anterior; baja resistencia a esfuerzos transversales y compresores, mejorable mediante el uso de elementos de refuerzo.*

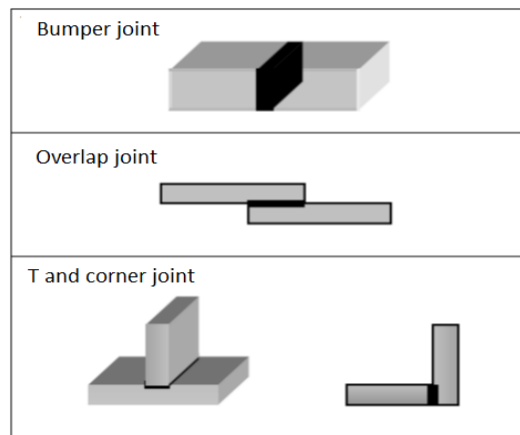

La resistencia de una unión adhesiva depende primeramente de los fenómenos de adhesión y cohesión, de manera que en base a ellos se pueden observar los siguientes modos de fallo:

- *Fallo cohesivo:* cuando la rotura se produce en el seno del propio adhesivo.
- *Fallo adhesivo:* cuando el fallo ocurre en la intercara adhesivo-sustrato.
- *Fallo del sustrato:* la rotura tiene lugar en el sustrato antes de que pueda producirse fallo en el adhesivo o en la intercara.

En lo que compete al diseño de la unión, debe asegurarse que no se produzca el fallo adhesivo.

Capítulo 3: Aspectos a considerar

Se ha comprobado que, a parte del tipo de unión y los estados tensionales de la misma, existen diversos factores que afectan al rendimiento en servicio de las uniones adhesivas. De este modo, también se deberán tener en cuenta para el diseño de la junta:

Energía superficial: energía necesaria para romper los enlaces intermoleculares de una superficie. En el caso de los líquidos equivale a la tensión superficial.

Esta energía juega un papel muy importante en las interacciones entre el adhesivo y el sustrato. Las moléculas en el seno del líquido están sujetas a fuerzas cohesivas, mientras que las moléculas de la capa superficial, al no estar completamente rodeadas de otras, tienden a interactuar de manera más intensa con las vecinas, lo que crea una película externa con cierta tensión.

El sustrato sólido posee una energía superficial mayor que la tensión superficial del adhesivo, atrayendo sus moléculas debido a las fuerzas de adhesión. Esta diferencia de

energías favorece el mojado (“wetting”) de la superficie del sustrato por parte del adhesivo.

Ángulo de contacto: *ángulo que forma una gota del adhesivo con la superficie del sustrato. Indicativo del grado de mojado que produce el líquido en el sólido y de la energía superficial del sustrato.*

Espesor: *referido al adhesivo, aspecto a considerar en cuanto a su tamaño y distribución. Una distribución no uniforme del adhesivo genera tensiones de pelado y reduce la fuerza de adhesión.*

Una capa demasiado espesa de adhesivo incrementa el riesgo de generación de burbujas de aire que actúen de concentradores de tensión, varía las propiedades del curado del adhesivo produciendo tensiones internas e incrementa la tensión en los bordes del adhesivo. Mientras que una capa excesivamente fina puede no ser suficiente para cubrir las porosidades y superficie de contacto de la unión. Para evitar estas situaciones existen métodos de control sobre el espesor, como el uso de aparatos mecánicos, espaciadores, esferas y fibras de vidrio o microfibras mezcladas con el adhesivo.

Curado: *proceso de secado y puesta en funcionamiento del adhesivo. Depende de la presión, tiempo y temperatura.*

La presión durante el curado favorece el mojado, ayudando al adhesivo a alcanzar los huecos y poros del sustrato, y el control del espesor en la línea de unión.

Con tiempos de curado demasiado largos el adhesivo puede secarse antes de conseguir un buen mojado de la superficie de contacto, mientras que para tiempos cortos pueden darse fugas del adhesivo y formación de discontinuidades en su seno (que actúan de concentradores de tensión).

Muchos adhesivos se curan a temperatura ambiente, lo que para ciertas aplicaciones conlleva un tiempo de curado demasiado largo, por lo que se suele aplicar calor para acelerar este proceso. En elementos del mismo material y espesor el calentamiento se produce a la misma velocidad. En ciertos casos, es necesario ajustar el proceso de curado para controlar los ciclos de temperatura de partes con diferente masa o conductividad térmica.

Humedad: *efecto ambiental con repercusiones sobre la resistencia y duración de la unión adhesiva. Las moléculas de agua del ambiente son permeables a la mayoría de los polímeros.*

Cuando se alcanza un valor elevado de la humedad relativa se produce la difusión hacia el adhesivo, favorecido por la aplicación de cargas en la unión. Este proceso puede dar lugar a la plastificación del adhesivo (pérdida de resistencia), la modificación de sus propiedades, al aumento de volumen (que genera tensiones residuales) y al desplazamiento, o incluso reacción, del adhesivo en la intercara sustrato-adhesivo.

Capítulo 4: Tipos de adhesivos

A la hora de clasificar los adhesivos, podemos hacerlo en base al tipo de mezcla o atendiendo a sus propiedades mecánicas.

Por tipo de mezcla:

- *Adhesivos bicomponente mezclados: adhesivos compuestos por dos elementos que requieren un premezclado antes de ser aplicados al sustrato, teniendo un tiempo de vida finito una vez mezclados.*
- *Adhesivos bicomponente sin mezclar: en uno de los sustratos se aplica el adhesivo mientras que en el otro, y en menor cantidad, se aplica un activador. La curación del adhesivo tiene lugar por medio de la reacción entre el adhesivo y su activador.*
- *Adhesivos monocomponente: el adhesivo es el único componente aplicado en el sustrato (no requiere de mezcla previa ni de activador)*

Según sus propiedades mecánicas:

- *Adhesivos rígidos: las uniones producen alta rigidez, a pesar de la baja resistencia en aplicaciones dinámicas o ante esfuerzos de pelado, existen formulaciones más tenaces que les permiten mejorar su respuesta ante estas situaciones. En esta categoría encontramos adhesivos como los anaeróbicos (bicomponente), los cianocrilatos (monocomponente) y los epoxies (bicomponente mas activador o monocomponente)*
- *Adhesivos tenaces: presentan buen comportamiento ante aplicaciones dinámicas y bajo esfuerzos de pelado y/o desgarro generados por la aplicación de cargas. Aquí tendremos los acrílicos (bicomponente).*
- *Adhesivos flexibles: su función principal es la de sellado. También podemos encontrarlos en aplicaciones de juntas estructurales, aumentando la rigidez del conjunto. En este caso tendremos los poliuretanos (bicomponente mas activador o monocomponente) y las siliconas (monocomponente)*

Capítulo 5: Tratamientos superficiales

El proceso de adhesión es un fenómeno superficial, por lo que cualquier sustancia formada en la superficie del sustrato debe ser eliminada para asegurar una buena unión. Este tipo de tratamientos también tienden a favorecer la capacidad de mojado en el sustrato.

Podemos diferenciar los tratamientos superficiales en dos grandes grupos:

Pasivos: *no modifican químicamente la superficie. En este grupo se incluyen:*

- *Desengrasado: elimina grasas y aceites de la superficie del sustrato por medio de distintos solventes, atendiendo al tipo de material del sustrato.*
- *Abrasión mecánica: el principal objetivo de este tipo de tratamiento es el de aumentar la rugosidad (y con ello la superficie de contacto) del sustrato, facilitando así el mojado. También limpia la superficie de contaminantes y partículas sólidas. Existen diversos elementos abrasivos para realizar este proceso (lijas, cepillos de alambre...)*
- *Baños ultrasónicos: se introduce el sustrato en un tanque con solventes, que mediante la aplicación de ultrasonidos, ven su capacidad de actuación mejorada. Proceso de limpieza de alta calidad.*

Activos: *modifican la composición química de la superficie del sustrato. Aquí nos encontramos con:*

- *Tratamientos químicos: aumentan la energía superficial del sustrato y la vida de la unión. Deben ser controlados ya que generan desperdicios tóxicos y pueden modificar las propiedades del material.*
- *Tratamiento de plasma a baja presión: este proceso hace uso de plasma producido por la ionización de un gas cargado positivamente. Limpia la superficie del sustrato y aumenta la rugosidad de la superficie.*
- *Tratamiento por llama: se aplica una llama sobre la superficie del sustrato, produciendo una oxidación parcial que aumenta su energía superficial.*
- *Descarga de corona: es un tratamiento de plasma a baja presión, pero en este caso el plasma se genera por la aplicación de alto voltaje entre dos electrodos metálicos y sólo se usa para sustratos de bajo espesor. Aumenta su energía superficial.*
- *Imprimaciones: sustancias basadas en poliuretanos diluidos y silanes aplicadas al sustrato que protegen la superficie y mejoran la interacción con el adhesivo.*

Capítulo 6: Ventajas y desventajas de los adhesivos

En comparación con otro tipo de mecanismos de unión, los adhesivos presentan una serie de ventajas y desventajas.

Ventajas:

- *Distribución uniforme de tensiones*
- *Mejora de la apariencia final del producto*
- *No sufren de procesos corrosivos*
- *No deforman los sustratos*
- *Reducen el peso del producto final*
- *Reducen el número de componentes total*
- *Alta resistencia al impacto y a la fatiga*
- *Flexibilidad en el diseño*
- *Permite unir materiales diferentes*
- *Uniones rígidas*

Desventajas:

- *Baja resistencia ante esfuerzos de pelado*
- *Requieren de tiempo para el curado*
- *No pueden ser desmontados*
- *Necesidad de preparación de la superficie del sustrato*
- *Sensibles a la degradación ambiental*
- *Pueden requerir herramientas costosas*
- *Pueden producir daños en el medio ambiente*

Capítulo 7: Materiales compuestos

Son aquellos formados por dos o más materiales mutuamente insolubles, de manera que cada uno mantiene su integridad. Combinan las propiedades de los distintos materiales, beneficiándose de sus ventajas y disminuyendo sus inconvenientes, aumentando su capacidad de diseño y sinergia.

Los materiales compuestos están formados por una fase continua y uniforme, llamada matriz, que rodea a una fase discontinua. Esta fase discontinua puede encontrarse en forma de partículas, pequeñas fibras o whiskers y fibras continuas.



La fase discontinua, o fibras, soporta la mayor parte de las cargas, las cuales son propagadas a través de la unión de las dos fases. De esta manera, la estructura y propiedades de la intercara fibra-matriz toman principal relevancia en las propiedades mecánicas y físicas del material compuesto.

La matriz muestra bajas propiedades mecánicas y suele ser de un material dúctil, dado que el trabajo mecánico recae principalmente en las fibras. Las principales funciones de la matriz son mantener la estructura del compuesto y las fibras alineadas, actuar como transmisor de tensiones y proteger las fibras contra la abrasión y la corrosión.

A partir de aquí, el trabajo se centrará en los materiales compuestos de tipo **laminado**. Estos materiales se forman a partir de láminas (o paneles) apilados paralelamente y reforzados con fibras que los proveen de altas resistencias en una dirección principal. Las láminas están formadas por mechas, esteras o telas impregnadas con polímeros, unidas por algún tipo de adhesivo. La lámina es la unidad estructural del compuesto.

Cada lámina está compuesta por su correspondiente fase continua (matriz) y dispersa (fibra). Las propiedades de cada lámina del compuesto se determinarán por los siguientes factores:

- La naturaleza de la fibra
- El material del que está hecha la fibra
- El porcentaje de fibra del compuesto (frente a la matriz)
- La orientación de cada lámina en unos ejes de referencia

En relación a la distribución de las fibras hablaremos de la orientación de las láminas, pudiendo ser:

- **Unidireccionales:** cuando todas las fibras son paralelas a la dirección de la carga aplicada y orientadas solo en una dirección. Las fibras son cubiertas por una capa, permitiendo una transmisión continua de la carga a larga distancia. Proveen de una alta rigidez y concentran menos desperdicios.

- *Bidireccionales: cuando las fibras se distribuyen en dos direcciones perpendiculares en el seno de la lámina.*
- *Multidireccionales: pudiendo estar las fibras orientadas en cualquier dirección y en diferentes direcciones en el resto de láminas.*
- *Tejidos: puede considerarse como un tipo de bidireccional. Las fibras se presentan en forma de tejido textil, agrupadas en varias filas con filamentos cruzados perpendicularmente. Muestran unas propiedades más equilibradas que las unidireccionales y requieren menos tiempo de fabricación que las multidireccionales. Sin embargo, presentan una menor tensión de rotura.*

*Las láminas son unidas entre sí mediante la aplicación de un adhesivo. Las técnicas para realizar este proceso incluyen el **co-curado**, que consiste en unir dos laminas que hayan iniciado el proceso de curación, la **co-uni6n**, que es el curado simultaneo de varias laminas apiladas en la que al menos una est1 totalmente curada y otra sin curar, y la **uni6n secundaria**, que mediante uni6n adhesiva junta dos o mas l1minas pre-curadas de manera que la curaci6n se de en el propio adhesivo.*

Capítulo 8: Suposiciones te6ricas

Para ayudar a comprender el an1lisis final del comportamiento, debido a la complejidad intrínseca de los materiales compuestos, es necesario dar por ciertas unas suposiciones que permitan determinar las propiedades de una lámina. Tales suposiciones son:

Homogeneidad del material: *a pesar de que los materiales compuestos sean inicialmente heterogéneos su an1lisis mecánico se basa en la suposici6n de homogeneidad. Esto es debido a que a nivel microsc6pico muestran una composici6n heterogénea, pero a nivel macrosc6pico se comportan como materiales homogéneos.*

Linealidad material: *no todas las propiedades de los compuestos son lineales, ya que dependen del tipo de muestra, el ensayo y las condiciones experimentales. Sin embargo, para simplificar el an1lisis, suelen considerarse como lineales.*

Anisotropía material: *dada por la variaci6n de las propiedades mecánicas en funci6n de la orientaci6n. Un material ort6tropa tiene hasta 3 ejes ortogonales entre sí de doble simetría rotacional, de tal manera que así se considerarán las láminas.*

Tensiones residuales: *la heterogeneidad microsc6pica implica diferencias en el comportamiento ante la expansi6n térmica de la fibra y la matriz, que generarían*

tensiones residuales en la lámina. De todos modos, se asume que estas tensiones no afectaran a la rigidez del compuesto y que se deforma uniformemente.

Capítulo 9: Teoría de laminación

Para elaborar protocolos de evaluación de tensión y deformación debe considerarse que el espesor de una lámina (de 0,13 mm a 0,25 mm) es menor que las dimensiones del propio plano.

Las premisas de la teoría de placa delgada son:

- Espesor de capa menor que las dimensiones del plano
- Las formas de la superficie de la capa deformada son pequeñas comparadas con toda la unidad de capas
- La dirección normal de la capa no varía con la deformación
- La deflexión vertical no cambia a través del espesor
- La tensión normal a las superficies de la capa no es significativa

A través de un modelo matemático basado en estas premisas se obtiene el campo de desplazamientos.

La teoría de laminación se usa para predecir las tensiones internas, la rigidez y la estabilidad dimensional. La influencia combinada de cargas y momentos en la placa puede ser descrita mediante la siguiente matriz:

$$\begin{bmatrix} N_x \\ N_y \\ N_{xy} \\ M_x \\ M_y \\ M_{xy} \end{bmatrix} = \begin{bmatrix} A_{11} & A_{12} & A_{16} & B_{11} & B_{12} & B_{16} \\ A_{12} & A_{22} & A_{26} & B_{12} & B_{22} & B_{26} \\ A_{16} & A_{26} & A_{66} & B_{16} & B_{26} & B_{66} \\ B_{11} & B_{12} & B_{16} & D_{11} & D_{12} & D_{16} \\ B_{12} & B_{22} & B_{26} & D_{12} & D_{22} & D_{26} \\ B_{16} & B_{26} & B_{66} & D_{16} & D_{26} & D_{66} \end{bmatrix} \begin{bmatrix} \epsilon_x \\ \epsilon_y \\ \epsilon_{xy} \\ \kappa_x \\ \kappa_y \\ \kappa_{xy} \end{bmatrix}$$

En la que: **N** son las cargas, **M** los momentos, **ε** la deformación, **κ** la curvatura, **A_{ij}** la rigidez de elongación y corte, **B_{ij}** la tensión adjunta de elongación-flexión y **D_{ij}** la rigidez flectora y torsional.

Capítulo 10: Secuencia de apilamiento de láminas

Esta secuencia es determinada por la distribución de la orientación de las distintas capas. Las secuencias de apilamiento aumentan con el número de capas orientadas (por ejemplo, un laminado de 8 capas con 4 orientaciones distintas tiene 24 secuencias de apilado diferentes).

La secuencia de apilado debe guiarse por:

- *La resistencia y rigidez en una dirección depende de la orientación de la fibra*
- *Una lámina debe ser siempre simétrica en su plano medio para evitar distorsiones de la estructura debidos a cambios de temperaturas*
- *Las orientaciones más comunes de la fibra de la lámina, en torno a unos ejes arbitrarios, son de 0, 90 y ± 45 grados. La combinación de estas orientaciones garantiza resistencia y rigidez en cualquier dirección.*

La elección de un sistema de coordenadas determina la secuencia de apilado. Partiendo de la dirección de 0°, las rotaciones en sentido horario serán positivas y en sentido anti horario negativas, se eligen la cantidad y los ángulos para el resto de capas dando lugar a la secuencia de apilado.

Capítulo 11: Diseño de materiales compuestos laminados

Los materiales compuestos laminados son muy solicitados debido a su resistencia y rigidez, especialmente en casos en los que sea necesaria una reducción de peso. El objetivo del diseño de estos materiales es obtener un material resistente con una alta capacidad de carga y bajo peso. Por lo que habrá que tener en cuenta:

- *El coste de la materia prima y de fabricación*
- *El volumen de materia que afecte a costes energéticos*
- *Rigidez ante deformación y límites de pandeo*
- *Los coeficientes de expansión térmica y de humedad para mantener la estabilidad dimensional*

A nivel mecánico, el diseño debe considerar:

Efectos ambientales: *la temperatura y la humedad juegan un papel muy importante en la estimación de vida del compuesto.*

Resistencia a la fractura: los materiales compuestos presentan mecanismos de fractura complejos debido a que las grietas pueden producir la rotura de las fibras, el daño de la matriz y la separación de las capas.

Resistencia a la fatiga: depende de las características de la fibra y la matriz, el porcentaje de fibras, el estado de la intercara y la secuencia de apilamiento elegida.

Tensiones interlaminares: debidas a las diferencias en los módulos elásticos y ángulos entre láminas que pueden dar lugar a un fenómeno llamado delaminación.

Resistencia al impacto: depende de la resistencia interlaminar, la secuencia de apilado y la naturaleza del impacto. Los impactos tienden a reducir la resistencia de las láminas y provocan el delaminado del compuesto.

Capítulo 12: Modos de fallo y daño en materiales compuestos laminados

La rotura por tracción de compuestos laminados con capas multidireccionales es precedida por roturas localizadas de fibras y daños en la matriz. El fallo catastrófico ocurre cuando se supera la tensión de rotura en alguna capa.

El modo en que se muestran los fallos depende de las condiciones de carga y las características del material. Los fallos en matriz y fibras ocurren a niveles de tensión por debajo de la resistencia estática, siendo las cargas distribuidas hacia fallos localizados hasta que se produce el daño crítico.

En la siguiente imagen podemos encontrar los diferentes mecanismos de fractura por tracción tanto a nivel microscópico como a nivel macroscópico:

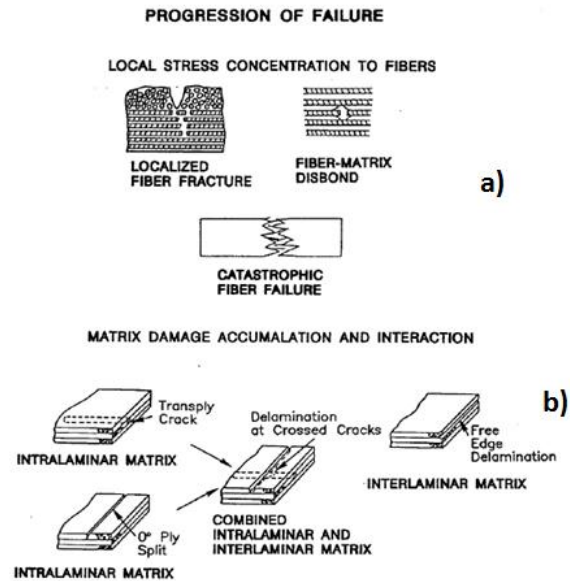

En cuanto a la compresión, su resistencia está relacionada con la respuesta local de grupos individuales de capas. La resistencia y la estabilidad local de capas alineadas en la dirección de la carga axial determinarán el fallo final.

Cuando existe daño en la matriz la reacción local de la combinación de grupos de capas afecta a la resistencia de compresión. El riesgo a pandeo se ve reducido cuando las láminas críticas se sitúan en los extremos de la secuencia de apilamiento.

En función de la combinación fibra-matriz de cada lámina pueden darse fallos locales como combinación de fallos en la fibra (cizallamiento, retorcimiento o flexión) y separación de la matriz (blanda).

En la imagen inferior encontramos 3 tipos diferentes de fallo por compresión:

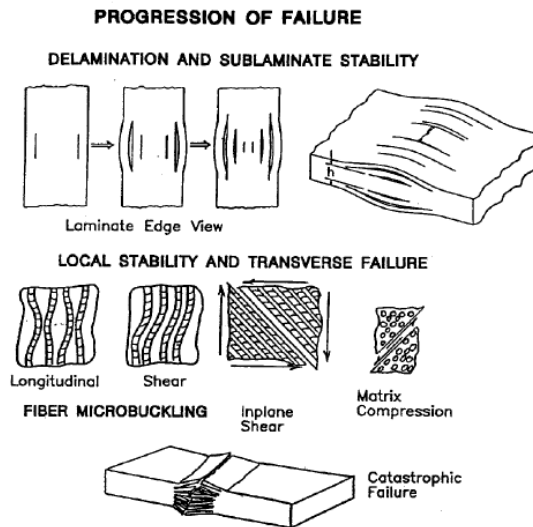

Capítulo 13: Pandeo y crippling

Pandeo: ocurre bajo esfuerzos de compresión y da lugar a desplazamientos fuera del plano. Es un fenómeno de sobra conocido y en el TFG se incluyen las ecuaciones y representaciones de diversas formas en las que se puede presentar para las láminas.

Postpandeo: es la habilidad de soportar cargas de pandeo de un miembro compresivo. El rango de actuación cubre desde el pandeo inicial hasta la carga máxima que produce el fallo, como la delaminación en el extremo libre del elemento compresor o la separación del refuerzo de la placa.

Crippling: debido también a esfuerzos de compresión, es el modo de fallo en el que la sección transversal de un refuerzo sufre una distorsión en el plano sin que se produzca rotación en la sección vertical. Da lugar a cambios bruscos en el ángulo de la sección.

Capítulo 14: Consideraciones generales

Tensión residual: las tensiones de curado no producen variaciones apreciables en el laminado dado que son controladas por las fibras. De todos modos, en ciertas aplicaciones (sobre todo en resinas) estas tensiones residuales sí que pueden ser mayores que el límite de resistencia a rotura, produciendo microagrietamientos en el seno del elemento antes de la aplicación de la carga.

Efectos en el espesor: las diferencias de espesor que se pueden apreciar en láminas del mismo compuesto suelen explicarse por las tensiones residuales generadas en su procesamiento. En el caso de láminas con el mismo espesor pueden producir diferencias en su comportamiento. Estas tensiones pueden afectar a las propiedades del material y generar huecos, delaminación y microgrietas. También pueden ser producidas por el impacto ambiental debido a las condiciones de temperatura y humedad.

Efectos en el borde: el estado tensional que se da entre láminas de distinta orientación se vuelve muy complejo en los bordes del laminado. En ciertas ocasiones, el fallo surge como consecuencia de la delaminación en zonas con fuertes tensiones interlaminares producidas por pequeñas fuerzas. Los efectos de estas tensiones en los bordes de la lámina pueden ser suficientes para reducir su resistencia.

Efectos en las propiedades tensionales transversales: las propiedades de resistencia transversal son mayores en el conjunto laminado que en la lámina. Cuando disminuyen las posibilidades de fallo por tensiones transversales se puede apreciar una sensibilidad en determinados puntos que suelen pasar inadvertidos en la sección cruzada. Las grietas iniciales, al comenzar su expansión, chocan contra las fibras que están dispuestas en direcciones perpendiculares, siendo frenadas por estas.

Efectos de la secuencia de apilamiento: el aumento de las posibilidades de apilamiento con el mayor número de láminas facilita la optimización de la respuesta del compuesto. Esta secuencia afecta a las propiedades estructurales del compuesto (rigidez, estabilidad, resistencia...) y su relación varía con cada propiedad, por lo que deberá ser elegida acorde a la aplicación específica.

Capítulo 15: Aplicaciones de materiales laminados compuestos

Este tipo de materiales son principalmente diseñados para aplicaciones estructurales en las industrias aeronáuticas, automovilísticas y marinas. Ofrecen altos ratios de rigidez- peso y resistencia- peso en relación a los metales usados tradicionalmente. Gracias a las innovaciones y la mejora en los procesos de manufacturación el coste de estos materiales se ha reducido con el tiempo y ha permitido hacerlos competitivos y accesibles a un mayor número de sectores.

En el diseño del automóvil, han permitido crear estructuras más ligeras que reducen el gasto y las emisiones de combustible y presentan buenas respuestas al impacto. Podemos



encontrarlos en distintas aplicaciones, como en termoplásticos, en laminados y en estructuras reforzadas con fibras.

El uso de materiales compuestos en aplicaciones aeronáuticas se ha incrementado mucho en los últimos años. Las compañías han ido incorporando progresivamente cada vez más partes fabricadas con materiales compuestos, pasando de tener solo un par de elementos de avión en la década de los 70 hasta ver como están presentes en la mayoría de sus partes a día de hoy, como en el caso del Boeing 787, cuyo cuerpo está constituido al 50% de materiales compuestos laminados de carbono.

En cuanto a las aplicaciones marítimas, comenzaron con el uso de polímero reforzado con fibra poco después de la Segunda Guerra Mundial, conducidos por la necesidad de construir barcos más ligeros, fuertes, resistentes a la corrosión y duraderos. A día de hoy la mayoría de naves se construye con compuestos de poliéster reforzado con cristal. Materiales compuestos también han sido utilizados en el sonar de los submarinos debido a su elevada transparencia acústica.