

## RESEARCH ARTICLE

# New Bidirectional Heavy Device for Launching Bridges Based on Inverted Caterpillar Mechanism

Mar Alonso-Martinez<sup>1,\*</sup>, Juan J. del Coz-Diaz<sup>1</sup>, Daniel Castro-Fresno<sup>2</sup> and Antonio Navarro-Manso<sup>3</sup>

<sup>1</sup>Department of Construction and Manufacturing, EPI Gijón, University of Oviedo, 33204 Gijon, Spain; <sup>2</sup>GITECO Research Group, ETSICCP, University of Cantabria, 39005 Santander, Spain; <sup>3</sup>Department of Energy, University of Oviedo, 33204 Gijon, Spain

**Abstract: Background:** This patent is based on the combination of caterpillar mechanisms and conveyors. Caterpillar tracks support heavy loads and adapt this support according to the ground conditions. Conveyors displace distributed loads continuously and bidirectionally using the force of friction. This paper describes a revision of previous patents related to this innovative design.

**Objective:** This paper presents an innovative patent to continuously displace heavy structures safely. The mechanism was patented in 2011 as Spanish Patent ES 2367737. The combination of these mechanisms provides the design of this patent to displace heavy structures continuously and bidirectionally, while adapting to the deflection of the structures.

**Method:** The most important elements of this patent are detailed in the paper. The most innovative component is the load compensation system, which increases the safety of the displacement of heavy structures. This system controls the load applied on the mechanism, and the displacement can be stopped before the collapse of the heavy structure.

**Results:** An application of the patent for launching bridges using the Incremental Launching Method is presented. This mechanism is used to displace heavy structures using the force of friction.

**Conclusion:** The patented mechanism is an original contribution for the displacement of heavy structures continuously and bidirectionally. The patent can be used to launch bridges, improving the efficiency, sustainability, and safety of current systems.

**Keywords:** Caterpillar mechanism, construction, conveyors, friction force, heavy structures, launching bridges.

## 1. INTRODUCTION

The Launching Method (LM) is a common technique used in bridge construction. This methodology displaces the bridge structure to its final position using the force of friction. Bridge structures are prefabricated and then launched by means of such systems. LM is mainly used for building large-span bridges or high bridges, as well as in difficult landscapes or protected environments [1, 2].

LM was developed in the 19<sup>th</sup> century for launching steel bridges. This technique has been improved over the centuries. In the 20<sup>th</sup> century, LM was optimized and the Incremental Launching Method (ILM) was developed [1, 2].

Currently, the main systems for launching bridges are the following:

- Sliding devices, which hold the bridge structure and move it forward using rollers on rails, frictionless surfaces, etc.
- Carriers, which move the bridge structure on trailers.
- Pontoons, which move the bridge structure over water.
- Launching jacks, which move the prefabricated structure forward using the force of friction.
- Tow systems with bars or cables, which use hydraulic jacks to pull the structure.

Caterpillar tracks are mechanisms used as a means of transport. They are able to support heavy loads and adapt to irregular ground surfaces. Caterpillar tracks are used in vehicles such as construction machinery, military vehicles, snow vehicles, and so on [3-5]. These mechanisms have been improved by various advances over the years. For example, European Patent EP0974510 [6] describes a crawler track vehicle with improved vibration behavior. The inventors behind this patent increased the mass and included new

\*Address correspondence to this author at the Construction and Manufacturing Department, Polytechnique Engineering School, University of Oviedo, Campus de Viesques, Gijón, Asturias, Spain; Tel: +34985182353; E-mail: [mar@constru.uniovi.es](mailto:mar@constru.uniovi.es)

damping elements in the chassis. European Patent EP0974510 [6] was developed to improve the behavior of military vehicles.

Displacement by friction using conveyors is used in several industrial applications [7]. A load is displaced by means of the friction coefficient between two surfaces, with no relative movement between elements in contact. Conveyors are used in several industrial fields, such as for the transport of raw materials for mining or to move materials and manufactured products in industrial facilities. The main aim of conveyors is continuously to move material over large distances. European Patent EP2326579 [8] presents a variable length conveyor to displace material by the force of friction. This variable length system increases the operating life of the mechanism in abrasive environments. However, this system cannot move heavy loads.

Another civil engineering application of the displacement of heavy structures is the ILM for bridges [1, 2, 9]. ILM uses pairs of hydraulic jacks. A pair of vertical jacks is used to create vertical pressure between the bridge structure and the mechanism, and a pair of horizontal jacks is used to displace the bridge structure. This system is not a continuous movement because of the length of the piston. ILM has launched bridges with spans longer than 70m. However, this method has significant disadvantages such as the non-continuous displacement of the structure, the need for auxiliary devices, the lengthy dead time during launching, and the maximum speed limit [1, 9, 10].

Korean patent KR20050009891 [11] describes a launching method using hydraulic jacks. This system does not provide continuous displacement because each launch is limited by the length of the jacks. This problem is solved by French patent FR2437466 [12], in which a pair of chains moves sheets with a low coefficient of friction between the bridge structure and the mechanism. This patent presents a system to reduce the friction between the bridge structure and the pile supports and to guide the structure. However, it is not able to provide movement by itself. Another system, presented in patent WO0073589 [13], has a mechanism to support dynamic loads but does not move the structure. The mechanism of this patent needs auxiliary equipment to displace the bridge structure. This system has other disadvantages such as the need for manual replacement of the support sheets.

In summary, several problems have been found in current systems to displace heavy structures:

- Caterpillar tracks are effective for moving vehicles over irregular ground, but do not work at a fixed point.
- Industrial conveyors displace heavy loads in a fixed place, but the loads must be distributed.
- Current systems to launch bridges support heavy structures, but have lengthy dead times because of the stroke of the hydraulic jacks. Furthermore, these mechanisms are slow and they do not have a safety system to stop launching before the failure of the structure.

For these reasons, the authors of this paper developed patent ES2367737 (also published as WO2013001114 in 2013) [14]. The mechanism presented in this paper provides

continuous displacement of heavy structures without the use of auxiliary elements, increases the speed of the launching process, and includes a safety system to control the load during the movement of the structure. The new mechanism is safer, more sustainable, and more efficient than current systems.

## HEADINGS OF MATERIALS AND METHODS

### 2. DESCRIPTION OF THE PATENT

This patent is an innovative solution for the civil construction field, enabling heavy structures to be moved using the force of friction. It is a new mechanism for launching bridges more safely, sustainably, and economically than in traditional systems. The mechanism described in this patent satisfies the following requirements.

- It must support heavy loads such as the weight of a bridge structure.
- It must support a wide range of vertical loads in order to launch many different types of structures. A minimum normal load is needed to move the structures by means of the force of friction. A smaller load corresponds to a larger friction coefficient, so the materials in contact between the structures and the mechanism are very important. This patent includes a new mechanism to change the support sheets depending on the material of the structure. In this way, the most appropriate combination of materials ensures a suitable friction coefficient.
- It must adapt to the deflection of the structure on the supports of the mechanism. For metallic structures, the deformation of the structure can reduce the surface area in contact, avoiding movement. To ensure adequate contact between the structure and the mechanism, the adaptation between both elements is essential.
- Displacement of the heavy structure must be continuous with no dead time. Forward and backward displacement must be possible without auxiliary devices. In this way, the efficiency of the process is greatly increased.
- It must increase the speed of displacement. Currently, the speed of the launching process of bridges is around 12 m/h. Increasing the launching speed reduces the operation time of the whole process. This reduces launching time saves money and increases the safety of the construction.
- It must reduce the risks of the launching method. Collapses have occurred during bridge launching operations, causing the death of workers. Most of these could have been avoided using safety controls during the launching process. The new mechanism must include safety systems to detect overloads during the launching procedure in order to stop before the structure collapses.

To satisfy these requirements and solve the main problems of current systems, this patent includes the following characteristics:

- The *movement is continuous* and dead times are eliminated. Furthermore, the *movement is bidirectional*, so the new device can go forward or backward without auxiliary systems.

- **The design** of the new mechanism is **compact and very resistant**, because the load applied to the structure during launching is very heavy. The maximum vertical load that can be displaced by this new patent is  $1.5 \cdot 10^6$  kg.
- The patented mechanism **displaces different types** of structures **and different materials**.
- The **lineal velocity is limited by the structure** to be displaced instead of by the mechanism. For example, for the launching of bridge structures, the speed can be increased using this patent without safety risks.
- The **location of this new mechanism** is very important in organizing the building site and other elements of the construction. In this case, the **design** of the mechanism is **compact and modular** to allow movement from one construction site to another. For launching bridges, this mechanism is located in the abutment of the bridge and moves the bridge structure from that position.
- The **sustainability** of this new design is very important for the construction field. This mechanism can be **reused** in different constructions. In this way, the efficiency and profitability of the construction are increased and the amount of **residual material is reduced**. These are significant advantages over traditional construction methods.

A description of the design of the patented mechanism is included in this manuscript. The mechanism design is shown in Figs. (1-5).

The heavy structure is supported by support sheets (1). These support sheets are located on the support links (2), which are joined by bolts (3). These bolts also connect the links of the tensile chain (4). At the extremes of these bolts, there are rollers (5) that are geared in the gearwheel (6). The gearwheels are rotated by a shaft (7). A tensioner (8) controls the stress of the tensile track. Two motors (19) activate the mechanism. These motors are supported by bearing supports (18) in order to be fitted to the frame (16). The frame has a hole (16a) to access the interior of the mechanism for maintenance or repairs. The frame has two sheets at the top (17) to protect the mechanism from external factors during operation. The frame is fixed to the ground using high resistance bolts (20). The system includes two auxiliary systems, which improve the operation of the mechanism. One is the anti-friction system (28) to ease the displacement between the elements and the frame. The other is the load compensation system (26), which adapts the support links to the deformed shape of the structure.

## RESULTS AND DISCUSSION

### 3. APPLICATION OF THE MECHANISM: LAUNCHING BRIDGES

The patent presented in this paper can be used as an innovative mechanism for launching bridges. This application reduces the disadvantages and improves the efficiency and sustainability of current systems. Current launching methods have the following disadvantages:

- The normal load applied on the mechanism for launching bridges must be controlled accurately to avoid the collapse of the bridge structure.
- Current mechanisms cannot be used for bridge structures made of different kinds of materials or geometries.

- The systems are not continuous because of the retraction of hydraulic jacks.
- Many auxiliary devices are needed to move the structure backwards.
- Lengthy dead times are added to the construction time by the retraction of the hydraulic jacks and the necessary auxiliary operations.

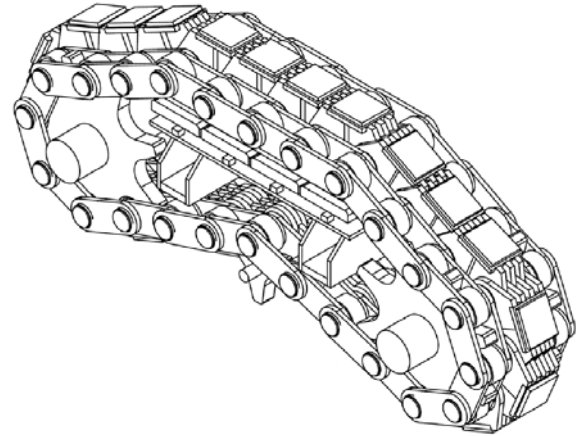

Fig. (1). Design of new mechanism to displace heavy structures.

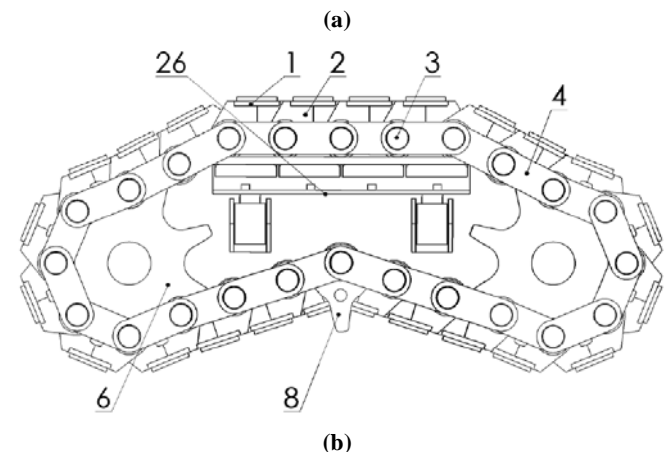
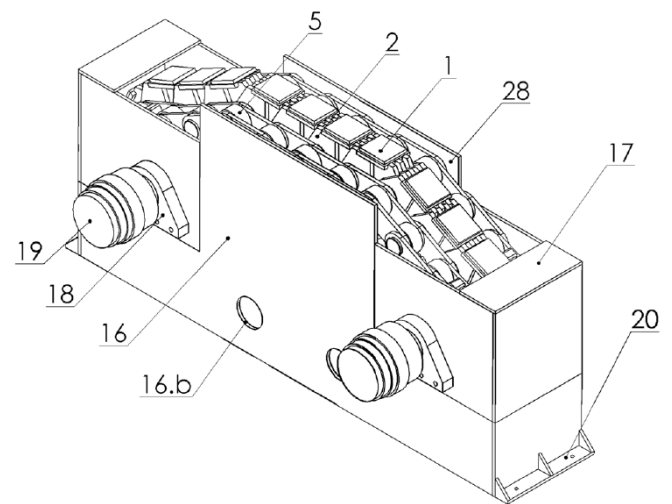

Fig. (2). Description of main elements.

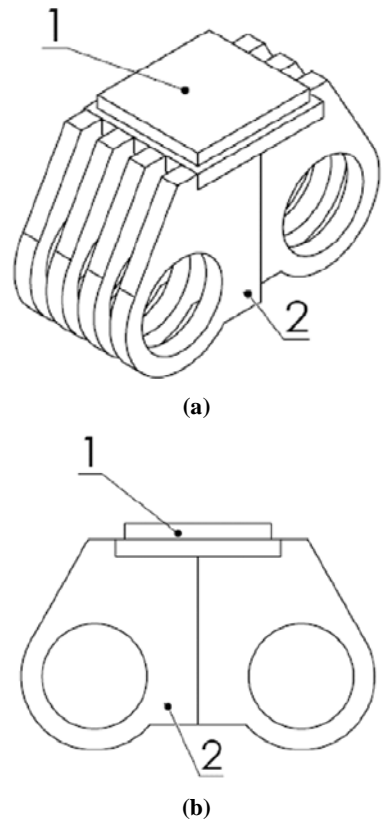

Fig. (3). Support links of the mechanism (2) and neoprene support sheets (1).

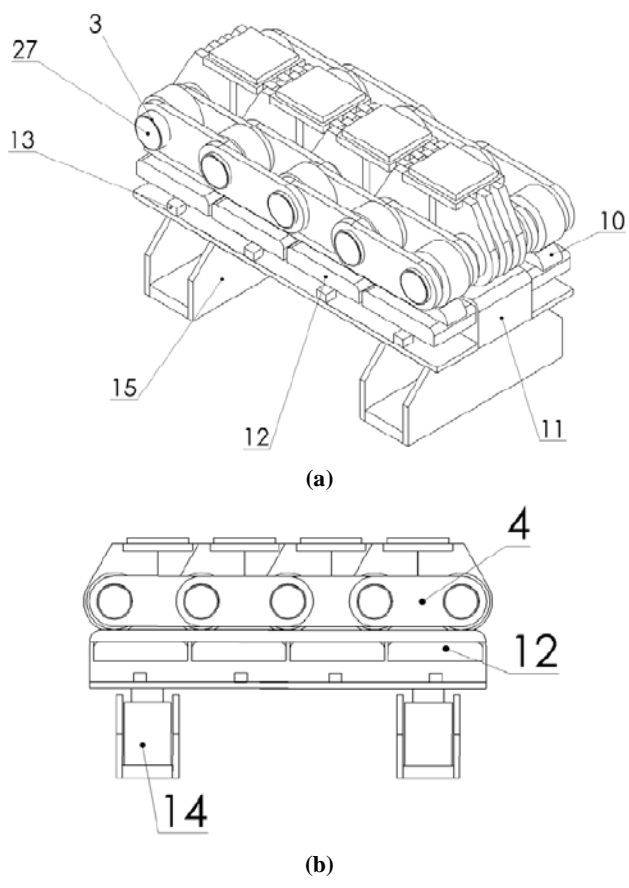
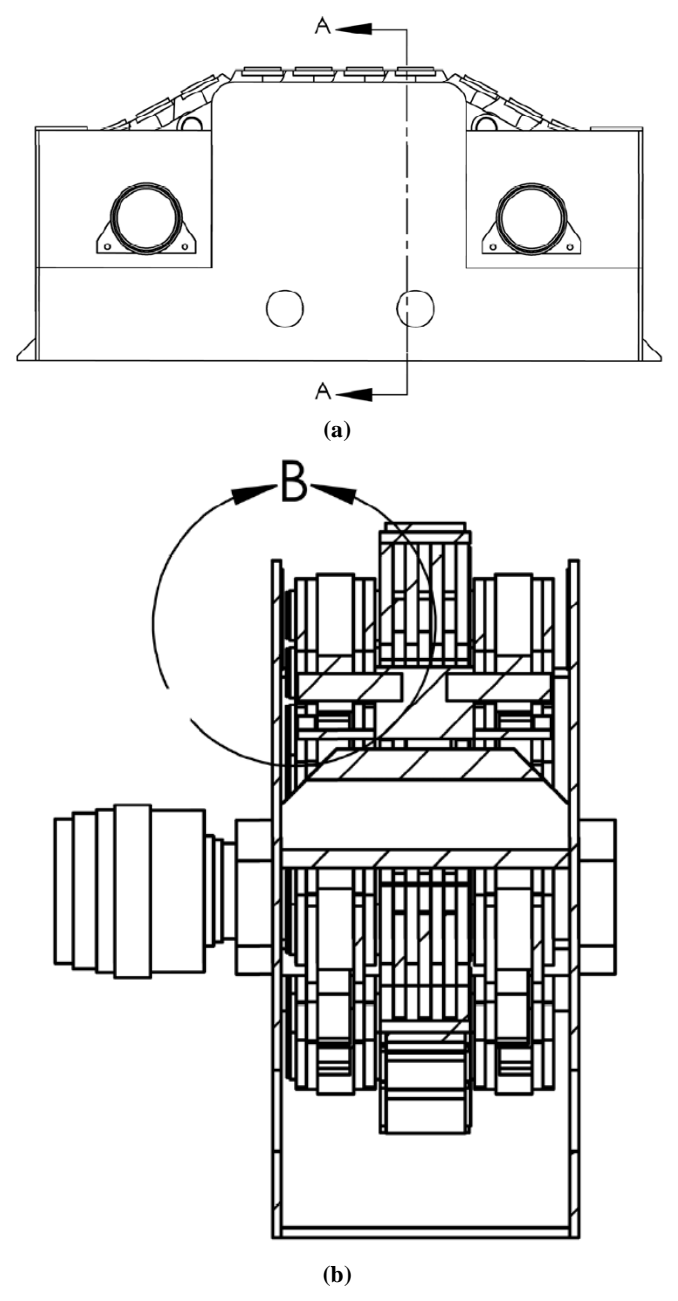
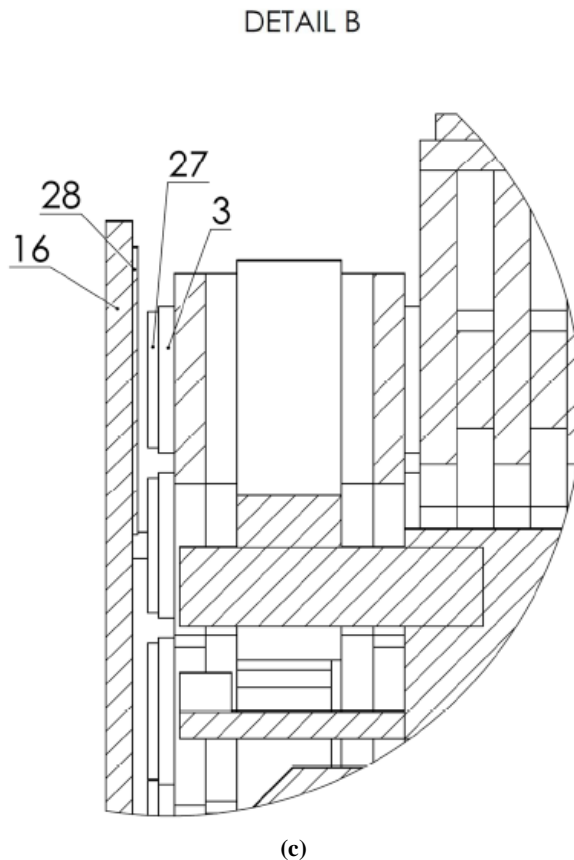

Fig. (4). Load compensation system of the launching mechanism.

This paper describes an application of the mechanism of this patent for launching bridges with a span of over 150 m. In this application, the launching process is carried out using four mechanisms placed under the bridge webs in pairs. The maximum normal load is up to  $3 \cdot 10^7 \text{ N}$  and the launching speed is about 20m/h. The elements of this patent have been designed, calculated, and improved by the inventors [15, 16].

The new mechanism provides continuous forward and backward displacement, following the relevant safety procedure. The frictional behavior between the bridge structure and the launching mechanism is very important. This patent includes support links where the support sheets are located. These sheets are interchangeable in order to use the appropriate material for different bridge structure materials. In this application, a steel bridge structure is combined with neoprene sheets to obtain a suitable coefficient of friction under the specified load and speed conditions.





**Fig. (5).** Frictionless system: (a) Front view of the mechanism; (b) Section view of the mechanism; (c) Frictionless system details.

The patented mechanism also includes a load compensation system that adapts the launching mechanism to the deflection of the bridge structure [14]. Furthermore, this load compensation system measures the normal load applied on the mechanism during the launching process in real time. In this way, the displacement of the bridge structure can be stopped if an overload is detected. This is a significant improvement in the safety of the launching procedures, because risks are minimized and catastrophic accidents can be avoided. The authors of this paper studied the performance of this system using the Finite Element Method (FEM) [15].

The load compensation system is composed of several elements, which are described in this paper. Cantilever beams with variable stiffness (12) are embedded in a central beam (11) to support the roller rail (10), where the rollers of the chain roll. The whole system is supported by hydraulic jacks (14) that increase or decrease the slope of the launch. The cantilever beams adapt the support links to the deformation of the bridge structure. The load compensation system is fixed to the frame using a U-shaped structure (15). To determine the load applied on the mechanism, safety sensors (13) take measurements of the deflection of the cantilever beam (12).

Finally, a thin sheet of frictionless material is included on both sides of the bolts (27). These frictionless sheets minimize the force of friction between the bolts and frame in case lateral movements occur. On the internal side of the frame, a

sheet of anti-wear material reduces the wear of the frictionless sheets fixed in the bolts. Horizontal loads do not usually occur, but this system improves the efficiency of the displacement by reducing extra friction in some elements.

#### 4. CURRENT & FUTURE DEVELOPMENTS

The following future works are planned to improve the design presented in this paper.

Analysis of the design of the mechanism using FEM.

Manufacture of a small-scale prototype to study the real behavior of this recent patent.

Testing the mechanism and the efficiency of the load compensation system to ensure safe displacement.

Optimization of the patent to account for tests done on the prototype.

#### CONCLUSION

This patent displaces heavy structures such as bridges in both the forward and backward directions without using auxiliary elements. The mechanism of this patent provides continuous movement with no dead time. The support links combined with the load compensation system adapts the mechanism to the bridge deflection. Furthermore, the load compensation system detects overloads applied on the mechanism and stops the launch before the structure collapses. This mechanism is able to safely displace heavy structures for large-span bridges.

This patent reduces the dead time of the launching procedure, increasing the efficiency and sustainability of ILM. This patent reduces the risks of the movement of heavy structures using position sensors that detect overloads on the mechanism.

This patent is compact and modular, so it can be used alone or combined.

This patent provides different launching speeds and can be used for different types of bridge structures: spans up to 150 m, straight or curved structures, and with or without slope.

#### CONSENT FOR PUBLICATION

Not applicable.

#### CONFLICT OF INTEREST

The authors declare no conflict of interest, financial or otherwise.

#### CONFLICT OF INTEREST

The authors confirm that the content of this article has no conflict of interest.

#### ACKNOWLEDGEMENTS

The authors would like to acknowledge the help of the Spanish Ministry of Economics and Competitiveness through the Research Project ALCANZA, IPT-380000-2010-012 INNPACTO program.

Furthermore, the authors are grateful to project GRUPIN14-004, co-financed with FEDER funds.

## REFERENCES

- [1] Rosignoli M. *Bridge Launching*. 2<sup>nd</sup> ed. Thomas Telford: Italy 2002.
- [2] VSL International LTD. *The incremental launching method in prestressed concrete bridge construction*. Gerber AG, Schwarzenburg: Bern, Switzerland 1977.
- [3] Wong JY. *Theory of ground vehicles*. 2<sup>nd</sup> ed. John Wiley and Sons, Inc.: New York, USA 1993.
- [4] Popp K, Schiehlen W. *Ground vehicle dynamics*. Springer-Verlag Berlin Heidelberg: Stuttgart, Germany, 2010.
- [5] Muro T, O'Brien J. *Terramechanics. Land locomotion mechanics*. Taylor and Francis: Abingdon, UK 2004.
- [6] Zonak, A., Boettcher, R *Crawler track vehicle*. EP0974510 (1998).
- [7] López RA. *Cintas transportadoras*. CIE Dossat: Madrid, Spain 2002. Spanish Language
- [8] Lapeyre, R.S., Leblanc, P.M., Guernsey, K.W. *Living-hinge conveyor belt*. EP2326579 (2008).
- [9] LaViolette M, Wipf T, Lee Y-S, Bigelow J, Phares B. *Bridge construction practices using incremental launching*. American Association of State Highway and Transportation Officials (AASHTO): Iowa, USA 2007.
- [10] Wardhana K, Hadipriono FC. *Analysis of recent bridge failures in the United States*. *J Perform Constr Facil* 2003; 17: 144-150.
- [11] Hyeong, C.K., Joon, J.E., Nyoun, K.C., Yeop, S.S. *Launching system to push an upper girder in a bridge to be constructed through an incremental launching method by including a molding place*. KR20050009891 (2005).
- [12] Bauges, M.J.G. *Rhythmic sliding bearings forwarding bridge superstructure - have friction reducing plates on chain links running over paired rollers*. FR2437466 (1980).
- [13] Carlos,D.L.F. *Device for supporting a moving load*. WO0073589 (2000).
- [14] Castro-Fresno, D., del Coz Diaz, J.J., Navarro, M.A., Alonso-Martinez, M. *Device for continuous movement of structures*. ES2367737 (2011).
- [15] Alonso-Martinez M, del Coz Díaz JJ, Navarro-Manso A. Castro-Fresno D. *Bridge-structure interaction analysis of a new bidirectional and continuous launching bridge mechanism*. *Eng Struct* 2014; 59: 298-307.
- [16] Alonso-Martínez A, del Coz Díaz JJ, Castro-Fresno D, Navarro-Manso A. *New mechanism for continuous and bidirectional displacement of heavy structures: Design and analysis*. *Autom Constr* 2014; 44: 47-55.