

SEPTIEMBRE 2014

A CRITICAL ANALYSIS OF THE CENTIPEDE GAME



Universidad de Oviedo

Facultad de Economía y Empresa

Trabajo Fin de Máster en Economía: Instrumentos del Análisis Económico

BERNARDO GARCÍA POLA

(University of Oviedo)

TUTORES: NAGORE IRIBERRI AND JAROMIR KOVARIK

(University of the Basque Country)

Abstract

The centipede game is one of the clearest examples of the paradox of backward induction. Such paradox happens when, in a sequential game, the unique perfect Nash equilibrium prediction implies a very counterintuitive play. Experimental tests of the centipede games confirm this contradiction: individuals do not follow the subgame perfect equilibrium prediction.

Previous researchers have used examples of the centipede game to give possible explanations to the behavior of people in order to solve the paradox, but they only have applied it with very particular variations of the centipede game, and without providing an exhaustive analysis of the game.

This paper revisits the centipede game. First, we propose a definition of the game. Second, we show that the payoffs can allow for increasing, decreasing or constant pattern over the sequential nodes. Third, we show the subgame perfect equilibrium prediction and other alternative solutions. Fourth, we propose how the different payoff patterns can be exploited in order to distinguish between alternative models that have been proposed in order to explain the non-equilibrium behavior observed in the laboratory.

1 Introduction

Firstly, we need to understand what a centipede game is and how it is represented. The first appearance of a centipede game is given by Rosenthal (1981). The extensive/form representation of the game can be found in Figure 1.

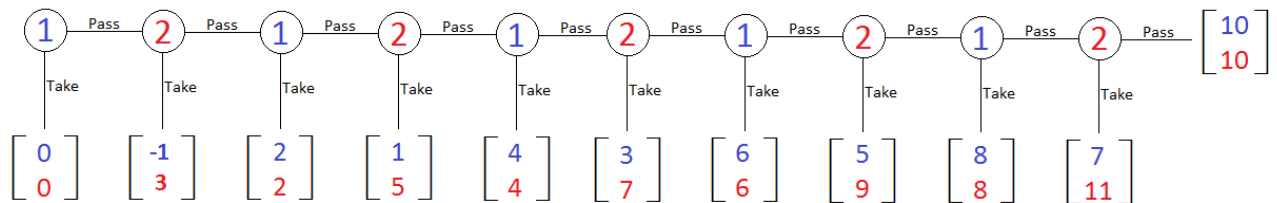

[Fig.1. Rosenthal centipede game]

It is a sequential game, decisions by players are not made simultaneously, but one player goes after the other. Each circle with a number is a decision node; the number in each node represents which player, 1 or 2, chooses an action out of two options, take or pass. The numbers in brackets are the payoffs of each possible end of the game. The first/upper number is the payoff of player 1, and the second/lower the payoff of player 2. In words, the game goes as follows. The first node is for the player 1, so he starts playing. If he chooses “take” the game is finished, and both players receive 0; if player 1 chooses “pass”, the outcome depends on the decision of player 2, who can also “take” and finish the game (where player 2 receives 3 and player 1 obtains -1) or “pass” and give the player 1 an option to choose again.

The subgame perfect equilibrium of the game is to play “take” in every decision node¹. By backward induction, in the last node the second player would choose “take”, because 11 is a higher payoff than 10. In the previous node, the first player would also “take” for the same reason, comparing 8 with 7. Given the payoff structure of the sequential game, this reasoning applies to every node, being “always take” the subgame equilibrium strategy, which makes (0,0) the equilibrium payoff.

This prediction is counterintuitive.

¹ We assume, as it is standard in the literature, that individuals have selfish preferences and that they are utility maximizers.

First, the predicted outcome is not efficient. In this case, every other payoff combination in the game, except for $(-1,3)$, is Pareto dominating, such that both players are better off.

Second, and related to the equilibrium payoffs being non-efficient, a player has incentives to continue playing, in order to obtain higher payoffs. But, at the same time, he has incentives to finish the game before the opponent does, because the outcome will be higher. Basically, a player will prefer moving forward the game, but also being the one who stops first. If a race of who stop first starts, it will result in stopping in the first node. However, the experimental results show that people rarely stop the game in the initial stages (see Section 2 for a review).

In this paper we review both the theoretical and experimental literature dealing with the centipede game. Later we propose a general definition of the game and its implications. We will see that only a few variations of the game have been explored, (increasing and constant sum), but there exist possibilities not considered by the literature so far. Finally, we show the potential these different centipede games provide to identify the alternative behavioral models that could explain the observed non-equilibrium behavior in the centipede game.

2 Literature Review

Rosenthal presented the centipede game for the first time in 1981. [Fig. 1. Rosenthal centipede game]. This paper is about how we should treat perfect information sequential games. He says we should treat them like one-player decision problems, giving subject probabilities to the possible outcomes in each node. He presents the centipede game just as an example of the difficulty that we do not know how the other will behave, even if both have chance to gain more qualitative outcome moving along the game.

Note that this centipede game has 10 nodes and the payoffs sum increases in a linear way. Rosenthal gave an approach to the idea of possible reasoning: if you

believe that your opponent will deviate from the subgame perfect Nash equilibrium, maybe it is not the optimal strategy to stop in your first decision node.

Megiddo (1986) introduce a shorter centipede game with an exponentially increasing sum, called “Share or quit”.

The name of the game (centipede) is due to Binmore (1987), who designed a 100-moves version of the game.

Aumman (1988) showed a “Share or quit” version, with a few modifications. There are two mounds of money. In the decision node a player can choose the bigger one and give the other to the opponent, or pass the mounds. Every time the mounds are passed to the other player, they are multiplied by a fixed number. They start with a pot of 10,50\$, in two mounds, 10\$ and 0,50\$. Each time they pass the mounts are multiplied by 10. The game has 6 decision nodes, 3 for each player. It is a exponential increasing game then.

Aumann (1992) showed how even with a high grade of common knowledge of rationality (but not total) it is possible not to end in the very first node.

McKelvey and Palfrey (1992) were pioneers in test the centipede game experimentally. They used a modest version of Aumann’s game in two versions, 4 nodes and 6 nodes. The initial Pot was 0,50\$, in mounds of 0,10\$ and 0,40\$. The stacks were multiplied by 2 each node.

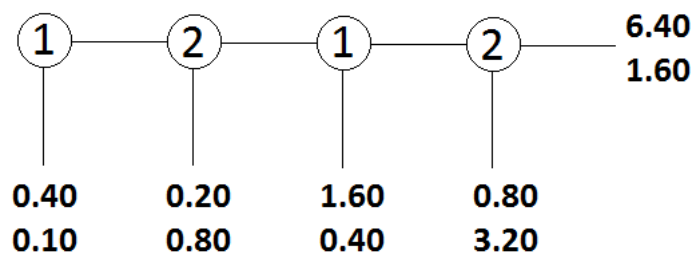

[Fig. 2. Modest version of Aumann’s in 4 nodes]

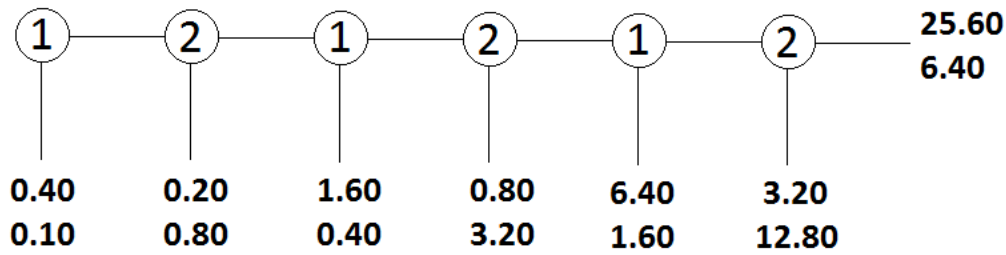

[Fig. 3. Modest version of Aumann's in 6 nodes]

The reason to use this game, is that the paradox is more obvious in an exponential increasing centipede game. But they reduce the payoffs because the amounts of money needed in the final outcomes in the Aumann's version were too high to make a real experiment.

They observed that the SPE prediction was, indeed, a bad prediction. People behaved more like the intuition suggested. 37 of 662 finished in the subgame perfect equilibrium outcome. 23 of 662 reach the final node of the game. Most of the people ended in the middle of the game, and more often in the outcomes closer to the end.

They offer some reasonable explanations to that. First of all, there is a lack of information in the sense that the subjects do not know if the other is rational or not. Also there could be a reputation effect in the game itself, which gives incentives to mimic. This happen because in a sequential game you obtain information of the other player in form of previous actions. If you have a proof that the other is not rational, maybe you should pass too because probably he will not be rational in the future.

PROPORTION OF OBSERVATIONS AT EACH TERMINAL NODE

	<i>N</i>	<i>f</i> ₁	<i>f</i> ₂	<i>f</i> ₃	<i>f</i> ₄	<i>f</i> ₅	<i>f</i> ₆	<i>f</i> ₇
Four Move	281	.071	.356	.370	.153	.049		
Six Move	281	.007	.064	.199	.384	.253	.078	.014

[Fig. 4. Empirical results in the modest version of Aumann's]

As we move to the end of the game, the probability of choosing “take” increase. When the game is repeated, the players end lightly earlier, but they played almost in the same way.

Aumann (1995) showed how the rationality of the players and common knowledge of this rationality is enough to imply the backward induction results in the centipede game. Later, Binmore (1996) and Aumann (1996) discussed how this is true in the sense of if the action “pass” can be used as a signal even if both are rational and know it.

Fey, McKelvey and Palfrey (1996) introduce a new version of the game for an experimental case, a constant-sum one. In this game, the sum of the payoffs in all nodes is the same.

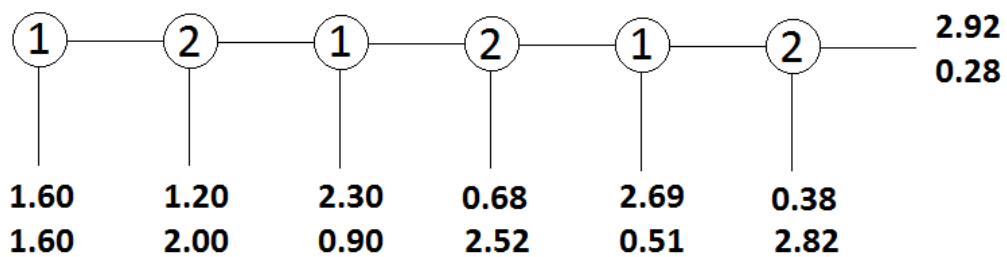

[Fig. 5. Constant sum centipede game, 6 nodes version]

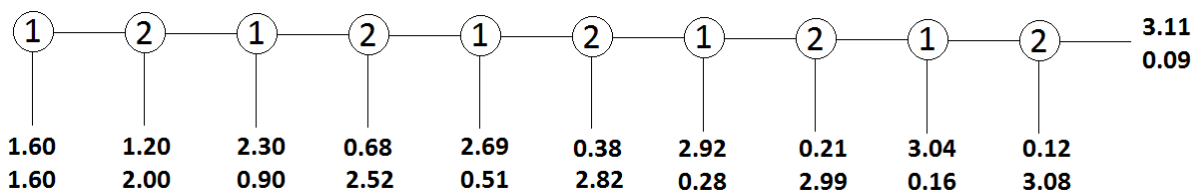

[Fig. 6. Constant sum centipede game, 10 nodes version]

At the beginning, the sum of 3.20\$ is split equally. Each following node, a quarter part of the little mound is passed to the bigger one. This game was designed to eliminate the altruistic explanation to the previous empirical results: there is no gain in efficiency or pareto-efficiency along the game.

Some empirical results were similar to the increase-sum ones. The probability of playing take grows as people move to later nodes. Playing the game repeatedly, people play the subgame perfect Nash equilibrium more often. The different results were that nearly the half of the cases played the equilibrium in the first time playing, and they finish in later nodes with lower probability.

The model that explained better these constant-sum results was the quantal responses equilibrium model. It is a model where people play in the common knowledge of rationality way, but it is possible to make mistakes with some probability.

Nagel and Tang (1998) presented this game:

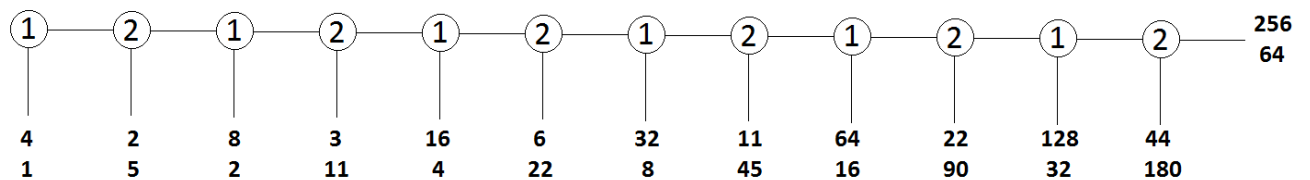

[Fig. 7. Nagel and Tang centipede game: extensive form]

It is an increasing 12-node centipede game. They presented the game in the normal form way. The strategies represented in columns and rows are the node in which the player wants to play “take” and stop the game.

1	2	Take in 2	Take in 4	Take in 6	Take in 8	Take in 10	Take in 12	Always pass
Take in 1	4	4	4	4	4	4	4	4
1	1	1	1	1	1	1	1	1
Take in 3	2	8	8	8	8	8	8	8
3	5	2	2	2	2	2	2	2
Take in 5	2	3	16	16	16	16	16	16
5	5	11	4	4	4	4	4	4
Take in 7	2	3	6	32	32	32	32	32
7	5	11	22	8	8	8	8	8
Take in 9	2	3	6	11	64	64	64	64
9	5	11	22	45	16	16	16	16
Take in 11	2	3	6	11	22	128	128	128
11	5	11	22	45	90	32	32	32
Always pass	2	3	6	11	22	44	256	256
pass	5	11	22	45	90	180	64	64

[Fig. 8. Nagel and Tang centipede game: normal form]

The game was tested empirically in this form. To make it close as possible as the extensive form, the subjects had only the feedback of the outcome they get. That means, they did not know the strategy chosen by the opponent when they stop the game before him.

They get similar results that McKelvey and Palfrey (1992). Most of the subjects stop in middle-late nodes (nodes 7, 8, 9, 10, in a game of 12). One interesting conclusion was in the repeated game: people react different depending on what they have done in the previous round. If they finished the game stopping before the opponent, they tend to pass more in the next one. The opposite if the opponent was who stopped first.

Nagel and Tang explained the results with the altruistic model, where 5% of the subjects are altruistic. The altruistics want to get the efficient node (always pass). The other subjects are utility maximizers, but they know there is a 5% of altruistics.

Rapoport (2003) designed a similar game, with the rules of a centipede game, but involving 3 players and a different end.

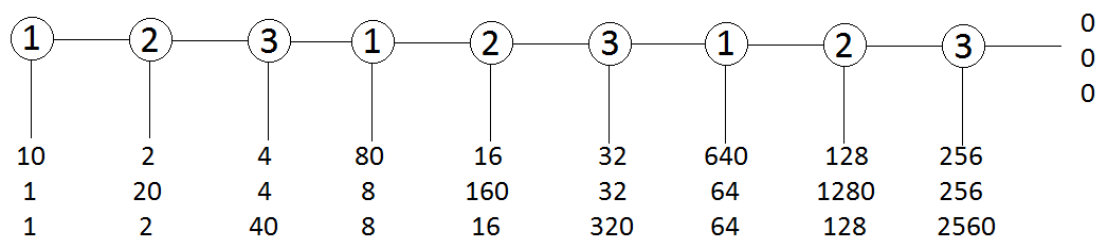

[Fig. 9. 3-players Rapoport game]

The subgame perfect Nash equilibrium was played 46% of the times, and when the game was repeated 60 times, the percentage increased to 75% in the last 5.

Palacios-Huerta and Volij (2009) experimented with chess players playing the centipede game. Chess players are known by their capacity of inductive reasoning. They can have in mind lots of possible future actions of the opponent when they make a movement. For the experiment, they used a modest version of Aumann's game without decimals:

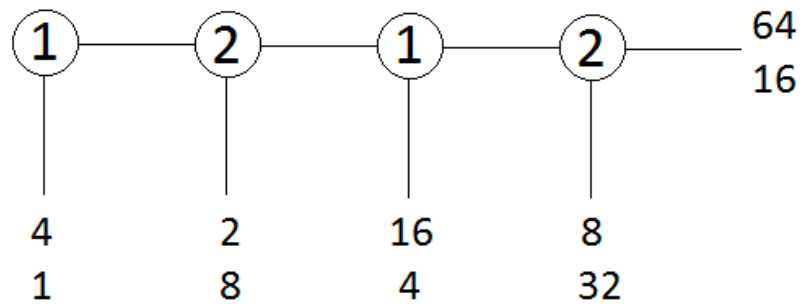

[Fig. 10. Modest version of Aumann's game without decimals, 4-node version]

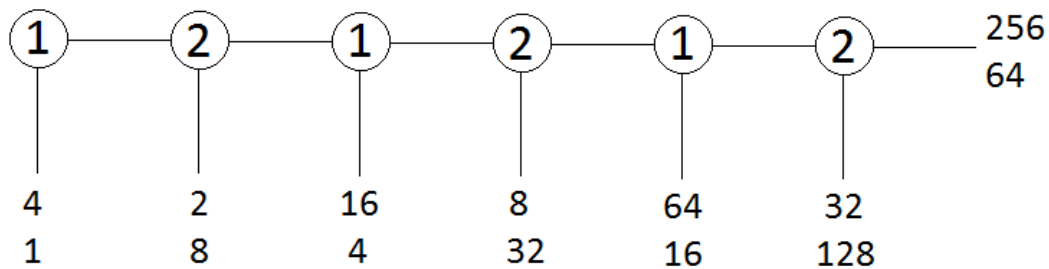

[Fig. 11. Modest version of Aumann's game without decimals, 6-node version]

The results supported the hypothesis that there are different levels of reasoning. When the chess players played against each other, the subgame perfect Nash equilibrium outcome was reached 69% of the times. If the player who started the game was a grandmaster, was reached a 100% of the times. From the fifth repetition, everybody played the equilibrium.

They also perform the experiment with students. As usual, just a 3% of the students played the equilibrium. But if they were playing against chess players (and they knew it), the percentage increased to a 30%, showing that this levels of reasoning were intuited by the players too. These results show that the (lack of) common knowledge of rationality may be one of the reasons behind the discrepancy between the theory and experimental results. This supports some kind of analysis of the game like level-k.

A level-k analysis of the game was made by Kawagoe & Takizawa (2010). They made an analysis highlighting the importance of determine which strategy should be the level 0 in this kind of games.

3 Centipede game definition

A finite sequential game with perfect information and 2 players with the form:

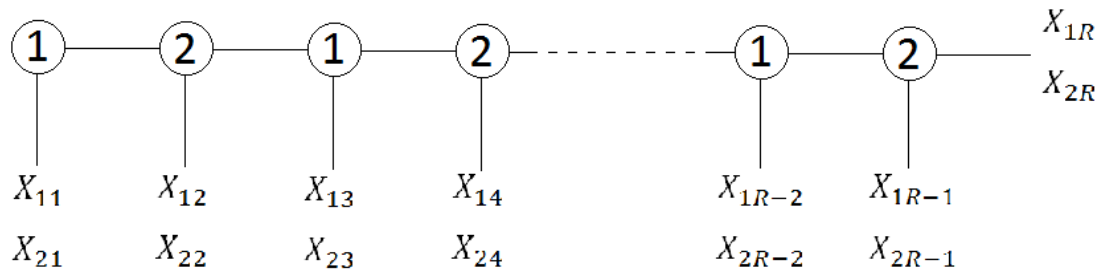

[Fig. 12. Structure of centipede game]

Where, given an arbitrary pair of payoffs X_{11} and X_{21} :

$$\text{in DN for player } i: \begin{cases} x_{ir} < x_{ir+2} \\ x_{jr} < x_{jr-1} \end{cases}$$

Sequential game implies, as mentioned earlier, that players take decisions sequentially, after they have observed what the other player has done. Perfect information means that all the players know the payoffs and structure of the game. More importantly, they always know in which node they are when playing. R refers to the number of nodes or rounds of the game, where r refers to the round.

The player identifiers are i and j which can be in position of player 1 and 2 or vice versa. X_{ir} represents the payoff of the player i in the round r . “In DN for player i ” means that this condition occurs in the decision node in which player i moves, being j the opponent, and being i playing in the role of any player, 1 or 2.

In each round r , they share a sum S_r :

$$S_r = x_{ir} + x_{jr}$$

Condition 1 ($x_{ir} < x_{ir+2}$) is what gives the incentives to move forward the game. Player i 's payoff is always higher if he plays “take” in a later decision node. Condition 2 ($x_{jr} < x_{jr-1}$) is what gives the incentives to be the one who stops the

game. If the opponent played “take”, j would regret have passed in the previous round, because his payoff there would have been higher.

4 Implications

If Conditions 1 and 2 hold then:

(a) implication 4.1

$$\text{in DN for player } i: x_{ir} > x_{ir-1}$$

Proof:

The payoff at the decision node is higher than at the previous one. This is easily proven with a transitive relation between the two conditions of the definition:

$$\text{In DN for player } i: \begin{cases} x_{ir-2} < x_{ir} \\ x_{ir-1} < x_{ir-2} \end{cases} \Rightarrow x_{ir} > x_{ir-2} > x_{ir-1} \Rightarrow x_{ir} > x_{ir-1}$$

(b) implication 4.2

$$\text{in DN for player } i: S_r < x_{ir+2} + x_{jr-1}$$

Proof:

By definition:

$$S_r = x_{ir} + x_{jr}$$

$$\text{In DN for } i: \begin{cases} x_{ir} < x_{ir+2} \\ x_{jr} < x_{jr-1} \end{cases}$$

In consequence:

$$S_r = x_{ir} + x_{jr} < x_{ir+2} + x_{jr-1} \Rightarrow S_r < x_{ir+2} + x_{jr-1}$$

The sum of the payoffs of both players in one round is lower than the payoff incentive to keep playing of the decider player and the payoff that the opponent has sacrificed in the previous round.

(c) Implication 4.3

The limitation of S_r does not imply any specific progression of the Sum along the game.

Proof:

You can always add a new end node with any Sum of your preference. In the end node, x_{ir+2} does not exist yet. In consequence, if later you continue writing the game and reach X_{ir+2} , you can make this payoff as high as you want to compensate x_{jr-1} .

So, the progression of the Sum along the game is not restricted. We can classify the centipede game in types, depending on this progression.

Increasing Sum:

$$S_r > S_{r-1}$$

It is the most common centipede type observed in the literature. Depending on the speed of the progression it can be also divided in subcategories:

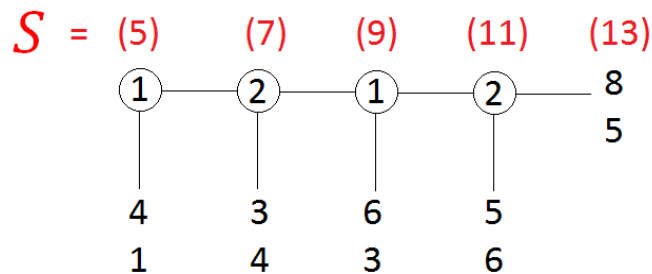

[Fig. 13. Example of linear increasing sum centipede game]

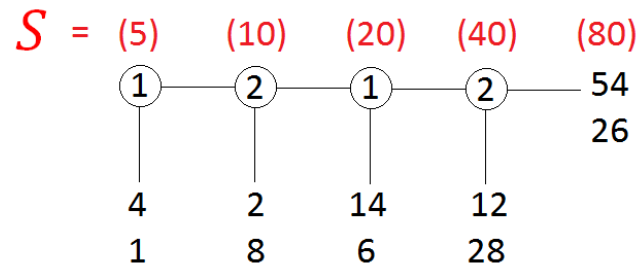

[Fig. 14. Example of exponential increasing sum centipede game]

Constant Sum:

$$S_r = S_{r-1}$$

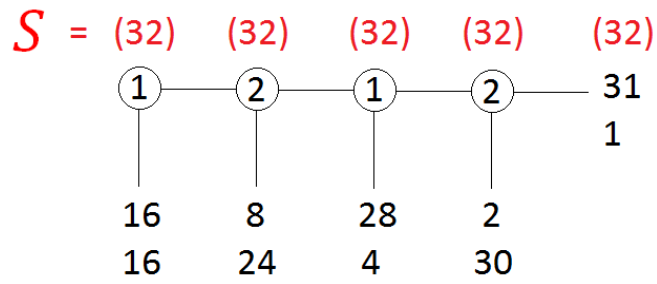

[Fig. 15. Example of constant sum centipede game]

Decreasing Sum:

$$S_r < S_{r-1}$$

It can also be subdivided depending on the speed of the progression:

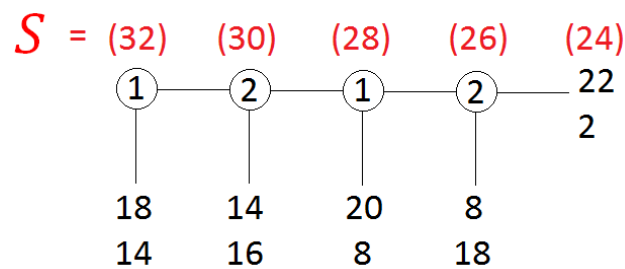

[Fig. 16. Example of linear decreasing sum centipede game]

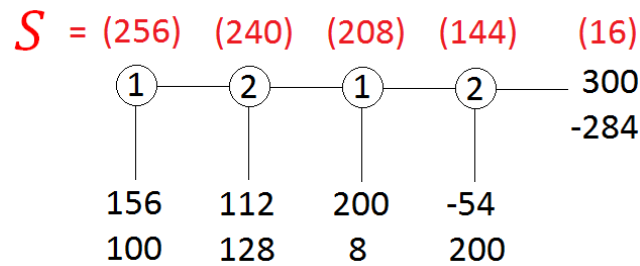

[Fig. 17. Example of exponential decreasing sum centipede game]

Variable sum:

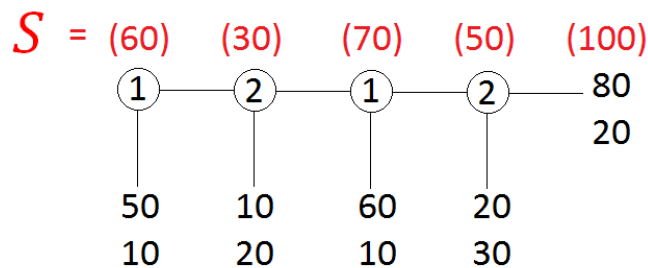

[Fig. 18. Example of exponential decreasing sum centipede game]

Note that off among all these possibilities only the increasing and constant have been treated in the literature.

5 Predictions

5.1 Subgame perfect Nash equilibrium

This is the standard equilibrium solution in sequential games. The Nash equilibrium is the set of strategies that satisfy that each payer is best-responding to the other. The subgame perfect means that this condition must be satisfied not only in the general game, but also in all the subgames of it. The reason of this is to avoid incredible threats. The subgame perfect Nash equilibrium in the centipede game is to play “take” in every node. Let me show an example with 4 nodes:

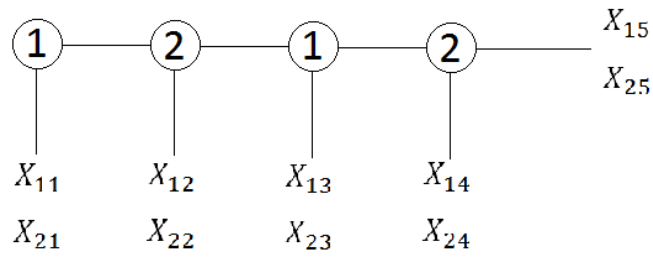

[Fig. 19. 4-node centipede game]

Remembering the conditions:

$$\text{in DN for player } i: \begin{cases} x_{ir} < x_{ir+2} \\ x_{jr} < x_{jr-1} \end{cases}$$

We obtain the relation between the payoffs:

$$\begin{array}{l} \text{Player 1} \\ \text{Player 2} \end{array} \left\{ \begin{array}{l} x_{12} \quad x_{14} \\ \wedge \quad \wedge \\ x_{11} < x_{13} < x_{15} \\ \\ \\ x_{23} \quad x_{25} \\ \wedge \quad \wedge \\ x_{21} < x_{22} < x_{24} \end{array} \right.$$

[Fig. 20. Relations between the payoffs of a 4-node centipede game]

We can solve the game by backward induction:

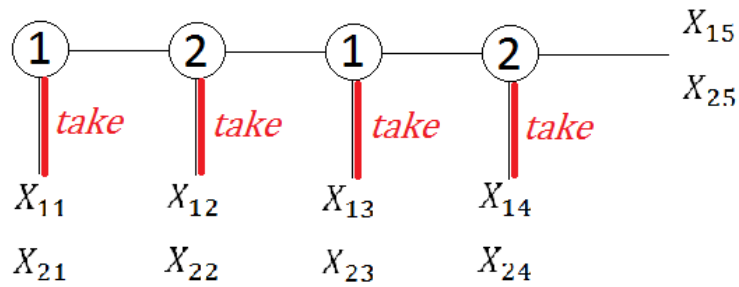

[Fig. 21. Backward induction solving]

In the last node, the second player must choose between obtain x_{24} or x_{25} . Since the player is utility maximizer and $x_{24} > x_{25}$, he will play “take” in this node. In the previous one, player 1 has to choose to take and have x_{13} or pass. There is common knowledge of rationality, so he knows what player 2 would do if he pass: play take. Then he would obtain x_{14} . Since $x_{13} > x_{14}$, player 1 will also “take”. We can apply this logic to all the nodes and get the subgame perfect Nash equilibrium, where the players obtain x_{11} and x_{21} respectively.

We can also reach the same conclusion solving the game in normal form.

	Player 2			
	Take in node 2 Take in node 4	Take in node 2 Pass in node 4	Pass in node 2 Take in node 4	Pass in node 2 Pass in node 4
Player 1				
Take in node 1 Take in node 3	x_{11} x_{21}	x_{11} x_{21}	x_{11} x_{21}	x_{11} x_{21}
Take in node 1 Pass in node 3	x_{11} ∨ x_{21}	x_{11} ∨ x_{21}	x_{11} ∧ x_{21}	x_{11} ∧ x_{21}
Pass in node 1 Take in node 3	x_{12} x_{22}	x_{12} x_{22}	x_{13} ∨ x_{23}	x_{13} ∧ x_{23}
Pass in node 1 Pass in node 3	x_{12} x_{22}	x_{12} x_{22}	x_{14} x_{24}	x_{15} x_{25}

[Fig. 22. Nash equilibriums in normal form]

Each column and row represents the different possible strategies of the players. The payoffs are related to each other by the relation signs to make easier spot the best response strategies. In circles are marked the best response given the strategy played by the opponent. For example, if player 1 plays “Pass in node 1, Pass in node 3”, the best response of the player 2 is to play “Pass in node 2, Take in node 4”, because playing this strategy he obtain x_{24} , which is the higher payoff possible.

We can see that there are 4 spots where both players are playing best response strategies at the same time. These are pure strategies Nash equilibriums. Of this four, those strategies that imply to play pass in any moment do not satisfy the subgame perfect condition. Those that include “pass in node 4” are violating the subgame:

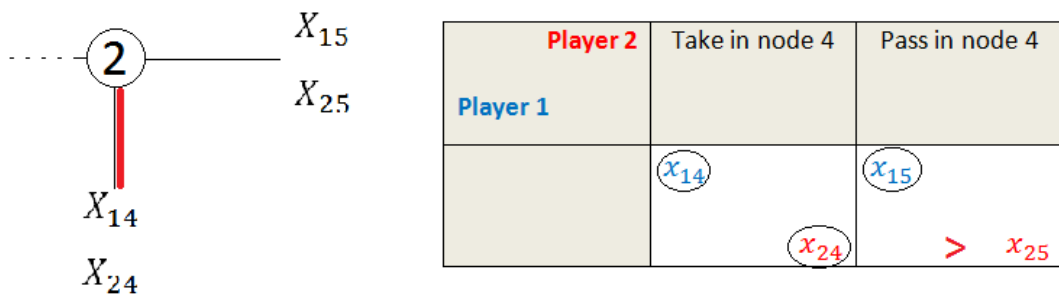

[Fig. 23. Round 4 subgame]

Because it is not credible that player 2 will behave passing if he reaches this node. Those strategies that include player 1 passing in node 3 are also not credible:

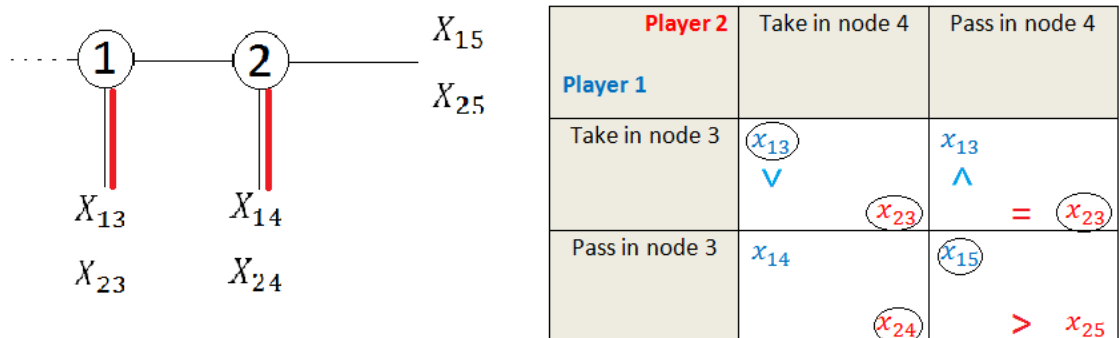

[Fig. 24. Round 3 subgame]

So, the only subgame perfect equilibrium is both players playing take in every round, with the outcome $[x_{11}, x_{21}]$. This is the result no matter how many nodes the centipede game has, and what type is it.

In fact, there is no need of the SPE concept to reach this result. Aumann (1998) proved that common knowledge of rationality, that is, if it is commonly known that the players will choose rationally at every decision node that are actually reached, then the backward induction outcome results.

5.2 Welfare maximization

In sharp contrast with the standard selfish preferences assumptions, individuals might care about maximizing social welfare. Assume for simplicity that individuals weight in the same way their payoff and the other player's payoffs, such that they are maximizing the sum of payoffs (Charness and Rabin, 1999). In our game, this means that players will care about the sum, S_r , independent of how this sum will be split.

This prediction will critically depend on the pattern along the game of the sum of the payoffs (Implication 4.3). In an increasing sum game, by definition, the biggest sum is located in the final round of the game. Then, the welfare maximization result is the last outcome where everybody has decided to "pass". In the decreasing sum centipede games, the sum will become lower with the rounds: the welfare maximization will predict to stop in the very first round, coinciding with the subgame perfect equilibrium. The same logic is applied to the constant sum games, where every sum is equal and in consequence every round is welfare maximizing, such that efficiency will predict any outcome is possible. Finally, in a variable sum centipede game, the prediction will be the round where the sum is biggest, which will be unique but it could potentially be in any decision node.

5.3 Pareto efficiency

Pareto optimality is a measure of efficiency. An outcome is Pareto optimal if it is not possible to find another outcome where at least one player is better off, and the rest of the players are not worse off.

Again, Pareto optimality predictions will depend on the type of game, based on the increasing/constant/decreasing/variable pattern of the sum.

First, for any types of the payoff pattern, we can say for sure that the two last rounds are Pareto efficient. This is because, by definition, the payoffs of the last two rounds have the maximum payoff for one player. In consequence, it is impossible to get better payoffs for both players since one is the best for one of them.

Second, for increasing sum games, we can say nothing about the other rounds. It is possible that no other round is Pareto efficient, or just some, or even all of them.

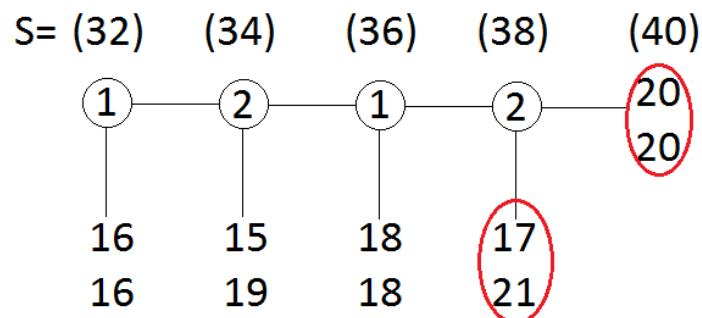

[Fig. 25. Increasing sum centipede game with only two Pareto efficient rounds]

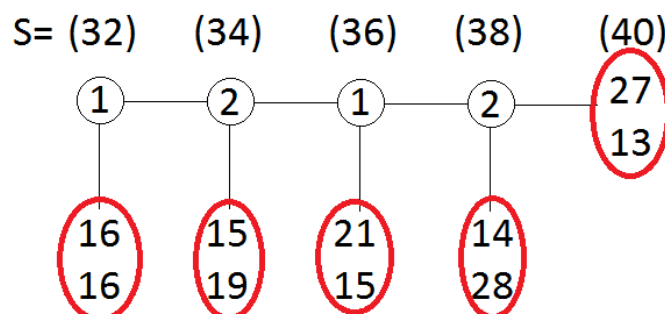

[Fig. 26. Increasing sum centipede game with all rounds Pareto efficient]

If you want to make every round Pareto efficient, you just have to make sure that the payoff of the non-decider player is the lower payoff comparing it with the previous ones. By definition, the payoff of the decider player is bigger than the previous ones. These two things will make all rounds Pareto efficient. It will be impossible to have any Pareto improvement because when you have a round with a better payoff for one, is worst for the other.

Third, with this idea in mind is easy to understand why all rounds are Pareto efficient in constant and decreasing sum games. In a constant sum game, the sum does not change. In consequence, when we give a higher payoff to the decider player is at the expense of lowering the payoff of the opponent. The same logic but even stronger is applied to the decreasing sum games.

Finally, in the variable sum ones, it depends on the concrete sums that we are using.

5.4 Maximin

Maximin is a decision rule that maximizes the minimum possible gain at the worst case. The result is the same as the Nash equilibrium: “take” in every node. This results in ending the game in the first round, independent of the pattern of the sum of the payoffs along the sequential nodes.

It is easy to see this result in the extensive form. We can use the example of the 6-node centipede game, represented in Figure 27.

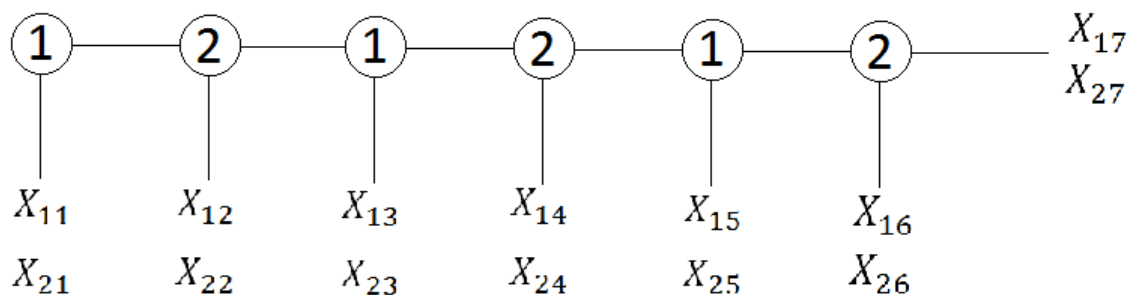

[Fig. 27. 6-node centipede game]

$$\begin{array}{l}
 \text{Player 1} \left\{ \begin{array}{l} X_{12} \quad X_{14} \quad X_{16} \\ \wedge \quad \wedge \quad \wedge \\ X_{11} < X_{13} < X_{15} < X_{27} \end{array} \right. \\
 \\
 \text{Player 2} \left\{ \begin{array}{l} \quad \quad X_{23} \quad X_{25} \quad X_{27} \\ \quad \quad \wedge \quad \wedge \quad \wedge \\ X_{21} < X_{22} < X_{24} < X_{26} \end{array} \right.
 \end{array}$$

[Fig. 28. Relations between the payoffs of a 6-node centipede game]

Having in mind the payoffs relations of the Figure 28:

Player 1

Player 2

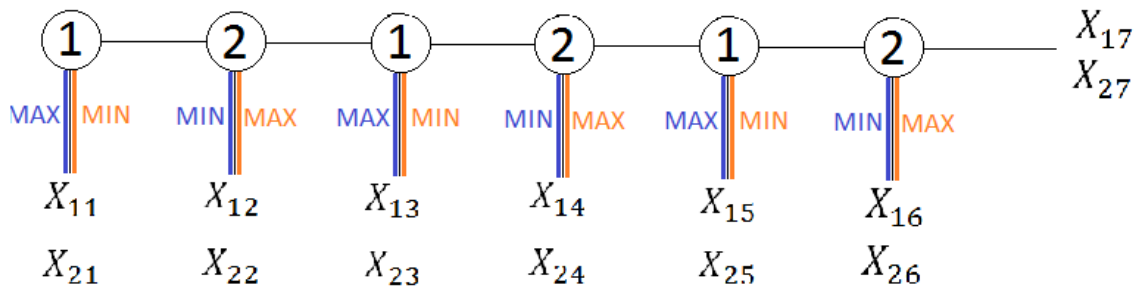

[Fig. 29. Maximin prediction of the 6-node centipede game in extensive form]

Being the player 1: In the last node, the worst for him that the opponent can choose is minimize his payoffs. That happen when he plays “take”, and player 1 would obtain x_{16} . In the previous node, player 1 maximize his payoffs, guessing that his opponent would play “take” as we said. That result in play take, because x_{15} is higher than x_{16} . Then, the worst that the opponent can do in the second node is “take” because x_{14} is lower than x_{15} . If we continue this process, in the first node the player 1 will maximize his own payoff playing “take”. The same logic can be applied to player 2, with the same result of playing “take” in every node.

We can reach the same result in the normal form:

Player 2 Player 1	Take in node 2	Take in node 4	Take in node 6	Always pass	MÍN
Take in node 1	$x_{11} =$ x_{21}	$x_{11} =$ x_{21}	$x_{11} =$ x_{21}	x_{11} x_{21}	x_{11}
Take in node 3	$x_{12} <$ x_{22} \wedge	$x_{13} =$ x_{23} \neg	$x_{13} =$ x_{23} \neg	x_{13} x_{23} \neg	x_{12}
Take in node 5	$x_{12} ?$ x_{22} \parallel	$x_{14} <$ x_{24} \wedge	$x_{15} =$ x_{25} \neg	x_{15} x_{25} \neg	x_{12}/x_{14}
Always pass	$x_{12} ?$ x_{22} \parallel	$x_{14} ?$ x_{24} \parallel	$x_{16} <$ x_{26} \wedge	x_{17} x_{27} \neg	$x_{12}/x_{14}/x_{16}$
MÍN	x_{21}	x_{21}/x_{23}	$x_{21}/x_{23}/x_{25}$	$x_{21}/x_{23}/x_{25}/x_{27}$	<div style="border: 2px solid black; padding: 5px; display: inline-block;"> MAXIMÍN x_{11} MAXIMÍN x_{21} </div>

[Fig. 30. Maximin prediction of the 6-node centipede game in normal form]

In the rows and columns are the set of strategies of player 1 and 2. “Take in node 3” means all the strategies that content taking in the third node. The payoffs are related to each other by the relation signs to be easier to spot the minimums. The question mark means that we do not know the relation between those two payoffs. The column and row “MIN” shows the minimum payoff that one player could get, given that set of strategies.

To solve maximin in normal form, we need to detect the minimum payoff of each set of strategies. Then, spot the maximum payoff of all those minimum payoffs. Doing this, we maximize the minimum payoff, in case that the opponent plays in the worst possible way.

The “MIN” column shows us the minimum payoffs for each player 1 set of strategies. In the last two set of strategies there are more than one payoff. That is because we do not know which of these is lower, it can be anyone. So, ¿how is possible to know that x_{11} is the highest?. Well, let us look for some cases.

In case that $x_{12} > x_{14} > x_{16}$, the minimum in “Take in node 5” is x_{14} and the minimum in “Always pass” is x_{16} . The bigger of the three is x_{12} and since $x_{11} > x_{12}$, the maximin is x_{11} .

In case that $x_{16} > x_{14} > x_{12}$, the minimum in “Take in node 5” and “Always pass” is x_{12} . Since $x_{11} > x_{12}$, the maximin is x_{11} .

It is always the same for every combination, and no matter how many nodes are. The same logic applies for the player 2.

6 Conclusion

In this paper we have first reviewed the literature, both theoretical and experimental, of the centipede game. Second, we have defined the game, proposing a characterization of the payoff structure that defines the centipede game. Despite the game being an object of study in several papers, only a limited number of possible versions of the centipede game have been studied, in particular, those with increasing and constant sums. Third, and more importantly, we have identified not only subgame perfect equilibrium predictions but also other alternative solutions, such as welfare maximizing equilibrium predictions, which crucially depend on the evolution of the sum along the sequential games. We now finish this critical review pointing out how different types of centipede games, in particular increasing/constant/decreasing/variable sum centipede games, could be potentially used to identify alternative hypothesis about the non-equilibrium behavior in the centipede game.

As an example, we could propose the following three alternative centipede games:

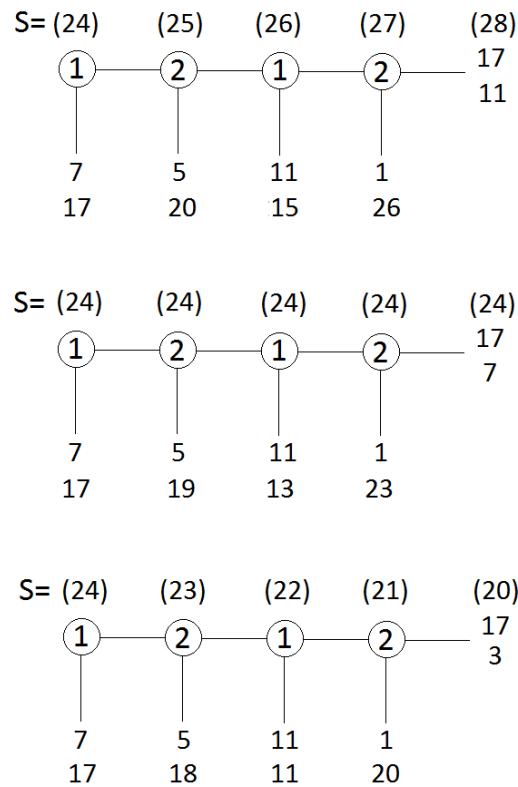

[Fig. 31. Different types of centipede game with same payoffs for player 1]

Giving equal payoffs to the player 1, we can modify other aspects of the game in order to see the change in his behavior. In the case of figure 31, just the payoffs of the opponent and the sum structure of the game are changed. These three centipede games offer the opportunity to sharply distinguish between subgame perfect equilibrium and welfare maximizing (efficiency) predictions. The former does not depend on whether the sum of the payoffs is increasing/constant/decreasing, while the latter does.

Another example: Kawagoe and Takizawa (2010) made a level-k analysis of the centipede game. Level-k model is a non-equilibrium theory of initial responses of players that takes into account other players' strategic thinking. It has been applied mostly to normal-form games. The lowest level is level-0, representing people who do not reason at all, and play random. Level-1 is best-response to level-0, level-2 is best response to level-1, and so on. Kawagoe and Takizawa (2010) point out that the key in this analysis is to know what a level-0 would do in a sequential game. One possibility is randomizing in the sequential-form of the game, having 50% of chances of stop or take in each node. This gives much more possibilities to stop in the first node (50%) than in

the last ones (6,25% in the 4^o node). The other possibility is randomizing in the normal-form, giving the same probability to each set of strategies containing stop in each node. That means, deciding in which node he is going to stop, giving each one the same probability. This way, the chances of stopping in each decision node are the same for all nodes.

Kawagoe and Takizawa (2010) tried to explain the non-equilibrium behavior applying level-k model. Even they admitted that the key of the analysis is knowing what a level-0 would do, they compare the two possibilities in the traditional games of the literature (increasing and constant types). In those games, the analysis of the two possible level-0 gives similar results: The most common behavior of players in experiments have been level-1 and level-2 predictions. Those two in increasing and constant games are very close to each other (or even the same) in alternative definitions of level-0. In consequence, it is hard to know if the observation matches with one or the other.

If the tools of our analysis are used, a specific centipede game can be designed to solve this problem.

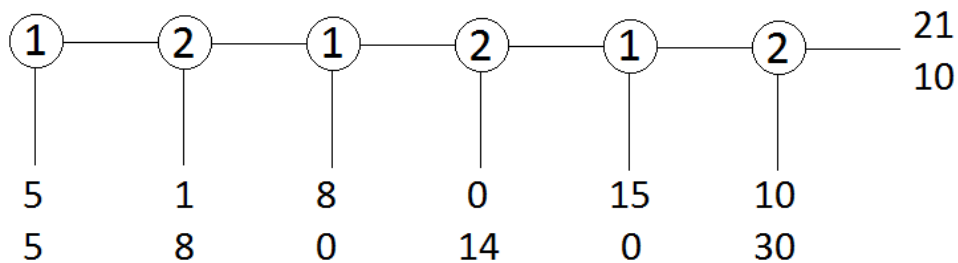

[Fig. 32. Centipede game design to test which is better level-0]

Sequential-form L0

Normal-form L0

Player 2	Take in node 2	Take in node 4	Take in node 6	Always pass
Player 1	L1 L2	L2	L1 L2 L2	L2
Take in node 1 L1 L2	5 5	5 5	5 5	5 5
Take in node 3	1 8	8 0	8 0	8 0
Take in node 5 L2	1 8	0 14	15 0	0 0
Always pass L1	1 8	0 14	10 30	21 10

[Fig. 33. Centipede game design to test which is better level-0 in normal form]

In this variable sum game, the predictions of the level-k analysis are different. For player 1, the different L1 are in opposite sides of the game. To figure out which level-0 is better, we could just test it with an experiment.

These two examples show that there is room for further exploration of the centipede game in order to identify the non-equilibrium play behind the centipede game. In summary, the different possibilities of the payoff-structure could be a powerful tool to design specific centipede games in the laboratory to discriminate between alternative explanations. This line of research should be pursued in future work.

Reference List

- Rosenthal, R. W. (1981). "Games of perfect information, predatory pricing and the chain-store paradox." *Journal of Economic Theory*, 25, 92-100.
- Megiddo, N. (1986). "Remarks on bounded rationality." Technical report, IBM Research Report RJ 54310, Computer Science
- Binmore, K. (1987). "Modeling Rational Players". *Economics and Philosophy*, 3, pp 179-214. doi:10.1017/S0266267100002893.
- Aumann, R. J. (1992). "Irrationality in game theory." *Economic analysis of markets and games: Essays in honor of Frank Hahn*, 214-27.
- McKelvey, R. D., & Palfrey, T. R. (1992). "An experimental study of the centipede game." *Econometrica: Journal of the Econometric Society*, 803-836.
- Aumann, R. J. (1995). "On the centipede game." *Games and Economic Behavior*, 23(1), 97-105.
- Binmore, K. (1996). "A note on backward induction." *Games and Economic Behavior*, 17(1), 135-137.
- Aumann, R. J. (1996). "Reply to Binmore." *Games and Economic Behavior*, 17(1), 138-146.
- Fey, M., McKelvey, R. D., & Palfrey, T. R. (1996). "An experimental study of constant-sum centipede games." *International Journal of Game Theory*, 25(3), 269-287.

Nagel, R., & Tang, F. F. (1998). "Experimental results on the centipede game in normal form: an investigation on learning." *Journal of Mathematical Psychology*, 42(2), 356-384.

Charness, G., & Rabin, M. (2002). "Understanding social preferences with simple tests." *Quarterly journal of Economics*, 817-869.

Rapoport, A., Stein, W. E., Parco, J. E., & Nicholas, T. E. (2003). "Equilibrium play and adaptive learning in a three-person centipede game." *Games and Economic Behavior*, 43(2), 239-265.

Palacios-Huerta, I., & Volij, O. (2009). "Field centipedes." *The American Economic Review*, 99(4), 1619-1635.

Kawagoe, T., & Takizawa, H. (2012). Level-k analysis of experimental centipede games. *Journal Of Economic Behavior & Organization*, 82(2), 548-566.